



Parts Manual

Mfg. No: 2691651-00
360 23.00 HP B&S Professional Series
CARB 42" Fabricated Mower Deck



1692125 - Cart, Dump (10 Cu. Ft.)
1696690 - Headlight Kit.
1696692-00 - Cargo Bed Kit.
1696687YP - Extended Engine Protect.
1687860 - Mesh Seat Kit.
1687855YP - Rhino Grip.
1687856YP - Rhino Grip, Ratcheting.
1687810YP - Arm Rest Kit, 15" Plastic Seat.
1696673-01 - Twin Grass Catcher & Front Weight.
1696669-01 - Bagging Boot, Blade & Baffle, 42".
1696915-01 - Grass Mulcher Kit, 42" Fabricated Mower Deck.
1696673A-00 - Twin Grass Catcher & Front Weight.
1696669A-00 - Bagging Boot, Blade & Baffle, 42".
1697373A-00 - Bagging Boot, Blade & Baffle, 42".
1697408A-00 - Kit, ZT Catcher, Twin, CS.

Not For
Reproduction

Model Components	Page
42" Mower Deck - Clutch & Support Group.....	4
42" Mower Deck - Housing, Arbor & Blade Group.....	6
Body & Fuel Tank Group.....	8
Controls Group.....	10
Decals Group.....	12
Electrical Group.....	14
Engine Group.....	16
EVAP Group.....	18
Frame Group.....	20
Lift Group.....	22
Parking Brake Group.....	24
Seat Group.....	26
Transmission Group.....	28
Wheel & Tire Group.....	30
Torque Specification Chart.....	32

Not For
Reproduction

42" Mower Deck - Clutch & Support Group

Note: Unless noted otherwise, use the standard torque specifications

Mfg. No: 2691651-00

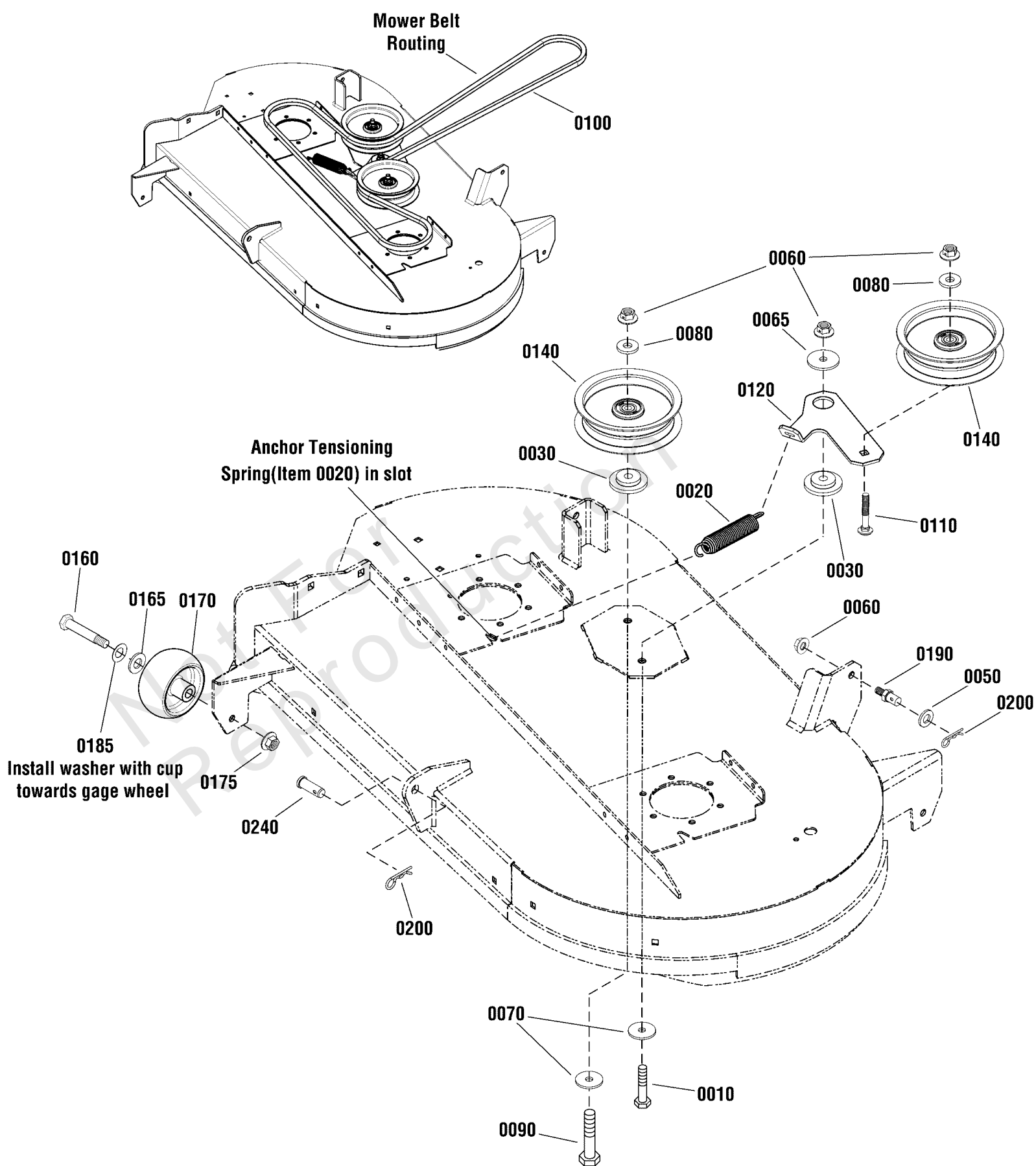

42" Mower Deck - Clutch & Support Group

REF NO	PART NO	QTY	DESCRIPTION
0010	703406	1	CAPSCREW,3/8-16X1.5
0020	1715772SM	1	SPRING, Extension
0030	706128	2	SPACER, IDLER
0050	703853	2	WASHER, 0.516IDX1OD
0060	703158	5	NUT, Hex Flange, 3/8-16
0065	5025305SM	1	WASHER, .41 X 1.75 X
0070	703591	2	WASHER, .406X1.5X.12
0080	703878	2	WASHER, FLAT
0090	703133	1	HHCS,3/8-16X2.750
0100	1758101YP	1	BELT, 113.0 Effective Length
0110	7900009SM	1	RHSSNB, 3/8-16 X 2-1/
0120	1758789AYP	1	ARM, Idler
0140	7034422SM	2	(C) PULLEY, FLAT IDLE
0160	2108765SM	2	BOLT-WHEEL 3/8-16X2.7
0165	703853	2	WASHER, 0.516IDX1OD
0170	1714760SM	2	GAUGE WHEEL
0175	703158	2	NUT, Hex Flange, 3/8-16
0185	0020X3MA	2	WASHER,SPRING .52X.99
0190	704054	2	PIN, 3/8-16
0200	703300	3	PIN, 3/32 X 1.6
0240	5025479YP	1	CLEVIS PIN, 1/2 X 1.3

42" Mower Deck - Housing, Arbor & Blade Group

Note: Unless noted otherwise, use the standard torque specifications

Mfg. No: 2691651-00

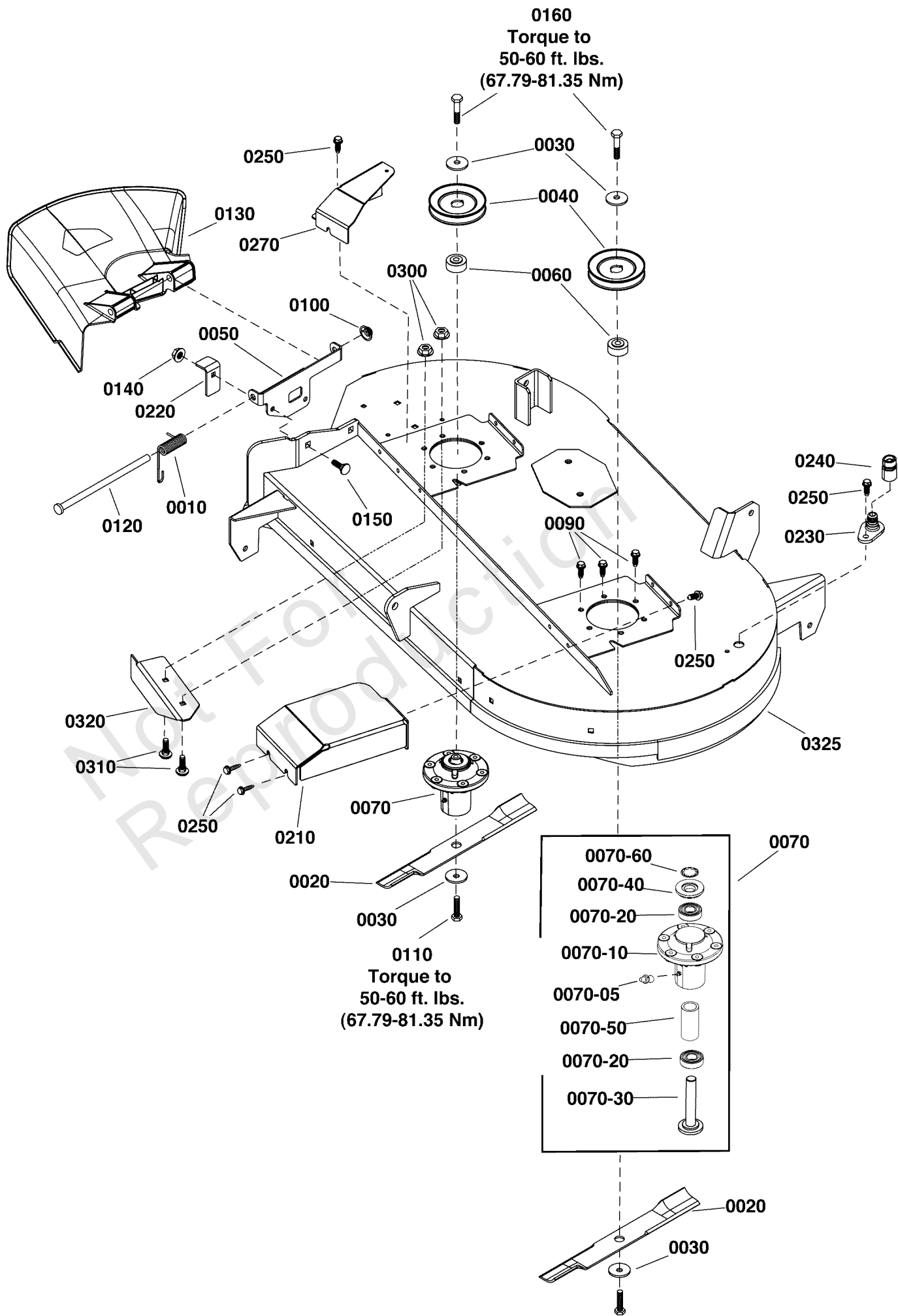

42" Mower Deck - Housing, Arbor & Blade Group

REF NO	PART NO	QTY	DESCRIPTION
0010	7035813SM	1	SPRING, TORSION, SIDE
0020	1758878BMYP	2	BLADE, 21.31" Long
0030	1656916SM	4	WASHER, SPRING 0.475I
0040	1737835YP	2	PULLEY, 4.50
0050	1758982AYP	1	BRACKET, DEFLECTOR
0060	1737457YP	2	SPACER, Pulley
0070	84003173	2	ARBOR ASSEMBLY
0070-05	1704314SM	1	LUBE FITTING, .250 DR
0070-10	84003653	1	HOUSING ASSEMBLY
0070-20	1735399YP	2	BEARING, Ball, 20mm
0070-30	84003170	1	SHAFT, SPINDLE
0070-40	84003166	1	COVER, ARBOR
0070-50	84003167	1	SPACER, BEARING
0070-60	1960766YP	1	RING, SELF LOCKING
0090	704146	12	SCREW, HEX, 5/16-18X1
0100	703179	1	PUSHNUT, CAP TYPE
0110	1920676SM	2	CAPSCREW, Hex Head, 7/16-14 X 1
0120	7104640YP	1	ROD, Deflector
0130	7104733YP	1	CHUTE, SIDE DISCHARGE
0140	703793	2	LOCKNUT
0150	703815	2	BOLT, RD SQ 3/8-16X1
0160	1921212SM	2	CAPSCREW, Hex Head, 7/16-14 X 1 1/2
0210	1758992BMYP	1	COVER, Pulley, LH
0220	1758593BMYP	1	PROP, DEFLECTOR
0230	1756247YP	1	ADAPTER, Washout Port
0240	1756246YP	1	CONNECTOR, Washout Port
0250	1664847CAYP	7	SCREW, Hex Washer Head, Taptite, 5/16-18 x 3/4
0270	1759616AYP	1	COVER, Pulley, RH
0300	703115	2	NUT
0310	703185	2	BOLT, Round Head, Short Square Neck
0320	1758581BMYP	1	BAFFLE, Pinchoff
0325	1687859YP	1	KIT, Mower Deck w/Decals, 42"

Body & Fuel Tank Group

REF NO	PART NO	QTY	DESCRIPTION
0010	84008779	1	FENDER, Right
0020	1759369YP	1	ROD, Support
0030	703953	1	SCREW, 1/4-20X5/8
0040	1758202YP	1	FUEL TANK ASSEMBLY, No Fuel Gauge -(Includes item Nos. 0040-10 thru 0040-70)
0040-10	-----	1	TANK, Fuel -(Order item 0040)
0040-20	-----	1	NECK, Fuel Filter -(Order item 0040)
0040-30	1758314YP	1	CAP-FUEL TANK
0040-40	799624	1	GROMMET
0040-50	770046	1	VENT, Remote
0040-60	1758927YP	1	TUBE-PICK UP
0040-70	1726400SM	1	BUSHING
0045	1758919YP	1	FUEL TANK ASSEMBLY. W / Fuel Gauge -(Includes item Nos. 0045-10 thru 0045-90)
0045-10	-----	1	TANK, Fuel -(Order item 0045)
0045-20	-----	1	NECK, Fuel Filter -(Order item 0045)
0045-30	1758314YP	1	CAP-FUEL TANK
0045-40	799624	1	GROMMET
0045-50	770046	1	VENT, Remote
0045-60	1758927YP	1	TUBE-PICK UP
0045-70	1726400SM	1	BUSHING
0045-80	1758928YP	1	GAUGE-FUEL
0045-90	84004692	1	GROMMET
0050	197546GS	5	MOUNT-VIBRATION
0060	1758076YP	1	FENDER-LEFT
0070	1758239AYP	2	SUPPORT-FENDER
0080	84002196	1	BRACKET
0090	703228	18	SCREW, 5/16-18 X .75
0100	5025394SM	2	NUT, 3/8-16 HEX NYLOCK
0110	704038	2	SCREW
0120	1960044SM	4	WASHER-0.312(0.33IDX1
0130	1759140AYP	1	STRAP-FUEL TANK
0140	1760244YP	2	SUPPORT, Fuel Tank
0150	703054	2	SCREW, 1/4-20X0.625



Controls Group

REF NO	PART NO	QTY	DESCRIPTION
0010	1758372YP	2	HANDLE, CONTROL
0020	703115	4	NUT
0030	703483	4	BOLT,5/16-18X1.000,RO
0040	1757965YP	2	ARM, UPPER CONTROL
0050	707624	2	BOLT,SHLDR,5/16-18
0060	1757964YP	2	ARM, LOWER CONTROL
0070	2176440SM	4	BUSHING-0.765IDX
0080	703949	10	SCREW, 5/16-18.625
0090	1758087AYP	2	PIVOT, Inner Control
0100	5022308SM	2	BODY CLIP, 5/16-18 X
0110	1758373YP	2	KNOB, 5/16-18 X 2.5
0120	1650347SM	2	SPRING-COMP 0.50 IDX
0130	5025211SM	4	PIN, HAIR, .0585" X 1
0140	1758463YP	2	ROD, DAMPNER MNT
0150	84001625	2	DAMPENER
0160	1759182YP	2	LATCH, CONTROL ARM
0170	703101	4	BOLT,1/4-20X.75
0180	703463	4	NUT, GR5,1/4-20
0190	707625	2	WSHR, 3 WAVE, .750
0200	703902	2	NUT, HEX, 5/16-18

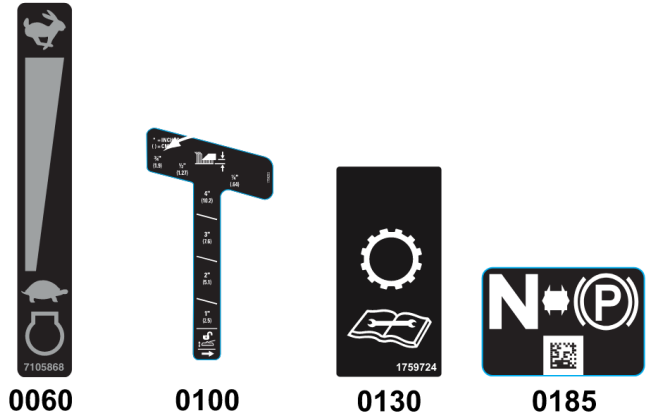
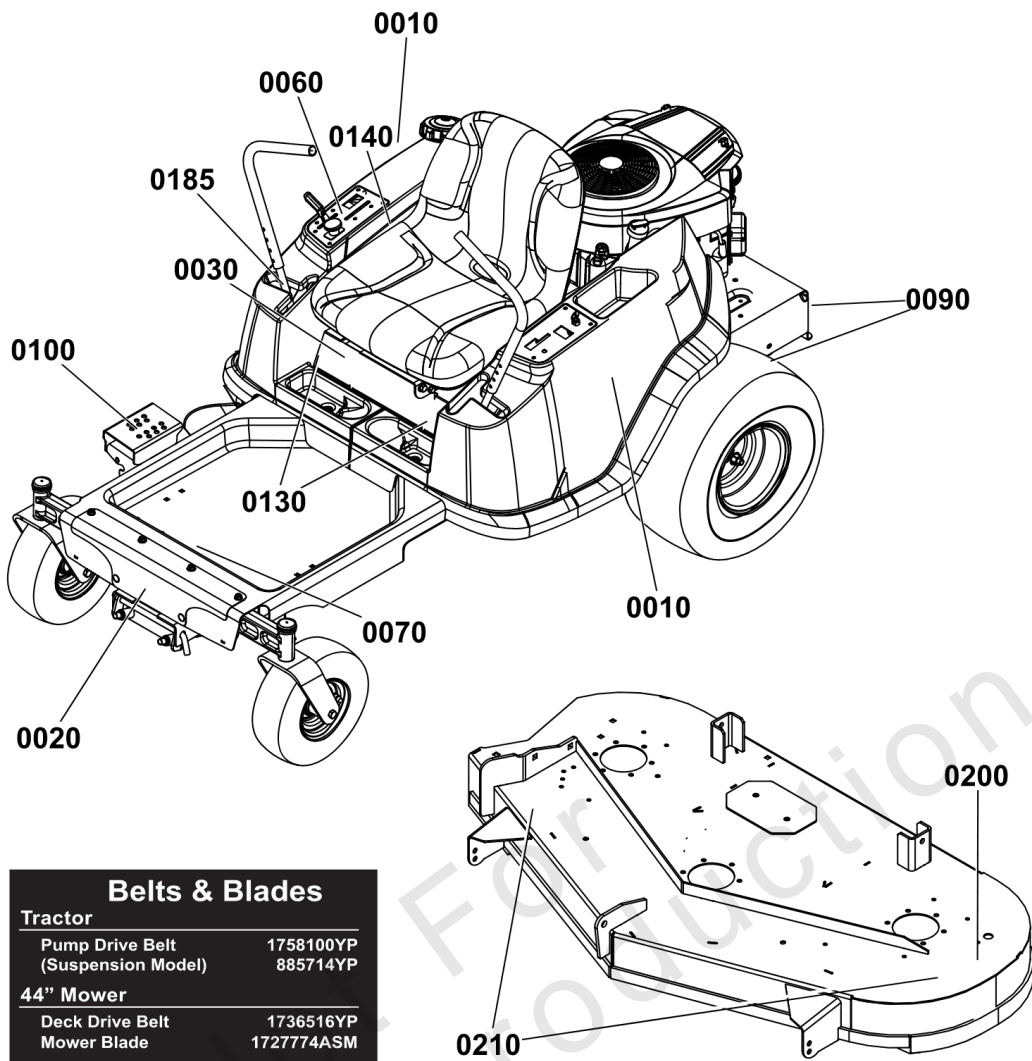

Belts & Blades	
Tractor	
Pump Drive Belt	1758100YP
(Suspension Model)	885714YP
44" Mower	
Deck Drive Belt	1736516YP
Mower Blade	1727774ASM
46" Mower	
Deck Drive Belt	1736516YP
Mower Blade	1737228BZYP
48" Mower	
Deck Drive Belt	1736516YP
Mower Blade	1759055YP

0140

Belts & Blades	
Tractor	
Pump Drive Belt	1758100YP
(Suspension Models)	885714YP
42" Mower	
Deck Drive Belt	1758101YP
Mower Blade	1758878BMYP
52" Mower	
Deck Drive Belt	1757901YP
Mower Blade	1756152AYP

0140

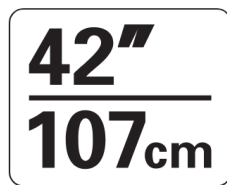

0200



0200

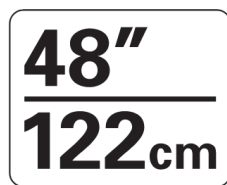

0200

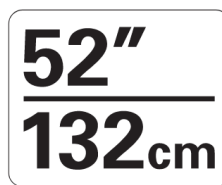

0200



0090



0210



0220



0010



0020



0030

Decals Group

REF NO	PART NO	QTY	DESCRIPTION
0010	1760170YP	2	DECAL, Logo, Snapper
0020	1750913YP	1	DECAL, SNAPPER LOGO
0030	1758364YP	1	DECAL, 360Z
0060	7105868YP	1	DECAL, ENGINE SPEED
0070	84003344	1	DECAL, MAIN, SAFETY
0070-10	1759648YP	1	DECAL, Safety Inst.
0090	1758366YP	2	DECAL, Tow Release
0100	1759253YP	1	DECAL, Height of Cut
0130	1759724YP	2	DECAL, Tracking Adjustment - ZT
0140	1759772YP	1	DECAL, Service Parts
0140	1759773YP	1	DECAL, Service Parts
0185	84011099	1	DECAL, Integrated Parking Brake
0200	1755716YP	1	DECAL, 42"/107cm
0200	1755718YP	1	DECAL, 46"/117cm
0200	1755719YP	1	DECAL, 48"/122cm
0200	1755721YP	1	DECAL, 52"/132cm
0210	7101665YP	2	DECAL, DANGER
0220	706111	2	DECAL, DISCHARGE

Electrical Group

Note: Unless noted otherwise, use the standard torque specifications

Mfg. No: 2691651-00

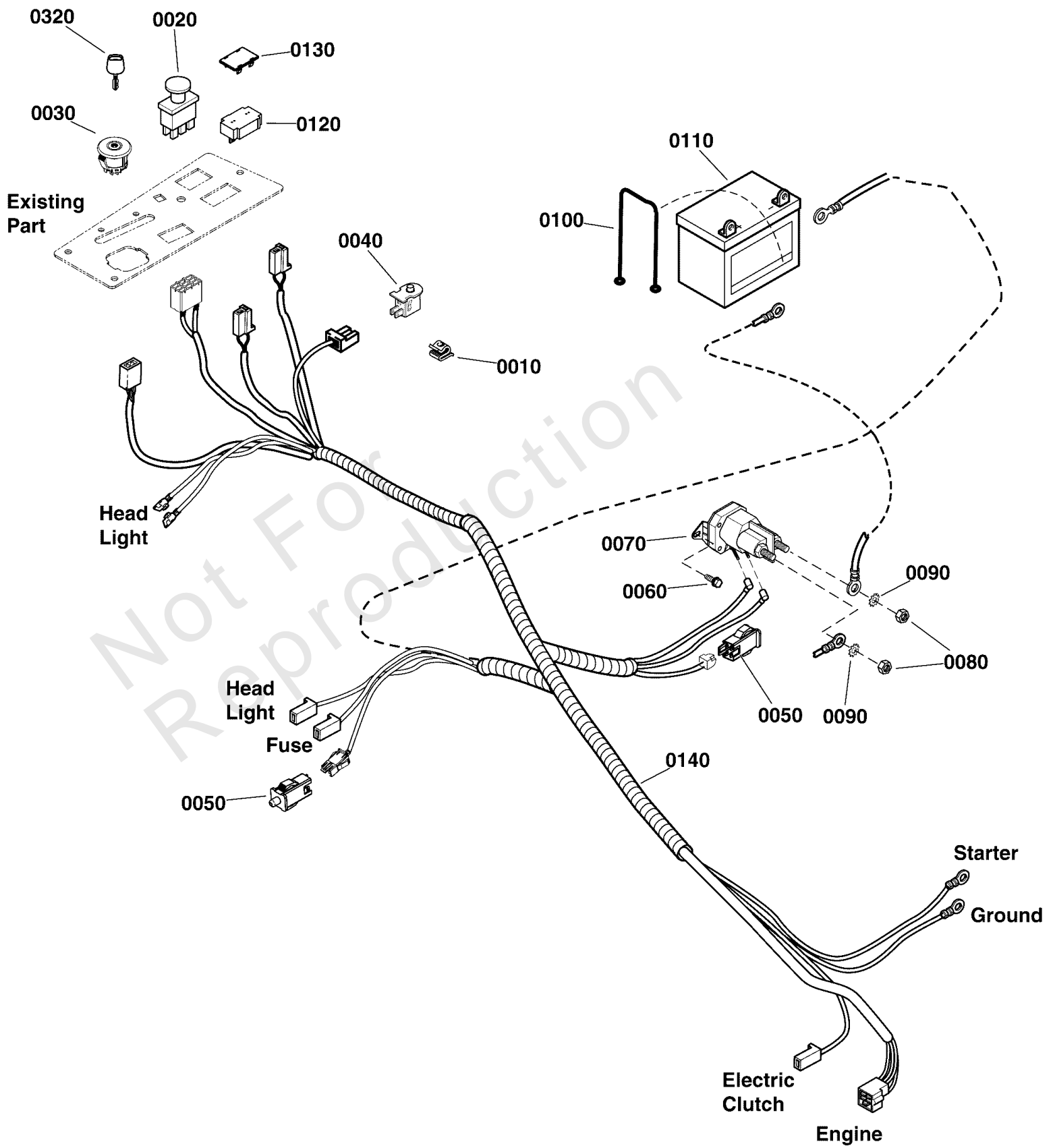

Electrical Group

REF NO	PART NO	QTY	DESCRIPTION
0010	2172434SM	2	CLIP- WIRE DIA .390
0020	1722887SM	1	SWITCH-PTO PUSH
0030	7106169YP	1	SWITCH, IGNITION, DEL
0040	7023354YP	1	SWITCH, SEAT
0050	7022886YP	2	SWITCH, DP NO/NC SNAP
0060	1960252SM	2	BOLT-RD HD SH SQ NK 1
0070	1755382YP	1	SOLENOID
0080	703463	2	NUT, GR5,1/4-20
0090	703061	3	NUT, HEX KEPS, 1/4-20
0100	1722009SM	1	STRAP, Rubber, 13"
0110	-----	1	BATTERY, 12 VOLT, 230 CCA -(Not a serviceable part)
0120	1731185SM	1	METER-HOUR DIGITAL NO
0130	1722611SM	1	PLUG-HOLE BLACK
0140	84002334	1	HARNESS ASSEMBLY
0320	7106170YP	1	KEY, Ignition Switch, Pack of 2, NA/AU

Not For Reproduction

Engine Group

Note: Unless noted otherwise, use the standard torque specifications

Mfg. No: 2691651-00

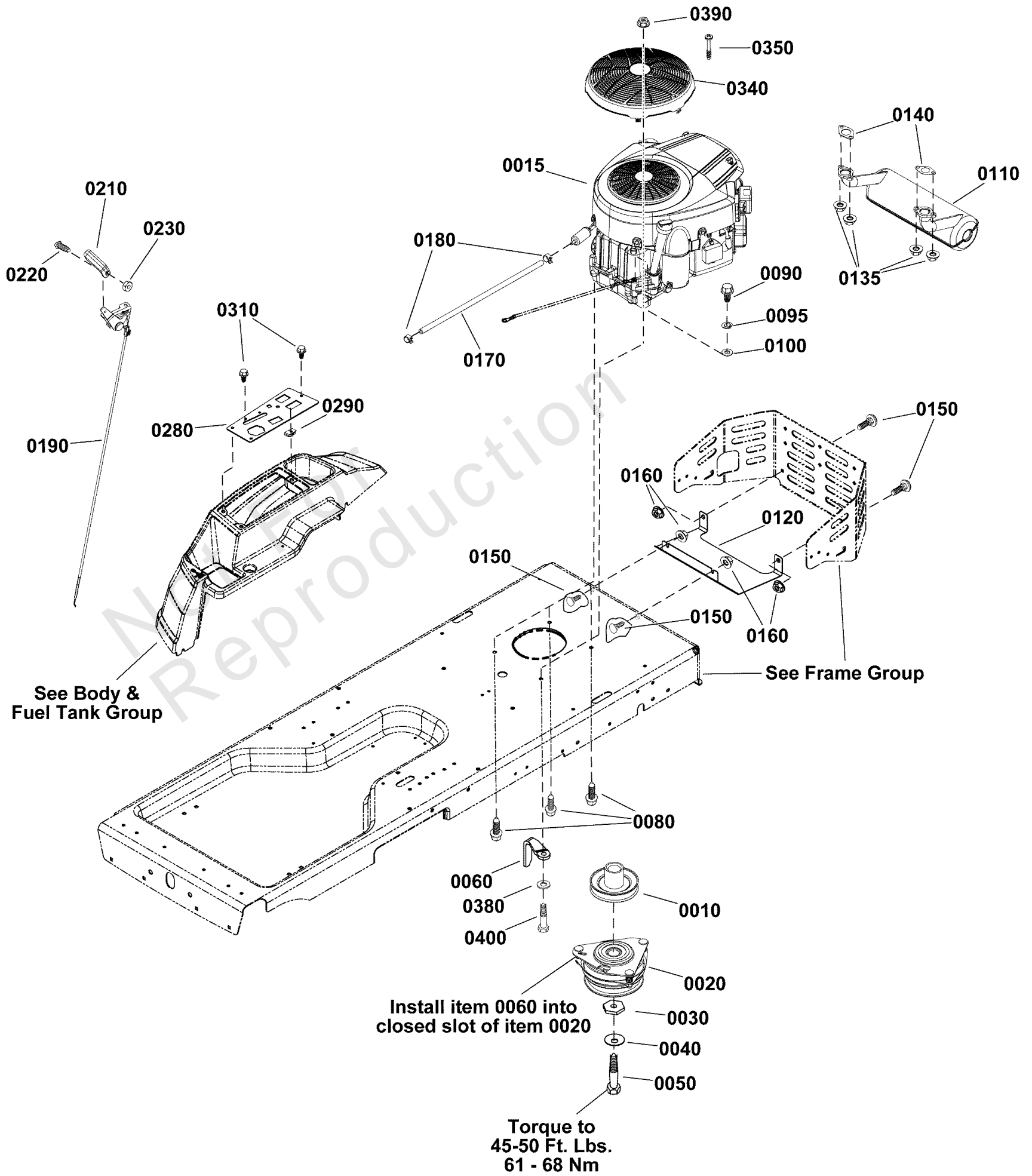

Engine Group

REF NO	PART NO	QTY	DESCRIPTION
0015	44U777-0010-G1	1	* ENGINE, 23 Gross HP B&S, Twin -(Refer to Note: *) (Engine Model: 44U777-0010-G1)
0015	44S977-0046-G1	1	* ENGINE, 25 Gross HP B&S, Twin -(Refer to Note: *) (Engine Model: 44S977-0046-G1)
0010	1757995YP	1	ASSEMBLY-PULLEY
0020	1736105SM	1	CLUTCH, ELECTRIC
0030	1708264SM	1	WASHER, HEX, 0.453ID
0040	1960769YP	2	WASHER, Belleville
0050	771023	1	CAPSCREW, Hex Head, Loctite, 7/16-20 x 3 1/2
0060	1737421AYP	1	GUIDE, Belt
0080	2828635SM	3	SCREW-HEX WSHR HD TAP
0090	703054	1	SCREW, 1/4-20X0.625
0095	703332	1	WASHER
0100	1921880SM	1	LOCKWASHER-EXTERNALTO
0110	1758350YP	1	MUFFLER
0120	1759502AYP	1	SHIELD, Heat
0135	690941	4	NUT
0140	690970	2	GASKET, Exhaust
0150	703185	4	BOLT, Round Head, Short Square Neck
0160	703115	4	NUT
0170	327290MA	1	HOSE, Fuel
0180	93053	2	CLAMP, Hose
0190	1759205YP	1	CONTROL-THROTTLE
0210	1739312YP	1	KNOB, THROTTLE
0220	797483	1	SCREW
0230	703460	1	NUT, Hex #8-32
0280	1759429AYP	1	PANEL, Control
0290	705876	3	NUT
0310	703953	5	SCREW, 1/4-20X5/8
0340	797420YP	1	GUARD, Debris Screen
0350	799359	1	SCREW
0380	5025155SM	1	WASHER, 5/16
0390	5025392SM	1	NUT, Ny Lock Flange, 5/16-18
0400	5025011X14SM	1	BOLT, 5/16-18 X 1-3/4

Footnotes:

Note:* Verify your specific engine model, reference the ID Tag located on your engine. Refer to your local Briggs & Stratton distributor for parts and service.

EVAP Group

REF NO	PART NO	QTY	DESCRIPTION
0010	7700552X6YP	2	HOSE-VAPOR
0020	7700552X12YP	1	HOSE, VAPOR,5MM ID,12
0030	5103062YP	1	FITTING, 3/16" TEE, B
0040	7700552X26YP	1	HOSE, Vapor, 5 MM ID, 26.00 LG
0050	84001895	1	FILTER, Fuel
0070	5021030SM	5	TIE WRAP, 5-1/2" LONG -(Not Shown)
0080	1760538AYP	1	BRACKET
0090	703410	2	BOLT,5/16-18X1
0100	703115	2	NUT

Not For Reproduction

Frame Group

Note: Unless noted otherwise, use the standard torque specifications

Mfg. No: 2691651-00

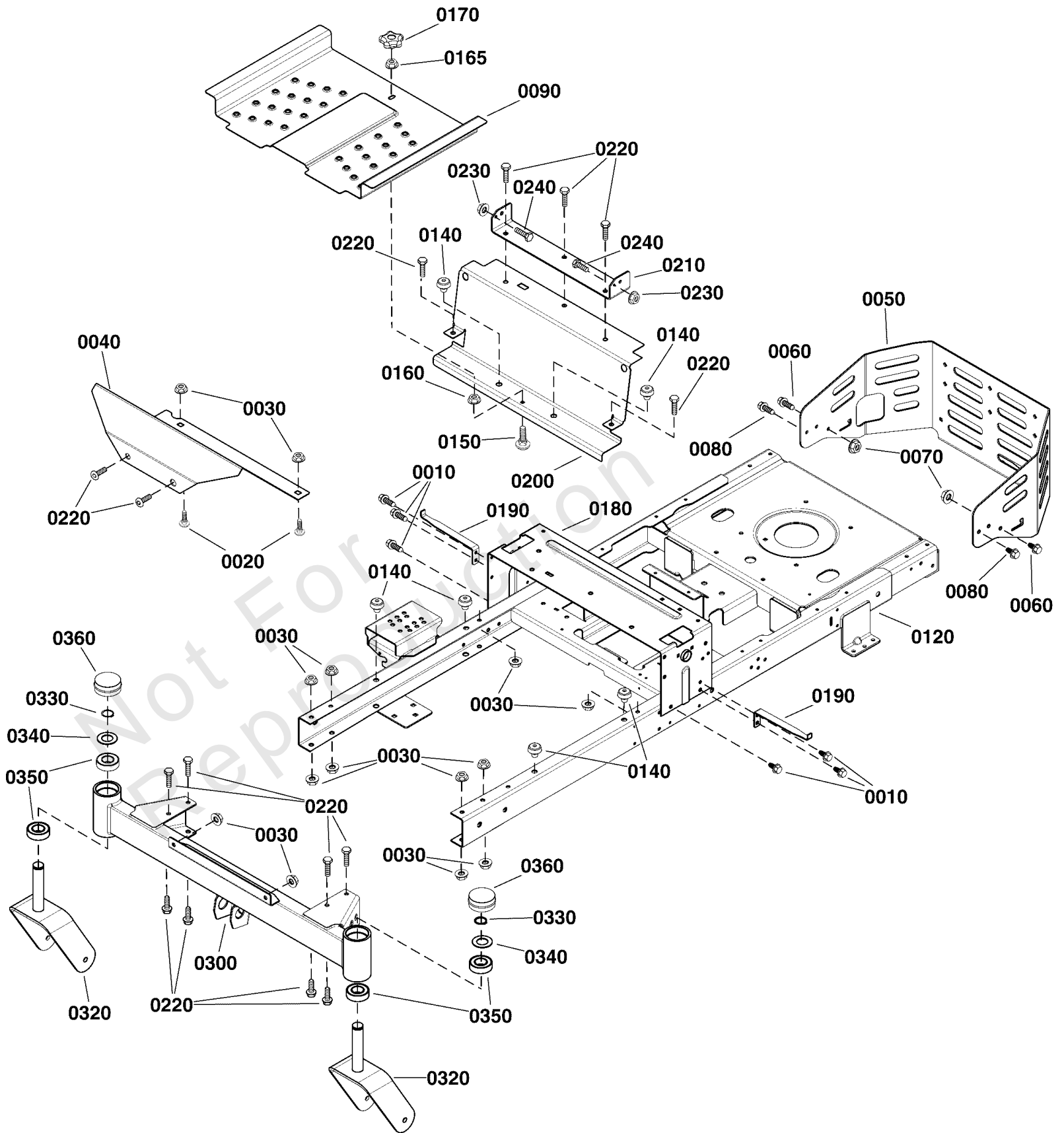

Frame Group

REF NO	PART NO	QTY	DESCRIPTION
0010	703949	6	SCREW, 5/16-18.625
0020	703448	2	BOLT, 3/8-16X.75 G5
0030	5025394SM	17	NUT, 3/8-16 HEX NYLOCK
0040	1758894DYP	1	FOOTREST
0050	1759501DYP	1	BUMPER, Rear
0060	703410	2	BOLT,5/16-18X1
0070	703115	2	NUT
0080	703228	2	SCREW, 5/16-18 X .75
0090	1757813DYP	1	PAN, Foot
0120	-----	1	FRAME, Fixed ZT -(Not a serviceable part)
0140	197546GS	6	MOUNT-VIBRATION
0150	7090496YP	1	RHSSNB, 1/4C X1 GR5 Z
0160	703233	1	NUT, 1/4-20, GR5
0165	15X143MA	1	NUT,25-20 HEX FLG CTR
0170	707785	1	KNOB
0180	1758010DYP	1	BRACKET, Control
0190	1758240AYP	2	BRACKET, Fender
0200	1757796DYP	1	BRACKET, Brand
0210	84001615	1	BRACKET, Seat
0220	707790	15	SCREW, Button Head, 3/8-16 X .88
0230	5025339YP	2	NUT
0240	707790	2	SCREW, Button Head, 3/8-16 X .88
0300	84001616	1	AXLE, Front, Red
0320	84003844	2	CASTER, Front, Red
0330	703993	2	RETAINER, EXT RING, 1
0340	703199	2	WASHER, 1
0350	1758354YP	4	BEARING
0360	5105524YP	2	CAP

Lift Group

Note: Unless noted otherwise, use the standard torque specifications

Mfg. No: 2691651-00

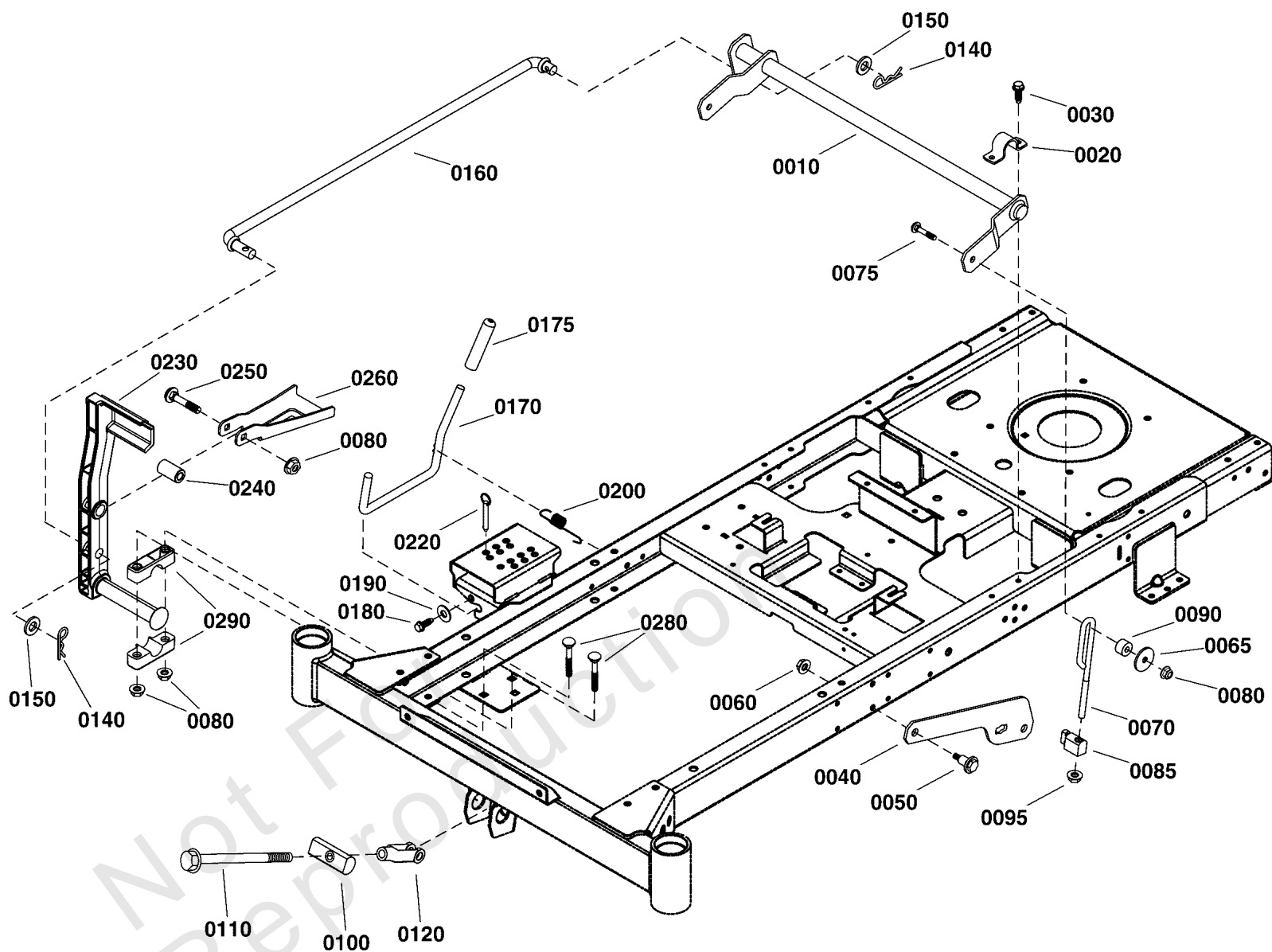

Lift Group

REF NO	PART NO	QTY	DESCRIPTION
0010	1757958AYP	1	SHAFT
0020	1720147BZYP	2	STRAP, 1 IN. DIA
0030	703949	4	SCREW, 5/16-18.625
0040	1757953AYP	2	ARM, Lift
0050	1732426SM	2	BOLT-SHLDR 5/16-18 0.
0060	703115	2	NUT
0065	5025305SM	2	WASHER, .41 X 1.75 X
0070	84003818	2	ROD, Lift
0075	703406	2	CAPSCREW,3/8-16X1.5
0080	703158	7	NUT, Hex Flange, 3/8-16
0085	84003820	2	TRUNNION
0090	5100334SM	2	SPACER
0095	770225	2	NUT
0100	1757955YP	1	PIVOT
0110	1757954YP	1	ROD
0120	5023174SM	1	CLEVIS, 1/2-20, STEEL
0140	403162MA	2	PIN, Hair, 3/32 X 1.6
0150	5025281SM	2	WASHER, 5/8" SAE
0160	1758121YP	1	ROD
0170	5105717YP	1	ROD
0175	5021880SM	1	GRIP, FOAM
0180	703054	2	SCREW, 1/4-20X0.625
0190	5025288YP	2	WASHER, 1/4 FENDER
0200	1758283YP	1	SPRING, EXTENSION
0220	5103021YP	1	HITCH PIN, 3/8 X 2-1/
0230	1758232YP	1	PEDAL
0240	1756612YP	1	BUSHING, DIFF. LOCK
0250	7900009SM	1	RHSSNB, 3/8-16 X 2-1/
0260	1758284AYP	1	BRACKET
0280	1960615SM	4	BOLT-RD HD SQ NK 3/8
0290	5100634SM	4	PIVOT BLOCK, PLASTIC

Parking Brake Group

Note: Unless noted otherwise, use the standard torque specifications

Mfg. No: 2691651-00

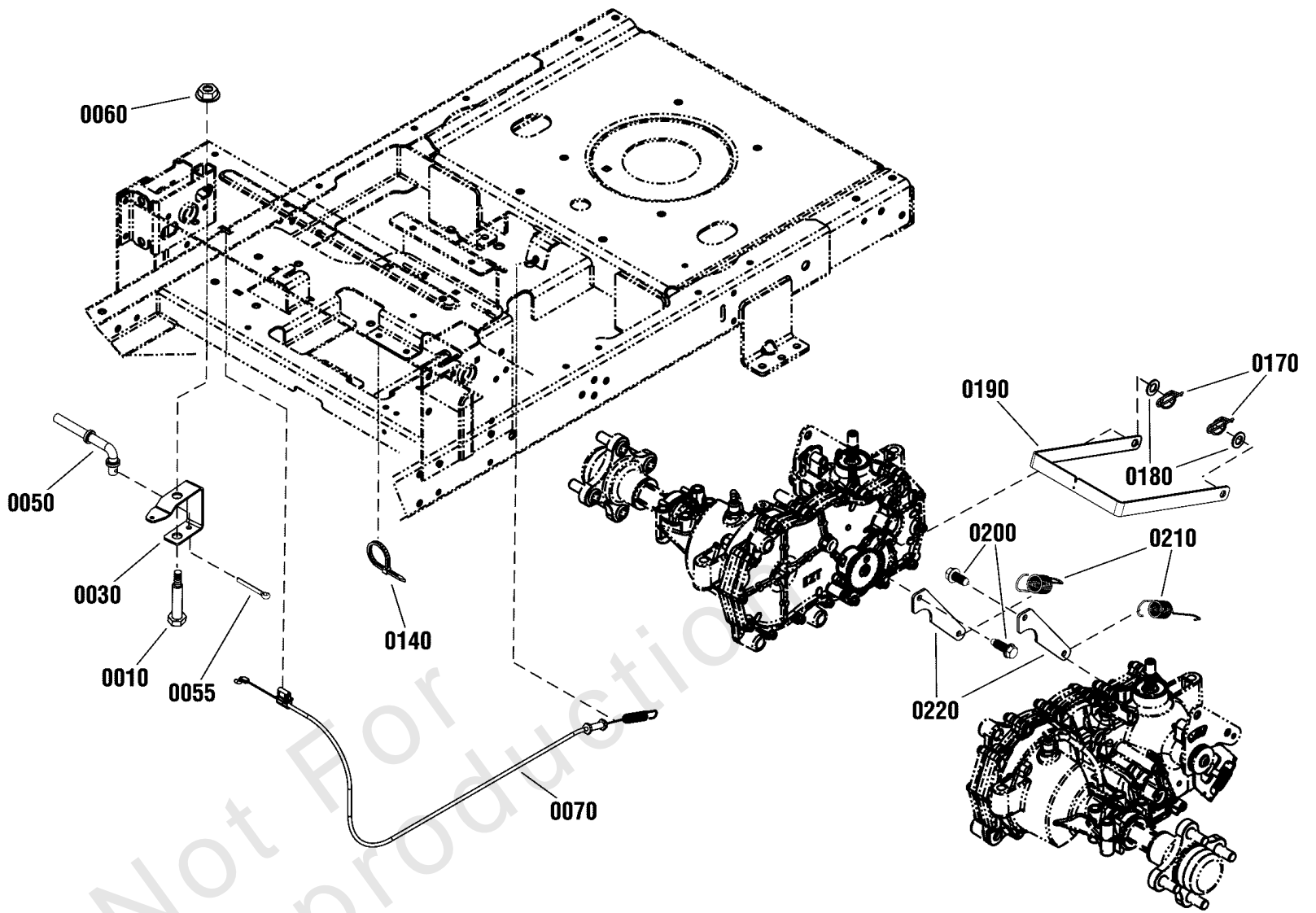

Parking Brake Group

REF NO	PART NO	QTY	DESCRIPTION
0010	1736539YP	1	BOLT, SHOULDER
0030	1758091YP	1	BELLCRANK, Parking Brake
0050	84004366	1	ROD, Parking Brake
0055	703312	1	PIN, COTTER, 3/32X.75
0060	703158	1	NUT, Hex Flange, 3/8-16
0070	1759207YP	1	CABLE, PARKING BRAKE
0140	703586	1	TIE, SELF LOCKING
0170	7091594SM	2	COTTER PIN, 1/2 SELF,
0180	703946	2	WASHER, .39IDX.72OD
0190	1758126AYP	1	ARM, Parking Brake
0200	708964	2	SCREW
0210	1758283YP	2	SPRING, EXTENSION
0220	1759349YP	2	BRACKET, Spring

Not For Reproduction

Seat Group

Note: Unless noted otherwise, use the standard torque specifications

Mfg. No: 2691651-00

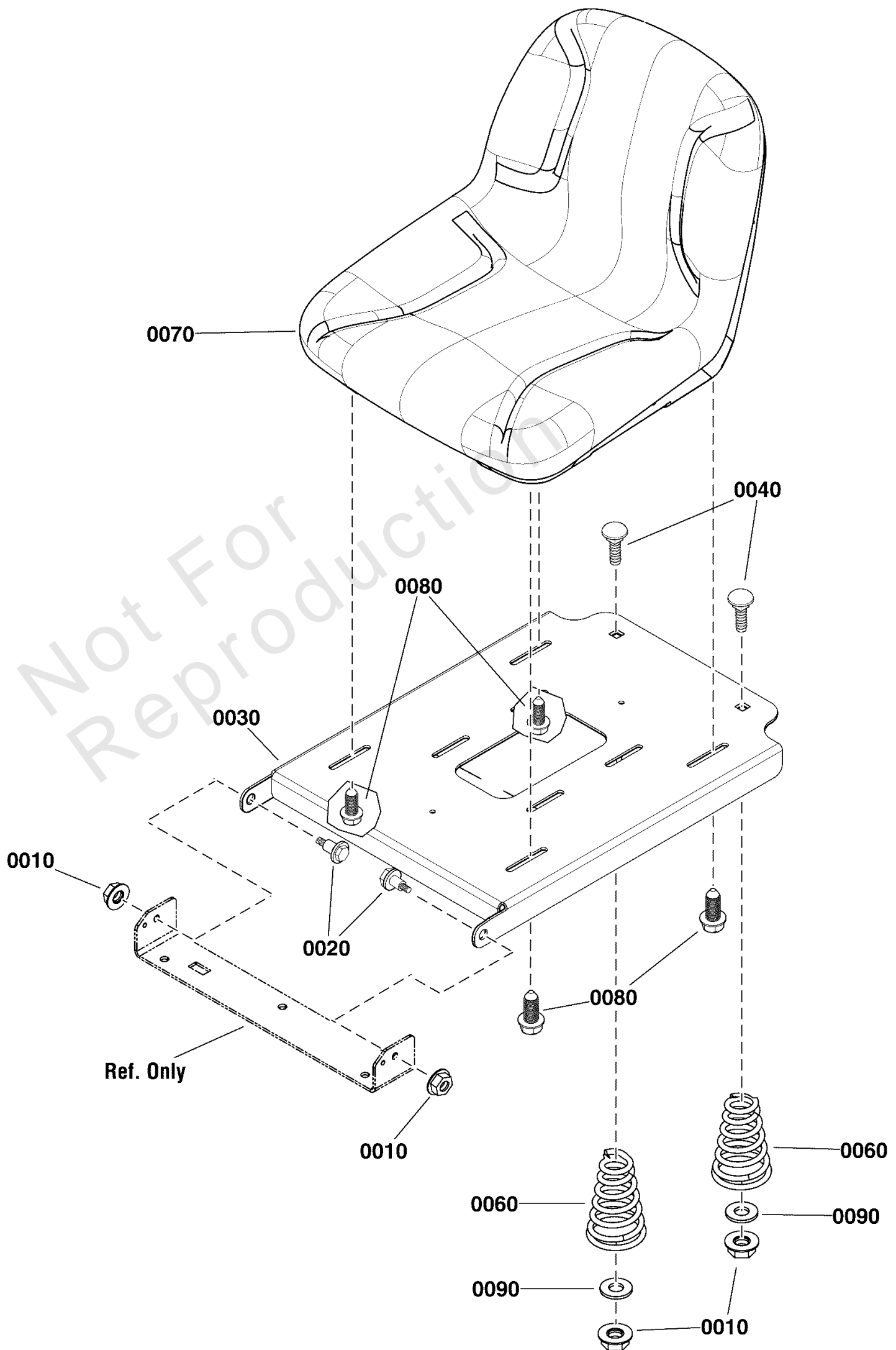

Seat Group

REF NO	PART NO	QTY	DESCRIPTION
0010	703115	4	NUT
0020	1752802YP	2	BOLT, SHLDR, 5/16-18
0030	84001618	1	SLIDE, SEAT
0040	703483	2	BOLT,5/16-18X1.000,RO
0060	1717051SM	2	SPRING, Seat
0070	84003857	1	SEAT ASSEMBLY, w/out Armrests
0080	1960667SM	4	SCREW-HEX WZ LOCK FLN
0090	704128	4	WASHER

Not For Reproduction

Transmission Group

Note: Unless noted otherwise, use the standard torque specifications

Mfg. No: 2691651-00

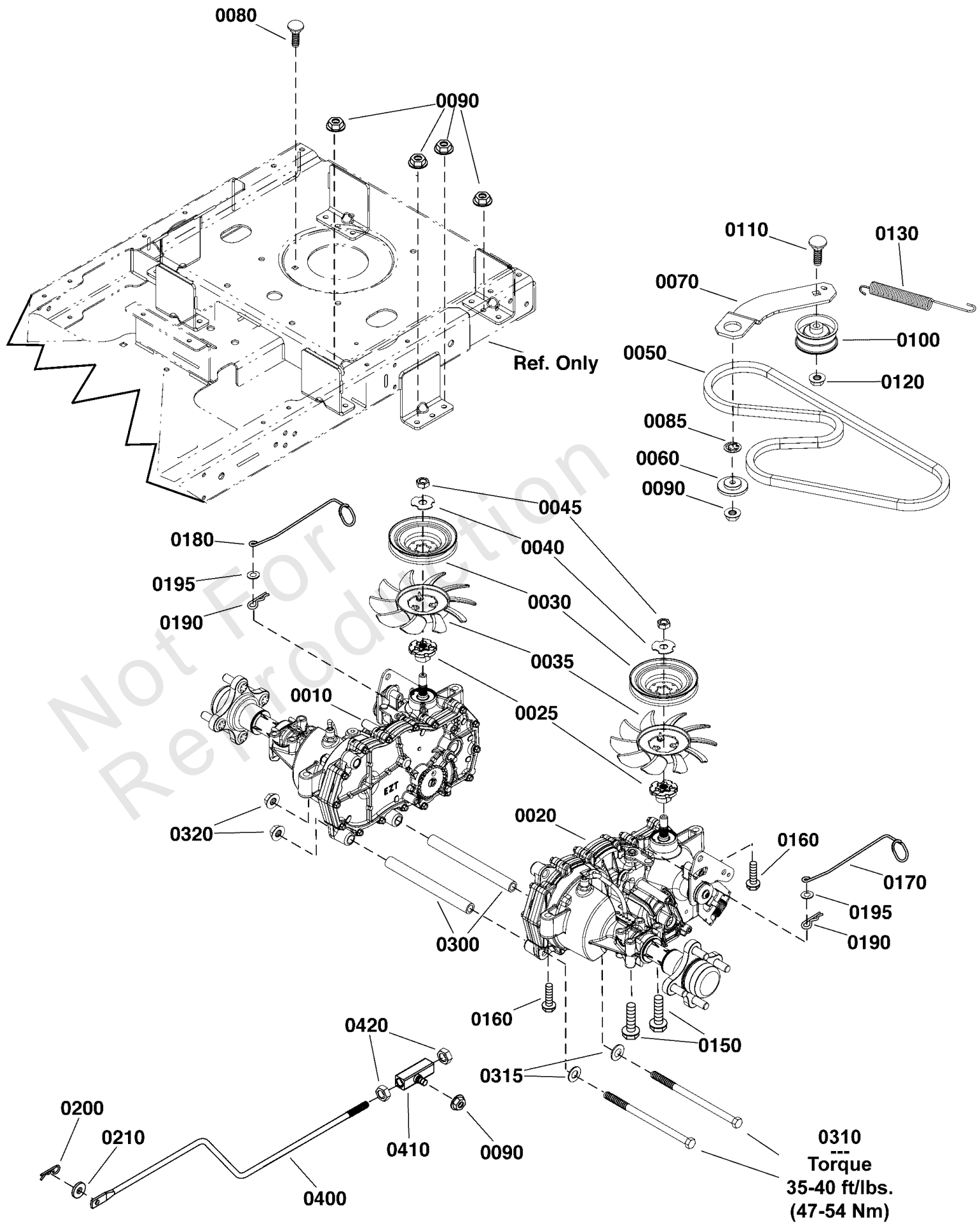

Transmission Group

REF NO	PART NO	QTY	DESCRIPTION
0010	84007995	1	TRANSAXLE -(Right side)(Refer to Note: *)
0020	84008002	1	TRANSAXLE -(Left side)(Refer to Note: *)
0025	1759450YP	2	SPACER
0030	1759447YP	2	PULLEY, Transmission
0035	1759448YP	2	FAN, Input
0040	5102914YP	2	WASHER, ZT5400, SLOTT
0045	5102916YP	2	NUT, ZT5400
0050	1758100YP	1	BELT-TRANSMISSION
0060	1727935SM	1	SPACER-PIVOT 0.330ID
0070	1758044AYP	1	ARM, Idler
0080	703800	1	BOLT, CRRG, 5/16-18X1
0085	703297	1	RETAINER, GR5, 5/16
0090	703115	11	NUT
0100	1668477SM	1	PULLEY, Idler, 2.25" OD, .378 ID
0110	703879	1	BOLT, SQ, 3/8-16X1.75
0120	703158	1	NUT, Hex Flange, 3/8-16
0130	1758045YP	1	SPRING-EXTENSION
0150	707943	4	SCREW
0160	707944	4	SCREW, Washer Head, 5/16-18 X 2 1/4
0170	1759245YP	1	ROD, Release, LH
0180	1759246YP	1	ROD, Release, RH
0190	703430	2	PIN, 13X1.19
0195	703332	2	WASHER
0200	703300	2	PIN, 3/32 X 1.6
0210	704128	2	WASHER
0300	1759392YP	2	SPACER, Transmission
0310	707945	2	CAPSCREW, HexHead, 7/16-14 X 11 1/4
0315	703183	2	WASHER, 7/16 ID X.065
0320	1930650SM	2	NUT-HEX FLANGE 7/16-1
0400	84002180	2	CONTROL ROD, Transmission
0410	84002181	2	TRUNNION
0420	7090460SM	4	NUT, 7/16F, GR5, Hex

Footnotes:

Note: *See your local Hydro Gear dealer for parts and service.

Wheel & Tire Group

Note: Unless noted otherwise, use the standard torque specifications

Mfg. No: 2691651-00

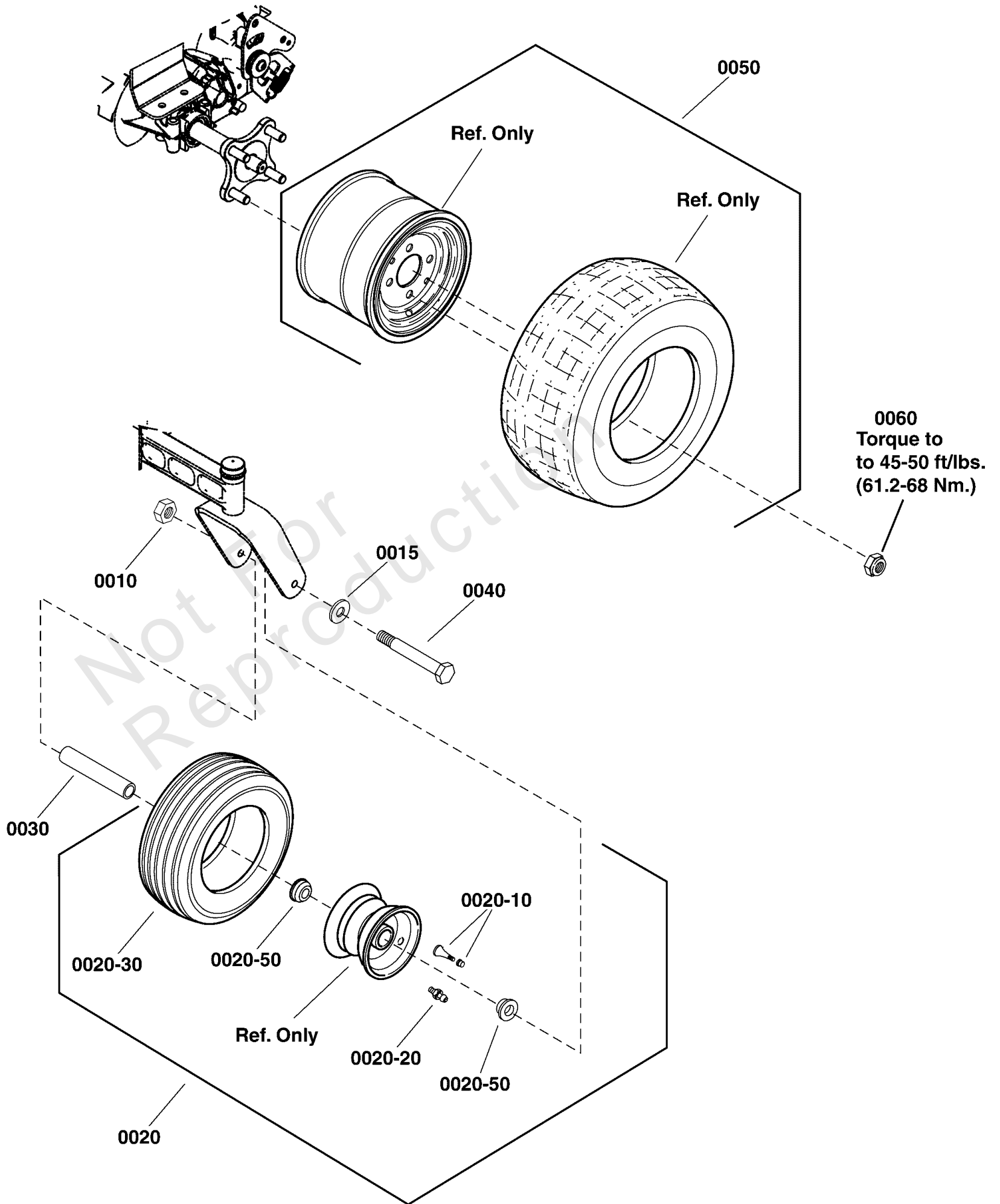

Wheel & Tire Group

REF NO	PART NO	QTY	DESCRIPTION
0010	1930650SM	2	NUT-HEX FLANGE 7/16-1
0015	703183	2	WASHER, 7/16 ID X.065
0020	84003826	2	WHEEL ASSEMBLY
0020-10	2172353SM	4	VALVE STEM & CAP
0020-20	7104428YP	2	ZERK, Grease
0020-30	84004709	2	TIRE
0020-50	84003829	4	BEARING, BALL
0030	84003827	2	TUBE, Caster Wheel
0040	84003828	2	CAPSCREW
0050	1759161YP	2	ASSEMBLY, Wheel & Tire, 20 X 8-8 (K505)
0060	5020601SM	8	NUT, 1/2-20, FOR WHEEL BOLT SILVER

Not For Reproduction

Hardware Identification & Torque Specifications

Torque Specification Chart								
FOR STANDARD METRIC MACHINE HARDWARE (Tolerance ± 20%)								
Property Class	5.6		8.8		10.9		12.9	
	Class 5.6		Class 8.8		Class 10.9		Class 12.9	
Size Of Hardware	in/lbs	Nm.	in/lbs	Nm.	in/lbs	Nm.	in/lbs	Nm.
	ft/lbs		ft/lbs		ft/lbs		ft/lbs	
M3	5.88	.56	13.44	1.28	19.2	1.80	22.92	2.15
M4	13.44	1.28	30.72	2.90	43.44	4.10	52.56	4.95
M5	26.4	2.50	60.96	5.75	5.97	8.10	7.15	9.7
M6	44.64	4.3	7.3	9.9	10.3	14	12.1	16.5
M7	5.2	7.1	12.1	16.5	16.9	23	19.9	27
M8	7.7	10.5	17.7	24	25	34	29	40
M10	15	21	35	48	50	67	59	81
M12	26	36	61	83	86.2	117	103	140
M14	42	58	101	132	136	185	162	220
M16	64	88	147	200	210	285	250	340
M18	89	121	202	275	287	390	346	470
M20	126	171	290	390	405	550	486	660
M22	169	230	390	530	559	745	656	890
M24	217	295	497	375	708	960	840	1140
M27	320	435	733	995	1032	1400	1239	1680
M30	435	590	995	1350	1401	1900	1681	2280
M33	590	800	1349	1830	1902	2580	2278	3090
M36	759	1030	1740	2360	2441	3310	2935	3980
M39	988	1340	2249	3050	3163	4290	3798	5150

Torque Specification Chart						
FOR STANDARD MACHINE HARDWARE (Tolerance ± 20%)						
Hardware Grade	No Marks		SAE Grade 5		SAE Grade 8	
	SAE Grade 2		SAE Grade 5		SAE Grade 8	
Size Of Hardware	in/lbs	Nm.	in/lbs	Nm.	in/lbs	Nm.
	ft/lbs		ft/lbs		ft/lbs	
8-32	19	2.1	30	3.4	41	4.6
8-36	20	2.3	31	3.5	43	4.9
10-24	27	3.1	43	4.9	60	6.8
10-32	31	3.5	49	5.5	68	7.7
1/4-20	66	7.6	8	10.9	12	16.3
1/4-28	76	8.6	10	13.6	14	19.0
5/16-18	11	15.0	17	23.1	25	34.0
5/16-24	12	16.3	19	25.8	29	34.0
3/8-16	20	27.2	30	40.8	45	61.2
3/8-24	23	31.3	35	47.6	50	68.0
7/16-14	30	40.8	50	68.0	70	95.2
7/16-20	35	47.6	55	74.8	80	108.8
1/2-13	50	68.0	75	102.0	110	149.6
1/2-20	55	74.8	90	122.4	120	163.2
9/16-12	65	88.4	110	149.6	150	204.0
9/16-18	75	102.0	120	163.2	170	231.2
5/8-11	90	122.4	150	204.0	220	299.2
5/8-18	100	136	180	244.8	240	326.4
3/4-10	160	217.6	260	353.6	386	525.0
3/4-16	180	244.8	300	408.0	420	571.2
7/8-9	140	190.4	400	544.0	600	816.0
7/8-14	155	210.8	440	598.4	660	897.6
1-8	220	299.2	580	788.8	900	1,244.0
1-12	240	326.4	640	870.4	1,000	1,360.0

The guides and ruler furnished below are designed to help you select the appropriate hardware.



Nut, M8

Thread Diameter (mm)

Inside Diameter (in) Threads per inch

Nut, 1/2-16



Screw, M8- 1.25 x 25

Thread Diameter (mm) Distance between threads (mm) Body Length (mm)

Body Diameter Threads per inch Body Length (in)

Screw, 1/2- 16 x 2



Standard Hardware Sizing

When a washer or nut is identified as 1/2" (M8), this is the *Nominal size*, meaning the *inside diameter* is 1/2 inch (8mm metric thread diameter); if a second number is present it represents the *threads per inch* (distance between threads).

When bolt or capscrew is identified as 1/2 - 16 x 2" (M8 - 1.25 x 50), this means the *Nominal size*, or body diameter is 1/2 inch (8mm metric thread diameter), the second number, 16, represents the *threads per inch*, (*distance between threads*). The final number is the body length of the bolt or screw, 2 inches (50mm).

NOTES

- These torque values are to be used for all hardware excluding: locknuts, self-tapping screws, thread forming screws, sheet metal screws and socket head setscrews.
- Recommended seating torque values for locknuts:
 - for prevailing torque locknuts - use 65% of grade 5 torques.
 - for flange whizlock nuts and screws - use 135% of grade 5 torques.
- Unless otherwise noted on assembly drawings, all torque values must meet this specification.

Common Hardware Types

Hex Head Capscrew



Washer



Carriage Bolt



Hex Nut

Wrench & Fastener Size Guide

1/4" Bolt or Nut Wrench—7/16"	5/16" Bolt or Nut Wrench—1/2"	3/8" Bolt or Nut Wrench—9/16"	7/16" Bolt or Nut Wrench (Bolt)—5/8" Wrench (Nut)—11/16"	1/2" Bolt or Nut Wrench—3/4"
M6 Bolt or Nut Wrench—10mm	M8 Bolt or Nut Wrench—13mm	M10 Bolt or Nut Wrench—17mm	M12 Bolt or Nut Wrench—19mm	M14 Bolt or Nut Wrench—22mm

