



# Parts Manual

Mfg. No: 2691817-00  
ZT2561, 61" Fabricated Mower Deck,  
25HP B&S, 360Z Series

1697378A-00 - Kit, ZT Catcher, Twin, CS. ....  
1697379A-00 - Turbo, 61" Fabricated Mower Deck. ....  
1697403-00 - Grass Mulcher Kit, 61" .....

Not For  
Reproduction

<b>Model Components</b>	<b>Page</b>
61" Mower Deck - Clutch & Support Group.....	4
61" Mower Deck - Housing, Arbors & Blade Group.....	6
Body & Fuel Tank Group.....	8
Controls Group.....	10
Decals Group - Brand & Model.....	12
Decals Group - Safety & Operation.....	14
Electrical Group.....	16
Electrical Schematic - Charging Circuit - B&S 44C777 & 44T977.....	18
Electrical Schematic - Cranking Circuit - B&S 44C777 & 44T977.....	20
Electrical Schematic - Ignition Grounding Circuit/Op. Pres. - B&S 44C777 & 44T977.....	22
Electrical Schematic - PTO Clutch Circuit - B&S 44C777 & 44T977.....	24
Engine Group.....	26
EVAP Group.....	28
Frame Group.....	30
Lift Group.....	32
Parking Brake Group.....	34
Seat Group.....	36
Transmission Group.....	38
Wheel & Tire Group.....	40
Torque Specification Chart.....	42

Not For  
Reproduction

# 61" Mower Deck - Clutch & Support Group

Note: Unless noted otherwise, use the standard torque specifications

Mfg. No: 2691817-00

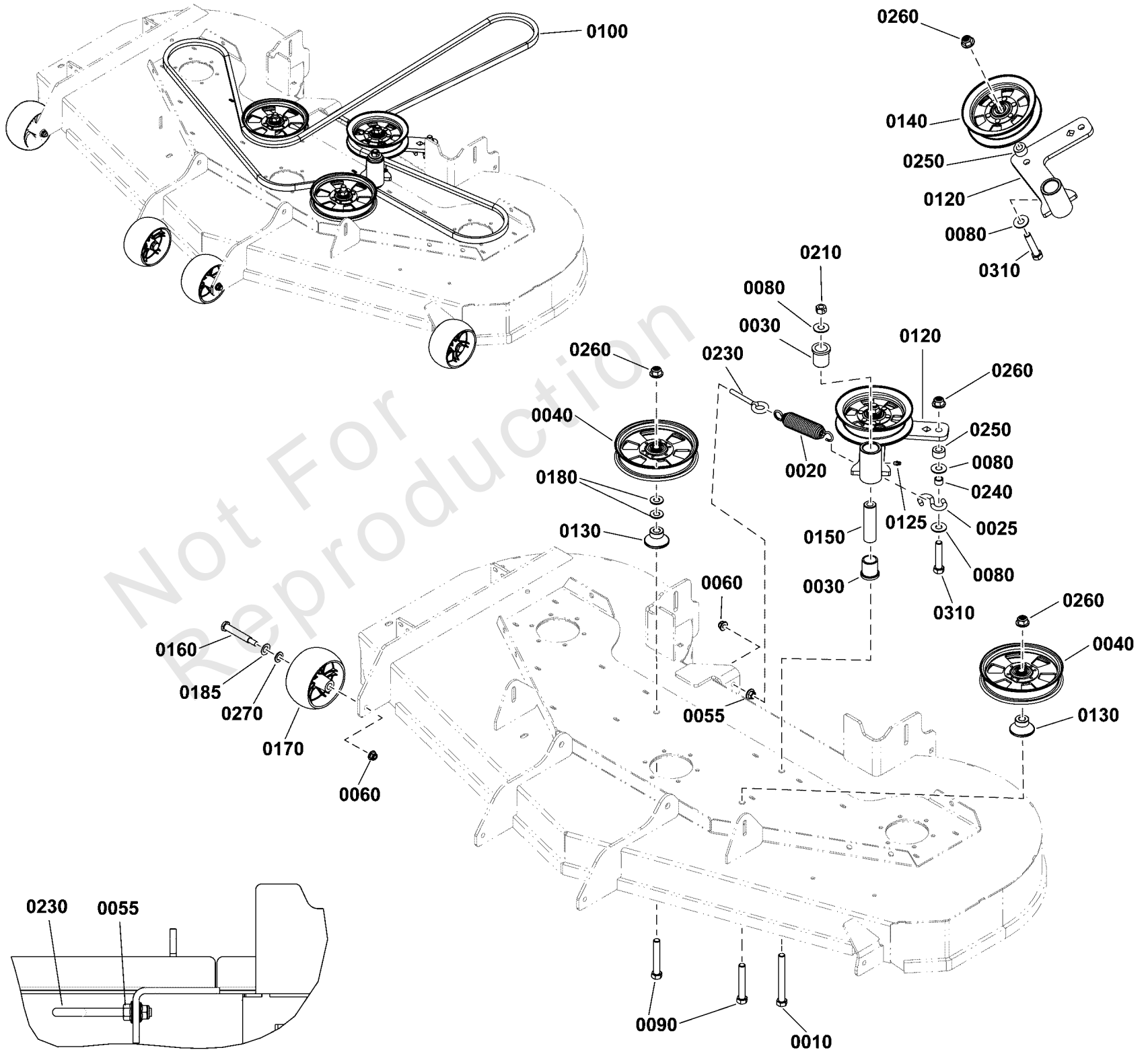

## 61" Mower Deck - Clutch & Support Group

REF NO	PART NO	QTY	DESCRIPTION
0010	5025017X36SM	1	BOLT, 1/2-13 X 4-1/2"
0020	5100633YP	1	SPRING, EXT
0025	5104011YP	1	HOOK, 5/16 S-HOOK, OP
0030	5021541SM	2	BUSHING, FLANGE
0040	5104717YP	2	PULLEY
0055	5025128SM	1	NUT, 3/8-16 HEX SERRA
0060	5025394SM	5	NUT, 3/8-16 HEX NYLOCK
0080	703451	4	WASHER, FLAT
0090	5025017X26SM	2	BOLT, 1/2-13
0100	84006541	1	BELT
0120	84007069	1	WELDMENT
0125	5020095SM	1	GREASE FITTING, 1/4-2
0130	5103430YP	2	IDLER MNT
0140	5104716YP	1	PULLEY, IDLER
0150	5045022SM	1	SPACER, .52 X 1.00 X
0160	1736539YP	4	BOLT, SHOULDER
0170	1736896YP	4	WHEEL, GAUGE
0180	5025158SM	2	WASHER, 1/2" SAE
0185	0020X3MA	4	WASHER, SPRING .52X.99
0210	5025332SM	1	NUT - SIDE LOCK
0230	5025429SM	1	EYEBOLT - 3/8-16
0240	5020870SM	1	INSERT, BEARING
0250	5101162YP	2	SPACER
0260	5025396SM	4	NUT, Hex Flange, 1/2-13
0270	703128	4	WASHER
0310	5025017X20SM	2	BOLT, 1/2-13 X 2-1/2

# 61" Mower Deck - Housing, Arbors & Blade Group

Note: Unless noted otherwise, use the standard torque specifications

Mfg. No: 2691817-00

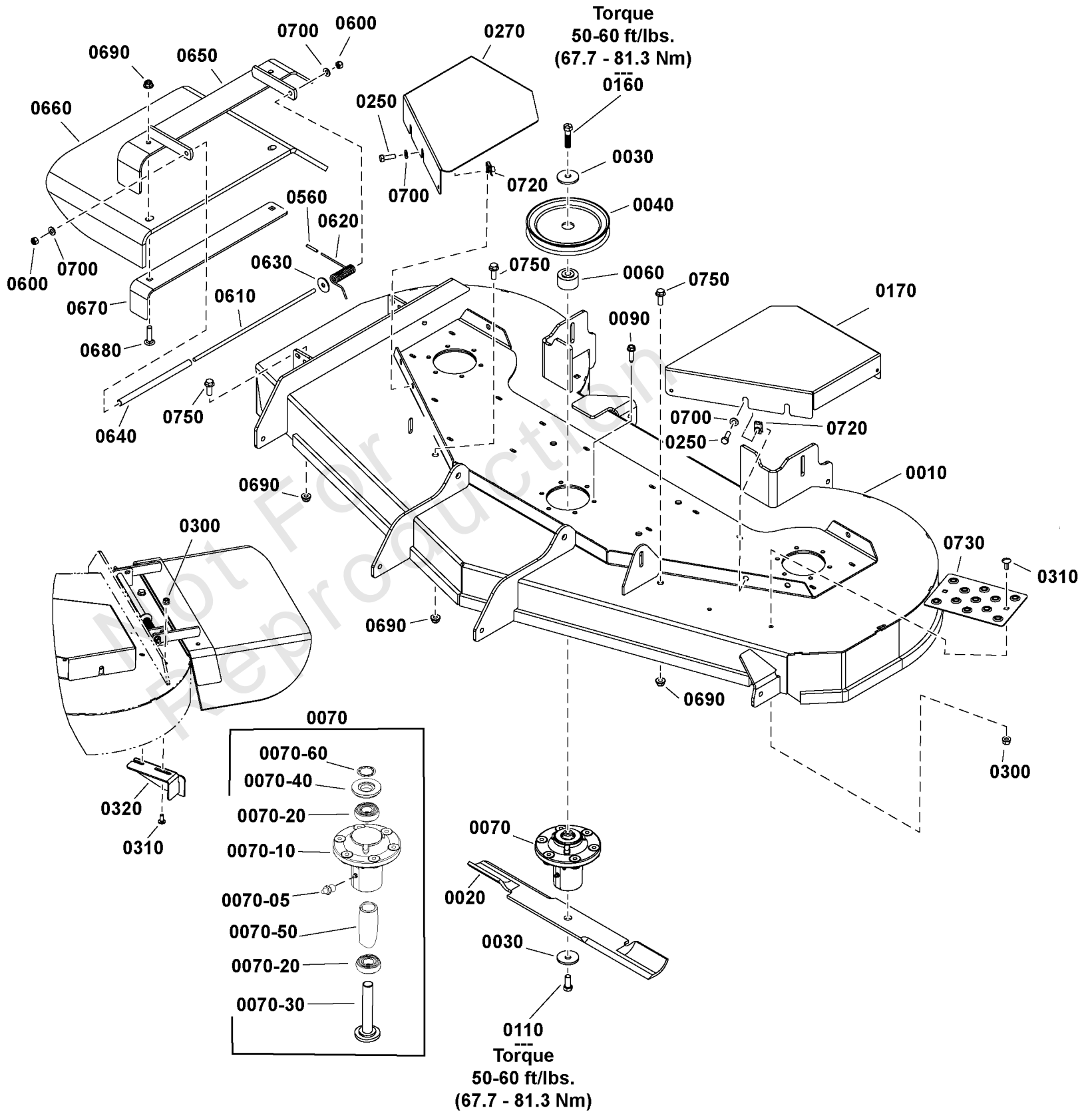

## 61" Mower Deck - Housing, Arbors & Blade Group

REF NO	PART NO	QTY	DESCRIPTION
0010	84006947	1	HOUSING, Mower Deck w/Decals, 61" FAB
0020	5104045YP	3	BLADE, .187 X 2.50 X 21.00
0030	1656916SM	6	WASHER, SPRING 0.475I
0040	84006900	3	PULLEY
0060	706363	3	SPACER, HUB
0070	84003174	3	ARBOR ASSEMBLY
0070-05	1704314SM	3	LUBE FITTING, .250 DR
0070-10	84003653	1	HOUSING ASSEMBLY
0070-20	1735399YP	1	BEARING, Ball, 20mm
0070-30	84003655		SHAFT, Mower Spindle
0070-40	84003166	1	COVER, ARBOR
0070-50	84003167	1	SPACER, BEARING
0070-60	1960766YP	1	RING, SELF LOCKING
0090	703167	18	SCREW
0110	703579	3	HHCS, 7/16-14X1.25
0160	84007038	3	CAPSCREW, Hex Head, 7/16-14 X 2
0170	84006930	1	COVER, ARBOR
0250	5025011X8SM	6	CAPSCREW, Hex Head, 5/16-18 X 1
0270	84006932	1	COVER, ARBOR
0300	5025392SM	4	NUT, Ny Lock Flange, 5/16-18
0310	5025145X6SM	4	BOLT, 5/16-18 X 3/4",
0320	84003247	1	DEFLECTOR
0560	5023489SM	1	CAP, PROTECTOR, .120
0600	5025045SM	2	NUT, 5/16-24 HEX NYLO
0610	5042555SM	1	ROD, BRAKE LINKAGE
0620	5023385SM	1	SPRING, TORSION
0630	5025164SM	1	WASHER, 5/16" FENDER
0640	5050086X8SM	1	TORSION SPRING SPACER
0650	5413404AYP	1	MOUNT, Discharge
0660	5413498YP	1	CHUTE, Discharge
0670	5413401AYP	1	SUPPORT
0680	5025146X12YP	2	BOLT, 3/8-16 X 1-1/2
0690	5025394SM	4	NUT, 3/8-16 HEX NYLOCK
0700	5025155SM	8	WASHER, 5/16
0720	5022308SM	6	BODY CLIP, 5/16-18 X
0730	84006929	1	PLATE, BASE
0750	703448	2	BOLT, 3/8-16X.75 G5

# Body & Fuel Tank Group

Note: Unless noted otherwise, use the standard torque specifications

Mfg. No: 2691817-00

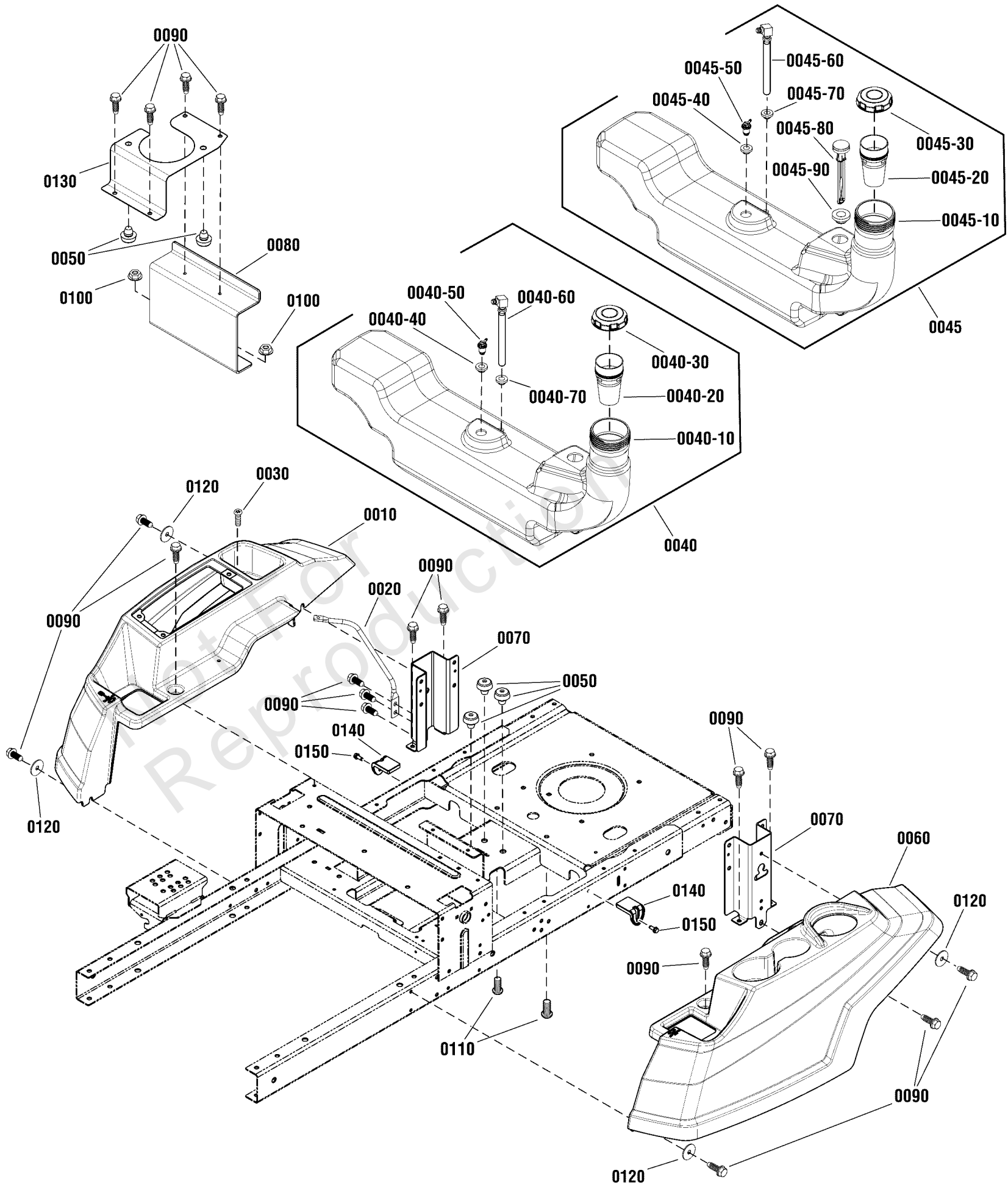



## Body & Fuel Tank Group

REF NO	PART NO	QTY	DESCRIPTION
0010	84008779	1	FENDER, Right
0020	1759369YP	1	ROD, Support
0030	703953	1	SCREW, 1/4-20X5/8
0040	1758202YP	1	FUEL TANK ASSEMBLY, No Fuel Gauge -(Includes item Nos. 0040-10 thru 0040-70)
0040-10	-----	1	TANK, Fuel -(Order item 0040)
0040-20	-----	1	NECK, Fuel Filter -(Order item 0040)
0040-30	1758314YP	1	CAP-FUEL TANK
0040-40	799624	1	GROMMET
0040-50	770046	1	VENT, Remote
0040-60	1758927YP	1	TUBE-PICK UP
0040-70	1726400SM	1	BUSHING
0045	1758919YP	1	FUEL TANK ASSEMBLY. W / Fuel Gauge -(Includes item Nos. 0045-10 thru 0045-90)
0045-10	-----	1	TANK, Fuel -(Order item 0045)
0045-20	-----	1	NECK, Fuel Filter -(Order item 0045)
0045-30	1758314YP	1	CAP-FUEL TANK
0045-40	799624	1	GROMMET
0045-50	770046	1	VENT, Remote
0045-60	1758927YP	1	TUBE-PICK UP
0045-70	1726400SM	1	BUSHING
0045-80	1758928YP	1	GAUGE-FUEL
0045-90	84004692	1	GROMMET
0050	197546GS	5	MOUNT-VIBRATION
0060	1758076YP	1	FENDER-LEFT
0070	1758239AYP	2	SUPPORT-FENDER
0080	84002196	1	BRACKET
0090	703228	18	SCREW, 5/16-18 X .75
0100	5025394SM	2	NUT, 3/8-16 HEX NYLOCK
0110	704038	2	SCREW
0120	1960044SM	4	WASHER-0.312(0.33IDX1
0130	1759140AYP	1	STRAP-FUEL TANK
0140	1760244YP	2	SUPPORT, Fuel Tank
0150	703054	2	SCREW, 1/4-20X0.625

# Controls Group

Note: Unless noted otherwise, use the standard torque specifications

Mfg. No: 2691817-00



## Controls Group

REF NO	PART NO	QTY	DESCRIPTION
0010	1758372YP	2	HANDLE, CONTROL
0020	703115	4	NUT
0030	703483	4	BOLT,5/16-18X1.000,RO
0040	1757965YP	2	ARM, UPPER CONTROL
0050	707624	2	BOLT,SHLDR,5/16-18
0060	1757964YP	2	ARM, LOWER CONTROL
0070	2176440SM	4	BUSHING-0.765IDX
0080	703949	10	SCREW, 5/16-18.625
0090	1758087AYP	2	PIVOT, Inner Control
0100	5022308SM	2	BODY CLIP, 5/16-18 X
0110	1758373YP	2	KNOB, 5/16-18 X 2.5
0120	1650347SM	2	SPRING-COMP 0.50 IDX
0130	5025211SM	4	PIN, HAIR, .0585" X 1
0140	1758463YP	2	ROD, DAMPNER MNT
0150	84001625	2	DAMPENER
0160	1759182YP	2	LATCH, CONTROL ARM
0170	703101	4	BOLT,1/4-20X.75
0180	703463	4	NUT, GR5,1/4-20
0190	707625	2	WSHR, 3 WAVE, .750
0200	703902	2	NUT, HEX, 5/16-18

**Decals Group - Brand & Model**

Note: Unless noted otherwise, use the standard torque specifications

Mfg. No: 2691817-00

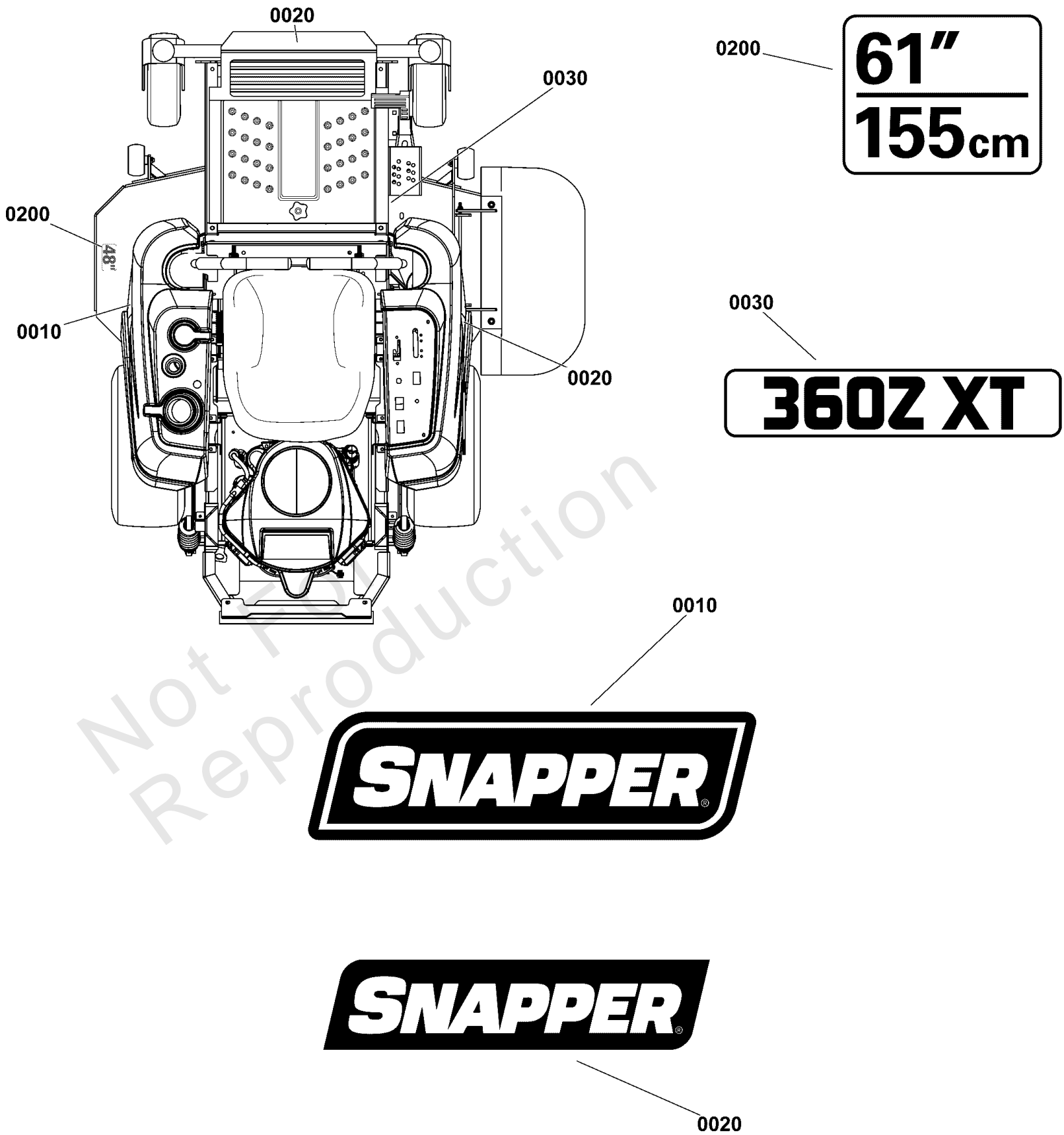

***Decals Group - Brand & Model***

---

REF NO	PART NO	QTY	DESCRIPTION
0010	1760170YP	2	DECAL, Logo, Snapper
0020	1750913YP	2	DECAL, SNAPPER LOGO
0030	84006941	1	DECAL, 360Z XT
0200	1755723YP	1	DECAL, MOWER WIDTH 61IN/155CM

Not For Reproduction

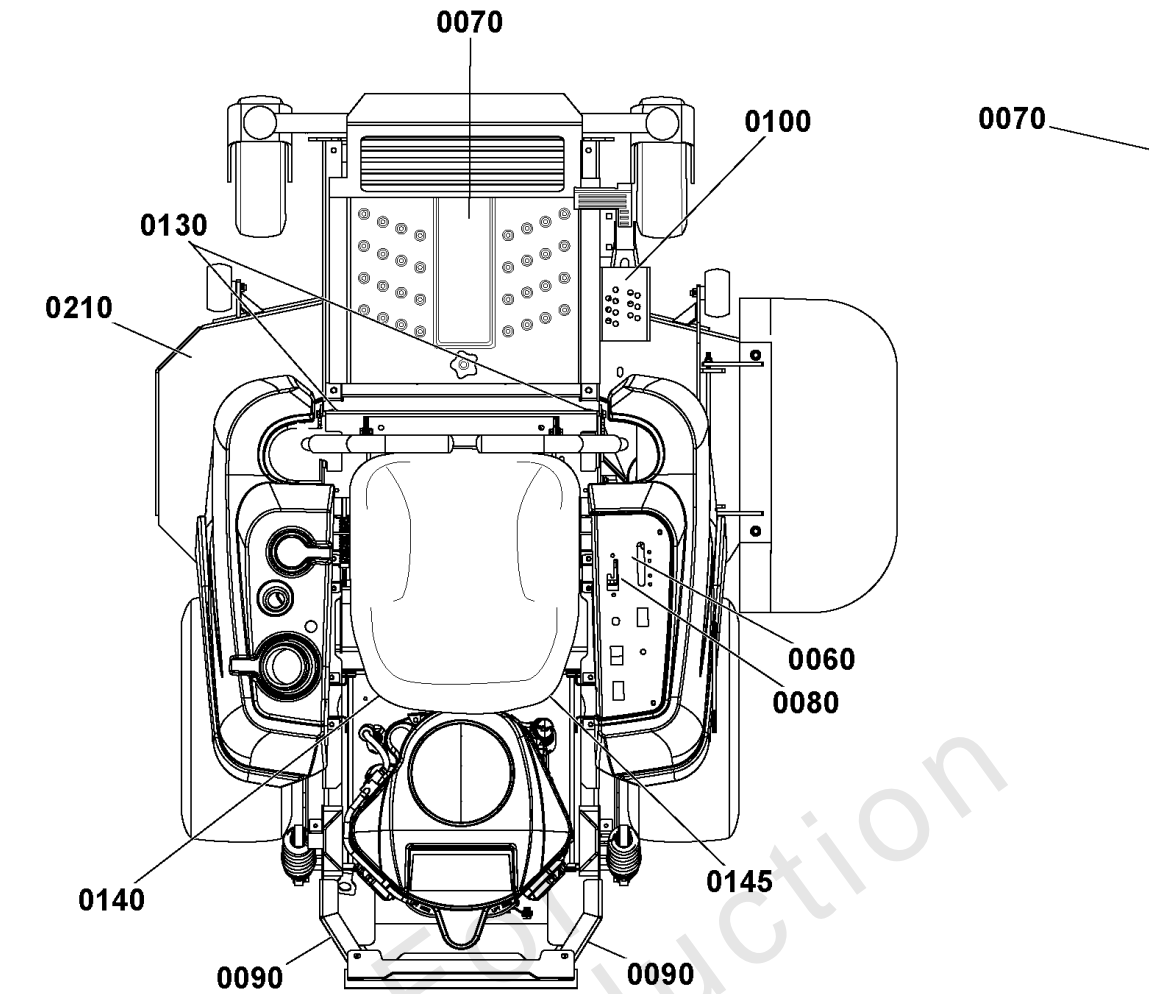

**⚠ DANGER**

**Amputation hazard**  
Rotating blades cut off arms and legs.

- Stop the mower when children or others are near.
- Do not carry riders (especially children) even with the blades off. They may fall off or return for another ride when you are not expecting it.
- Look down, behind and to the side before changing directions.

**Loss of control and roll-over hazard**  
Operating on slopes can be hazardous and cause loss of control and roll-overs.

10° Max.

- Do not operate on slopes over 10 degrees.
- Avoid sudden turns or rapid speed changes.
- Reduce speed and use extreme caution on slopes.
- Avoid turning down slopes; if possible turn up slopes.
- If machine stops forward motion on a slope, stop the blades and drive slowly off the slope.

**Water, retaining walls and drop-off hazards**  
Wheels dropping over edges may result in serious injury, death or drowning.

- Do NOT operate down slope towards or near water, retaining walls or drop-offs.
- Give yourself a minimum of two mower widths of clearance around these hazards.

**⚠ WARNING**

**Fire hazard**  
Gasoline is flammable. Yard debris is combustible.

- Allow engine to cool for at least 3 minutes before refueling.
- Keep unit cleaned of debris.
- This equipment may create sparks that can start fires around dry vegetation. A spark arrester may be required. Contact local fire agencies for regulations relating to fire prevention requirements.

**Avoid serious injury or death**  
Read the operator's manual before using this product.

- Do NOT operate this machine unless you are trained.
- Know the location and function of all controls.
- Keep safety devices (guards, shields, switches, etc.) in place and working.
- Remove objects that could be thrown by the blade.
- Be sure blade(s) and engine are stopped before placing hands or feet near blade(s).
- When leaving machine, shut off, remove key, and set parking brake.

CAN ICEB-2/NMB-2 5105564 B

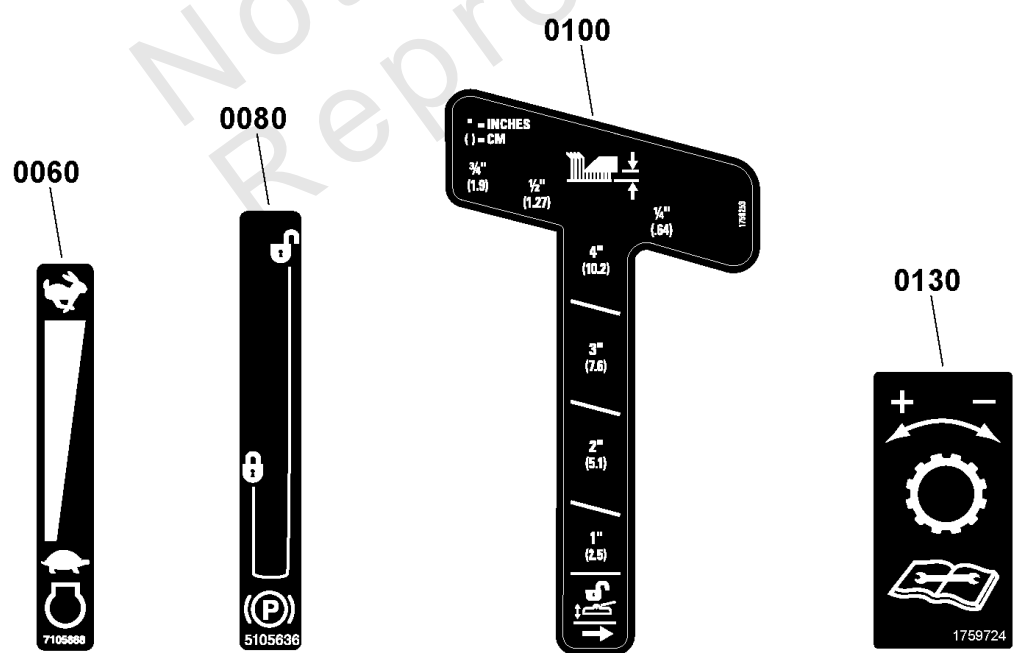

**⚠ DANGER**

**Amputation and thrown objects hazard**

- Keep hands and feet away from deck.
- Do not operate mower unless discharge chute or entire grass catcher is in its proper place.

7121085

**0145**

**HYDRAULIC OIL**

---

**USE SAE 20W-50 MOTOR OIL**

5100857

**0140**

**Belts & Blades**

Transmission Drive Belt	
Rear - Fixed Frame	84006539
Rear - Suspension	84006991
48" Mower	
Deck Drive Belt	84007231
Mower Blade	1759035YP
52" Mower	
Deck Drive Belt	84006548
Mower Blade	1756152AYP
61" Mower	
Deck Drive Belt	84006541
Mower Blade	5104045YP

8010004

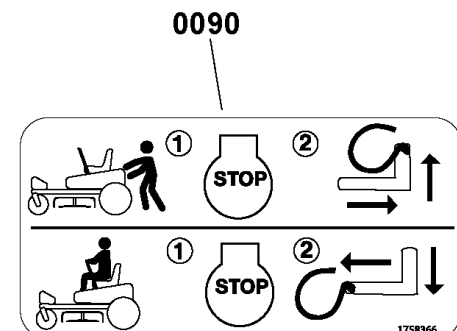

## ***Decals Group - Safety & Operation***

<b>REF NO</b>	<b>PART NO</b>	<b>QTY</b>	<b>DESCRIPTION</b>
0060	7105868YP	1	DECAL, ENGINE SPEED
0070	84003344	1	DECAL, MAIN, SAFETY
0080	84007063	1	DECAL, Parking Brake
0090	1758366YP	2	DECAL, Tow Release
0100	84007064	1	DECAL, Height of Cut
0130	1759724YP	2	DECAL, Tracking Adjustment - ZT
0140	84007624	1	DECAL, Service Parts
0145	84002270	1	DECAL, Oil
0210	7101665YP	2	DECAL, DANGER

Not For Reproduction

# Electrical Group

Note: Unless noted otherwise, use the standard torque specifications

Mfg. No: 2691817-00

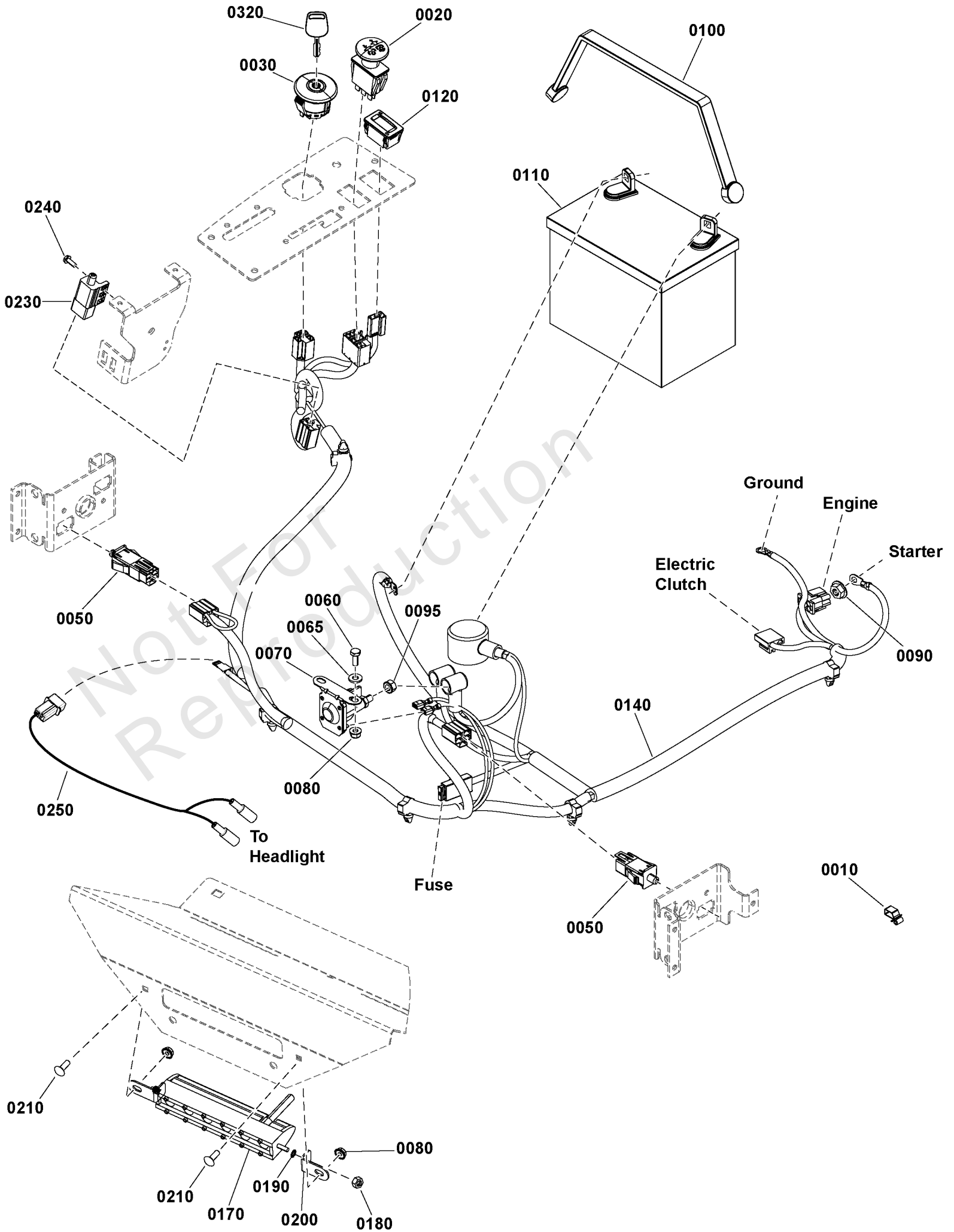



## Electrical Group

REF NO	PART NO	QTY	DESCRIPTION
0010	2172434SM	3	CLIP- WIRE DIA .390
0020	1722887SM	1	SWITCH-PTO PUSH
0030	7106169YP	1	SWITCH, IGNITION, DEL
0050	7022886YP	2	SWITCH, DP NO/NC SNAP
0060	703338	2	BOLT,1/4-20X5/8
0065	84007033	2	WASHER
0070	772333	1	SOLENOID, Starter
0080	5025391	4	NUT, 1/4-20 Hex Nylock Flange
0090	703061	1	NUT, HEX KEPS, 1/4-20
0095	2860750SM	2	NUT-HEX KEPS 5/16-24
0100	1722009SM	1	STRAP, Rubber, 13"
0110	-----	1	BATTERY, 12 VOLT, 230 CCA
0120	1731185SM	1	METER-HOUR DIGITAL NO
0140	84006894	1	HARNESS, WIRING
0170	84006903	1	HEADLIGHT ASSEMBLY
0180	84007034	2	NUT, Hex, M5X.8MM, Nylon Insert
0190	84007035	2	WASHER, 5MM, Star
0200	84007036	2	BRACKET, L Headlight Mount
0210	703575	2	BOLT, 1/4-20X.750, SQ
0230	1717050SM	1	SWITCH-PUSH BUTT
0240	704060	2	SCREW,HEX, #10-24X.5
0250	84006895	1	HARNESS, Headlight Jumper
0320	7106170YP	1	KEY, Ignition Switch, Pack of 2, NA/AU

# Electrical Schematic - Charging Circuit - B&S 44C777 & 44T977

Note: Unless noted otherwise, use the standard torque specifications

Mfg. No: 2691817-00

## 80097605 MAIN WIRE HARNESS - BRIGGS & STRATTON 44C777 & 44T977 ENGINES

80097605A

(If internal schematic of the switch is not shown, the image of the switch represents the back view of the connector as it is connected to the switch.)

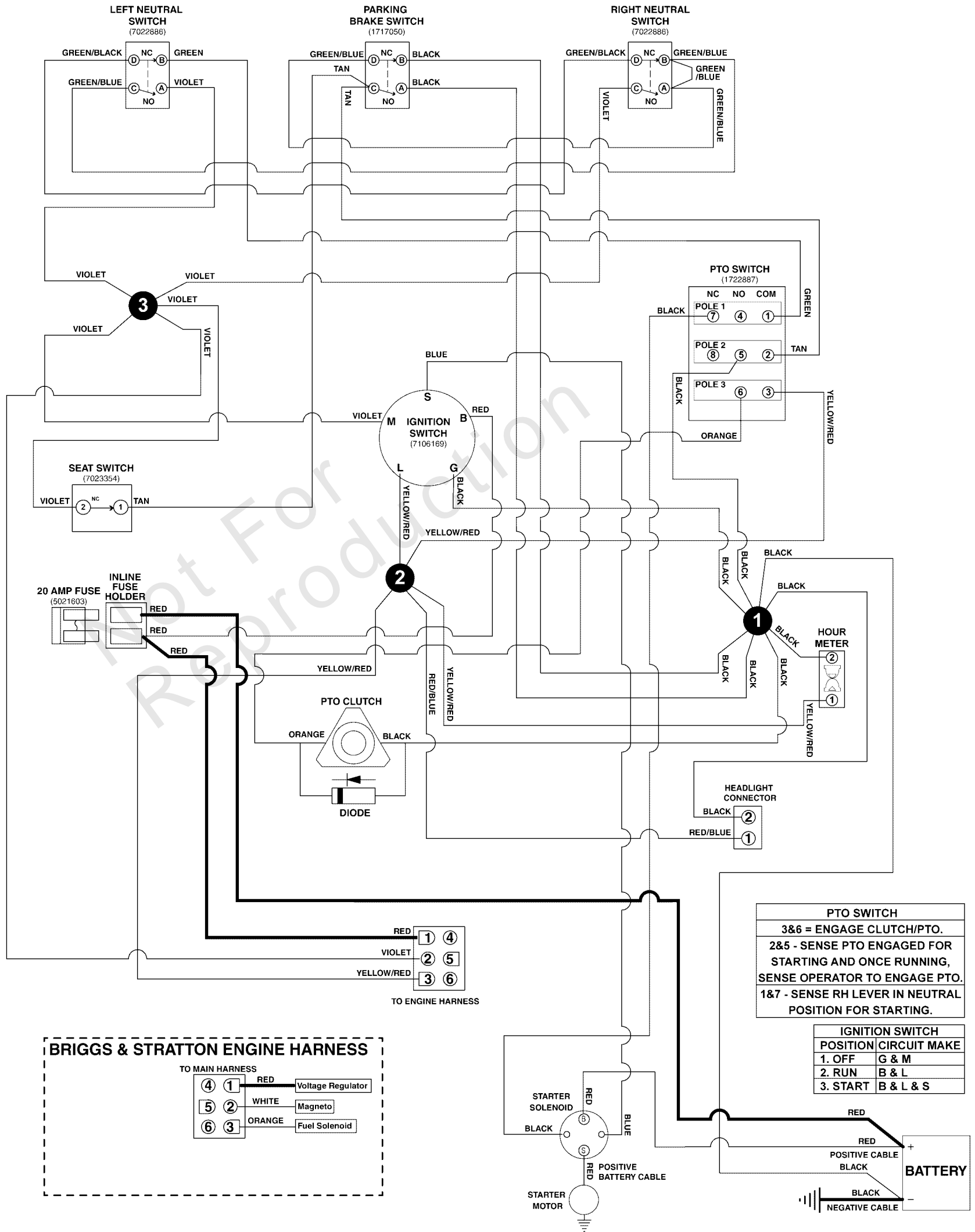

## Electrical Schematic - Charging Circuit - B&S 44C777 & 44T977

REF NO	PART NO	QTY	DESCRIPTION
80097605	84006894	1	HARNESS, WIRING
7022886	7022886YP	2	SWITCH, DP NO/NC SNAP
1717050	1717050SM	1	SWITCH-PUSH BUTT
1722887	1722887SM	1	SWITCH-PTO PUSH
7106169	7106169YP	1	SWITCH, IGNITION, DEL
7023354	7023354YP	1	SWITCH, SEAT
5021603	5021603SM	1	FUSE, ATO, 20 AMP

Not For Reproduction

# Electrical Schematic - Cranking Circuit - B&S 44C777 & 44T977

Note: Unless noted otherwise, use the standard torque specifications

Mfg. No: 2691817-00

## 80097605 MAIN WIRE HARNESS - BRIGGS & STRATTON 44C777 & 44T977 ENGINES

80097605A

(If internal schematic of the switch is not shown, the image of the switch represents the back view of the connector as it is connected to the switch.)

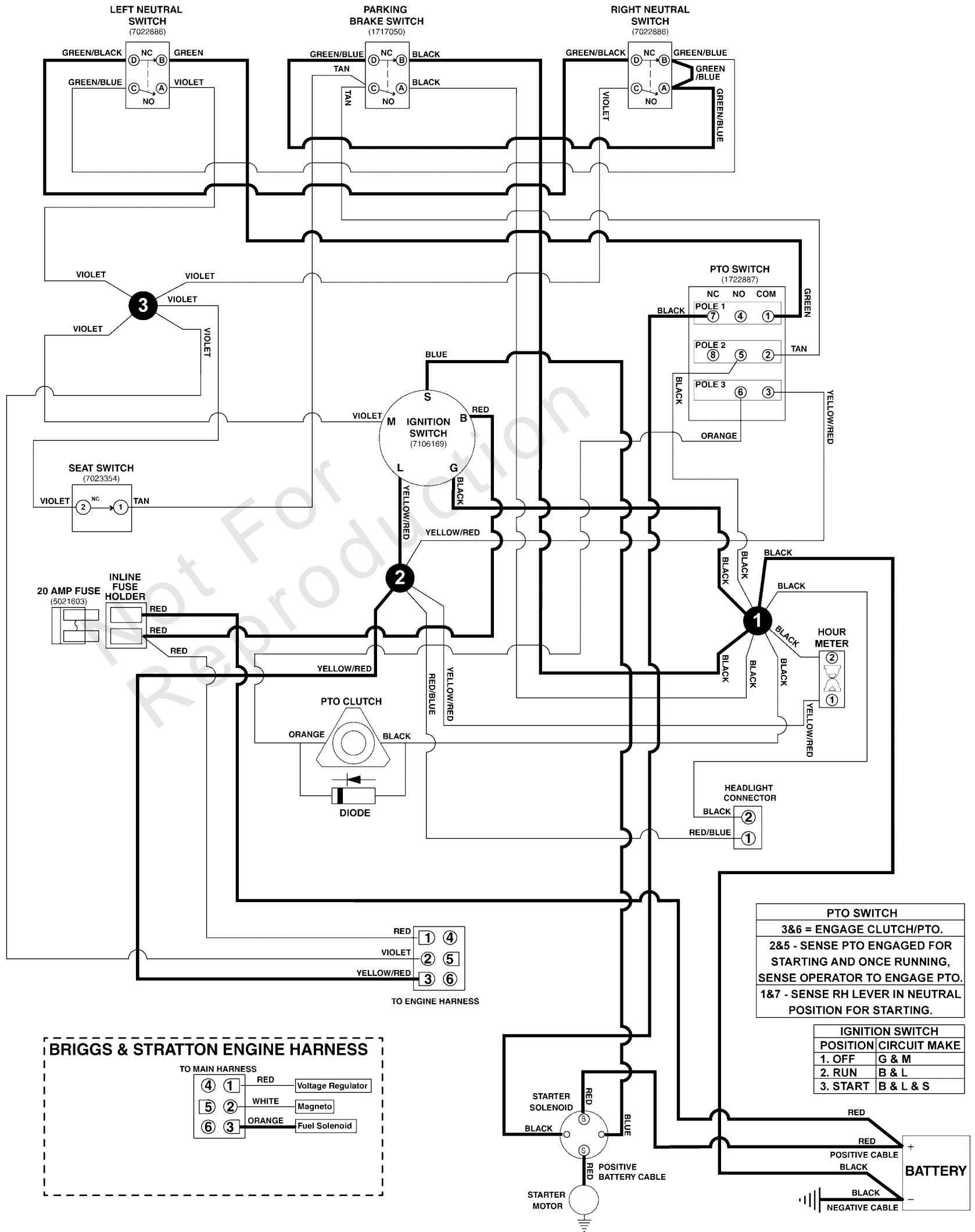

## Electrical Schematic - Cranking Circuit - B&S 44C777 & 44T977

REF NO	PART NO	QTY	DESCRIPTION
80097605	84006894	1	HARNESS, WIRING
7022886	7022886YP	2	SWITCH, DP NO/NC SNAP
1717050	1717050SM	1	SWITCH-PUSH BUTT
1722887	1722887SM	1	SWITCH-PTO PUSH
7106169	7106169YP	1	SWITCH, IGNITION, DEL
7023354	7023354YP	1	SWITCH, SEAT
5021603	5021603SM	1	FUSE, ATO, 20 AMP

Not For Reproduction

# Electrical Schematic - Ignition Grounding Circuit/Op. Pres. - B&S 44C777 & 44T977

Note: Unless noted otherwise, use the standard torque specifications

Mfg. No: 2691817-00

## 80097605 MAIN WIRE HARNESS - BRIGGS & STRATTON 44C777 & 44T977 ENGINES

80097605A

(If internal schematic of the switch is not shown, the image of the switch represents the back view of the connector as it is connected to the switch.)

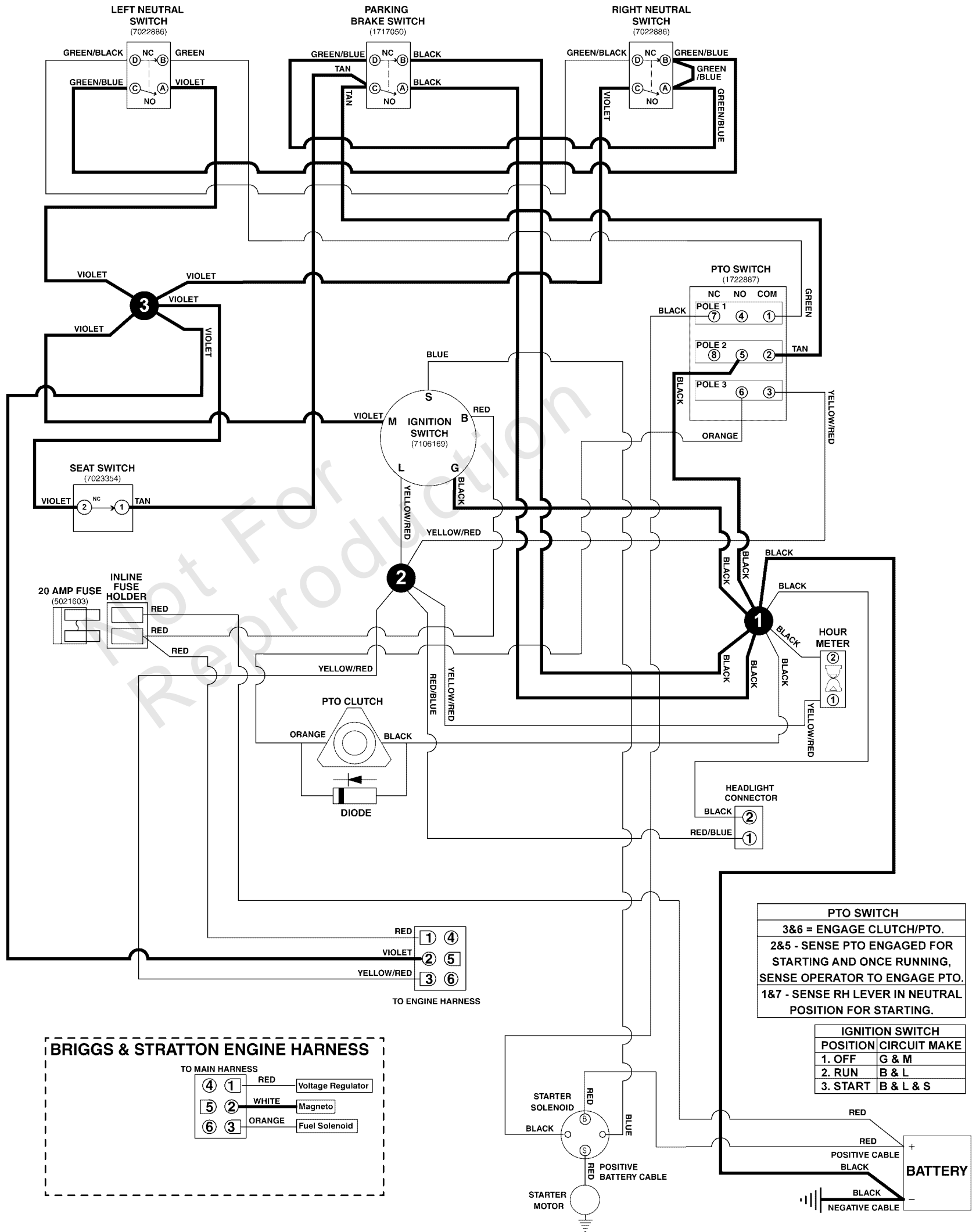

**Electrical Schematic - Ignition Grounding Circuit/Op. Pres. - B&S 44C777 & 44T977**

REF NO	PART NO	QTY	DESCRIPTION
80097605	84006894	1	HARNES, WIRING
7022886	7022886YP	2	SWITCH, DP NO/NC SNAP
1717050	1717050SM	1	SWITCH-PUSH BUTT
1722887	1722887SM	1	SWITCH-PTO PUSH
7106169	7106169YP	1	SWITCH, IGNITION, DEL
7023354	7023354YP	1	SWITCH, SEAT
5021603	5021603SM	1	FUSE, ATO, 20 AMP

Not For Reproduction

# Electrical Schematic - PTO Clutch Circuit - B&S 44C777 & 44T977

Note: Unless noted otherwise, use the standard torque specifications

Mfg. No: 2691817-00

## 80097605 MAIN WIRE HARNESS - BRIGGS & STRATTON 44C777 & 44T977 ENGINES

80097605A

(If internal schematic of the switch is not shown, the image of the switch represents the back view of the connector as it is connected to the switch.)

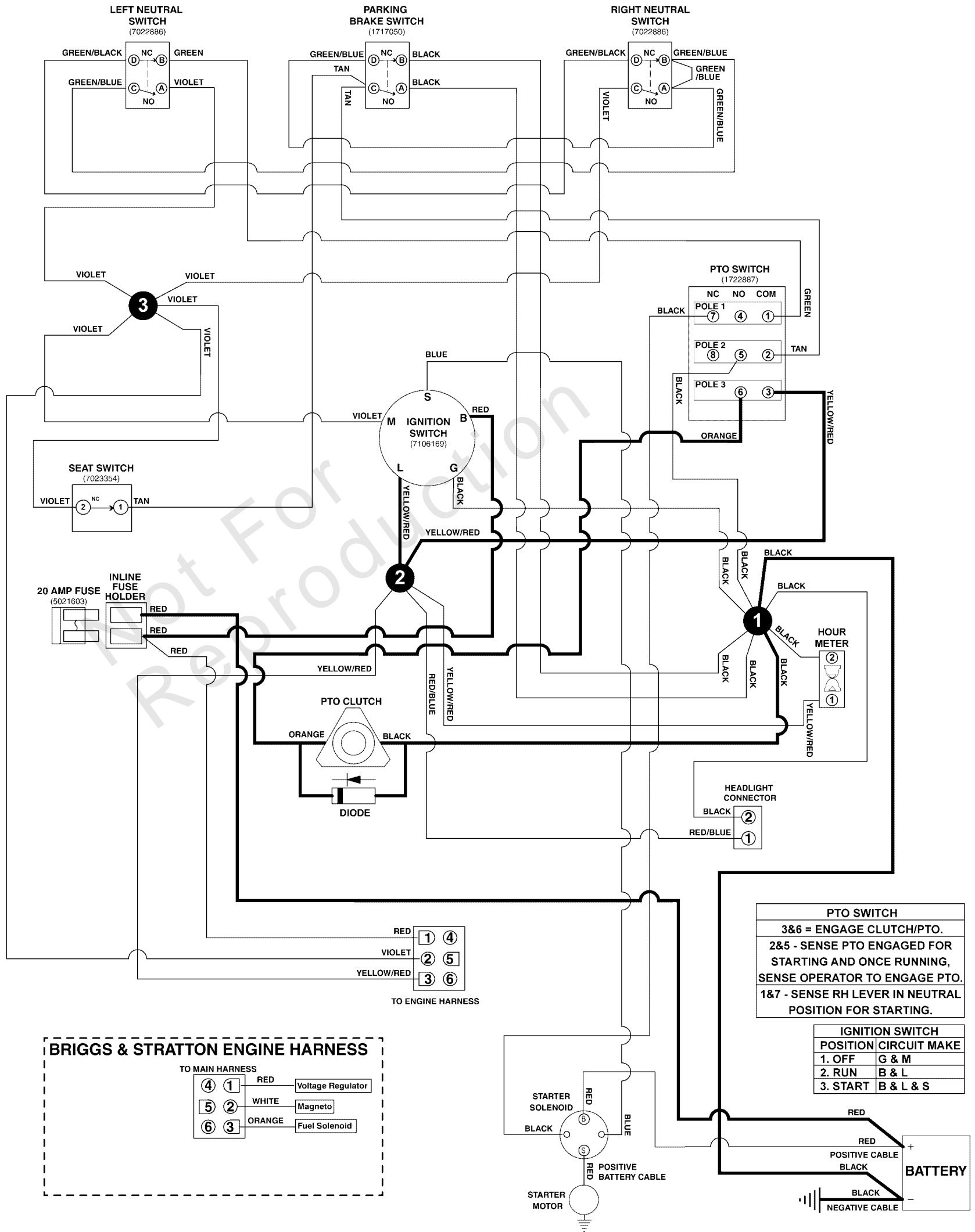



## Electrical Schematic - PTO Clutch Circuit - B&S 44C777 & 44T977

REF NO	PART NO	QTY	DESCRIPTION
80097605	84006894	1	HARNES, WIRING
7022886	7022886YP	2	SWITCH, DP NO/NC SNAP
1717050	1717050SM	1	SWITCH-PUSH BUTT
1722887	1722887SM	1	SWITCH-PTO PUSH
7106169	7106169YP	1	SWITCH, IGNITION, DEL
7023354	7023354YP	1	SWITCH, SEAT
5021603	5021603SM	1	FUSE, ATO, 20 AMP

Not For Reproduction

# Engine Group

Note: Unless noted otherwise, use the standard torque specifications

Mfg. No: 2691817-00

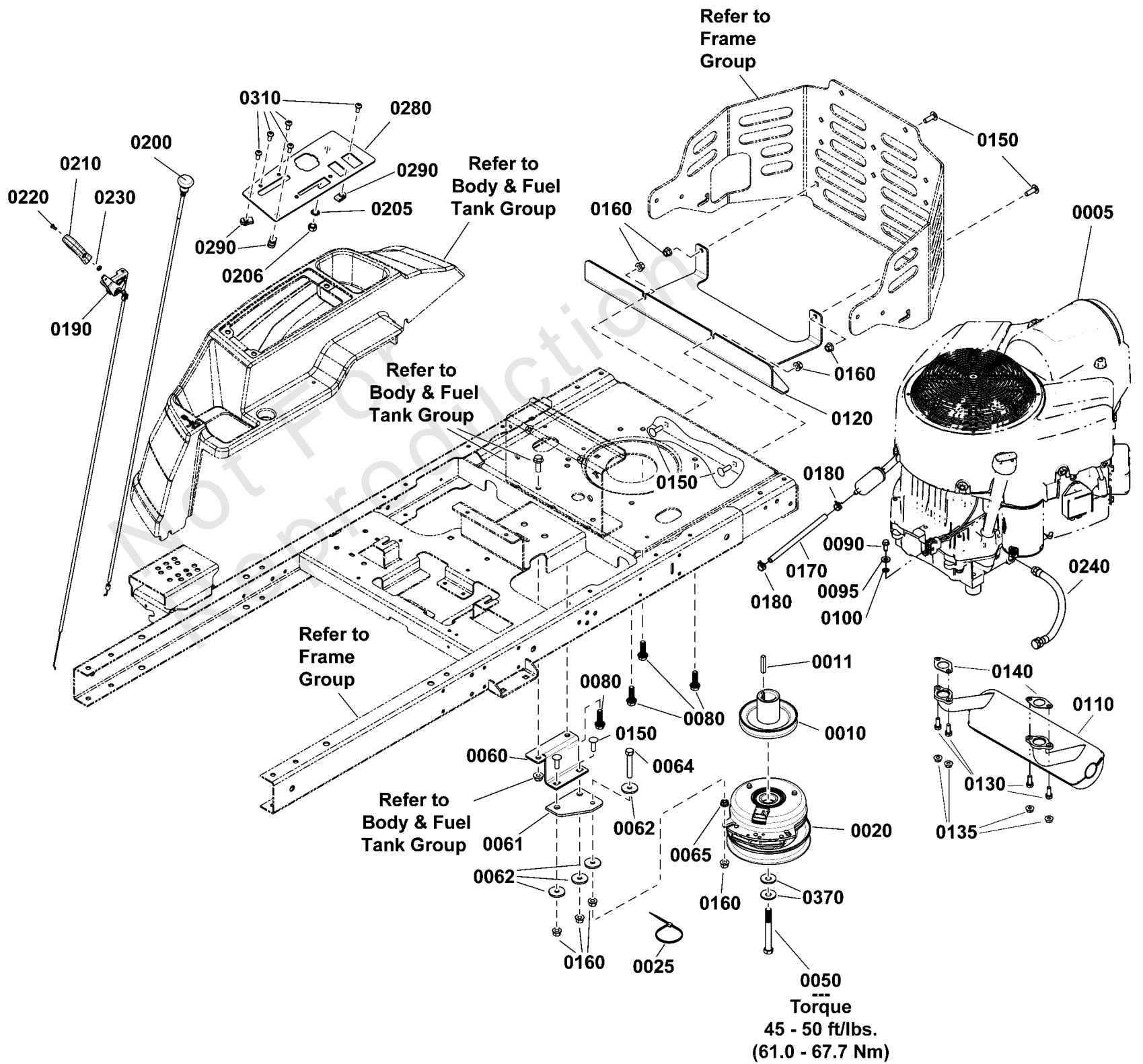

## Engine Group

REF NO	PART NO	QTY	DESCRIPTION
0005	44T977-0005-G1	1	* ENGINE, 25HP B&S COMM TURF, 1-1/8 X 4.29 -( Engine Model: 44N777-0005-G1 )
0010	84007555	1	PULLEY, CRANKSHAFT
0011	5022726YP	1	KEY 1/4 SQ X 1 1/2
0020	84006960	1	CLUTCH
0025	5021030SM	1	TIE WRAP, 5-1/2" LONG
0050	84007266	1	BOLT
0060	84007267	1	BRACKET
0061	84007268	1	PAD
0062	5044617SM	4	WASHER, .34 X 1.25 X
0064	5025055X18YP	1	BOLT, 5/16-18 X 2-1/4
0065	5025127SM	1	NUT, 5/16-18 HEX SERR
0080	2828635SM	4	SCREW-HEX WSHR HD TAP
0090	703054	1	SCREW, 1/4-20X0.625
0095	22473GS	1	FLAT WASHER, M6 - 1/4"
0100	1921880SM	1	LOCKWASHER-EXTERNALTO
0110	1758350YP	1	MUFFLER
0120	84006924	1	HEAT SHIELD
0130	690341	4	SCREW -( Refer to Note: ** )
0135	690941	4	NUT -( Refer to Note: *** )
0140	690970	2	GASKET, Exhaust
0150	703800	6	BOLT, CRRG, 5/16-18X1
0160	703115	8	NUT
0170	5050831X11YP	1	HOSE, 1/4" FUEL, 11.00"
0180	93807	2	CLAMP, Hose
0190	1759205YP	1	CONTROL-THROTTLE
0200	5100184SM	1	CABLE, CHOKE CONTROL,
0205	703864	1	WASHER, EXT, 3/8
0206	703895	1	NUT, HEX, 3/8-24
0210	1739312YP	1	KNOB, THROTTLE
0220	797483	1	SCREW
0230	703460	1	NUT, Hex #8-32
0240	1726498SM	1	HOSE-OIL DRAIN .375ID
0280	84006920	1	PANEL, CONTROL
0290	5022665SM	3	BODY CLIP, 1/4-20 X 1
0310	703953	5	SCREW, 1/4-20X5/8
0370	5025585YP	2	BELLEVILLE WASHER

### Footnotes:

Note:\*\* If your engine has muffler studs

Note:\*\* If your engine does not have muffler studs

Note:\* See your local Briggs & Stratton distributor for parts & service.

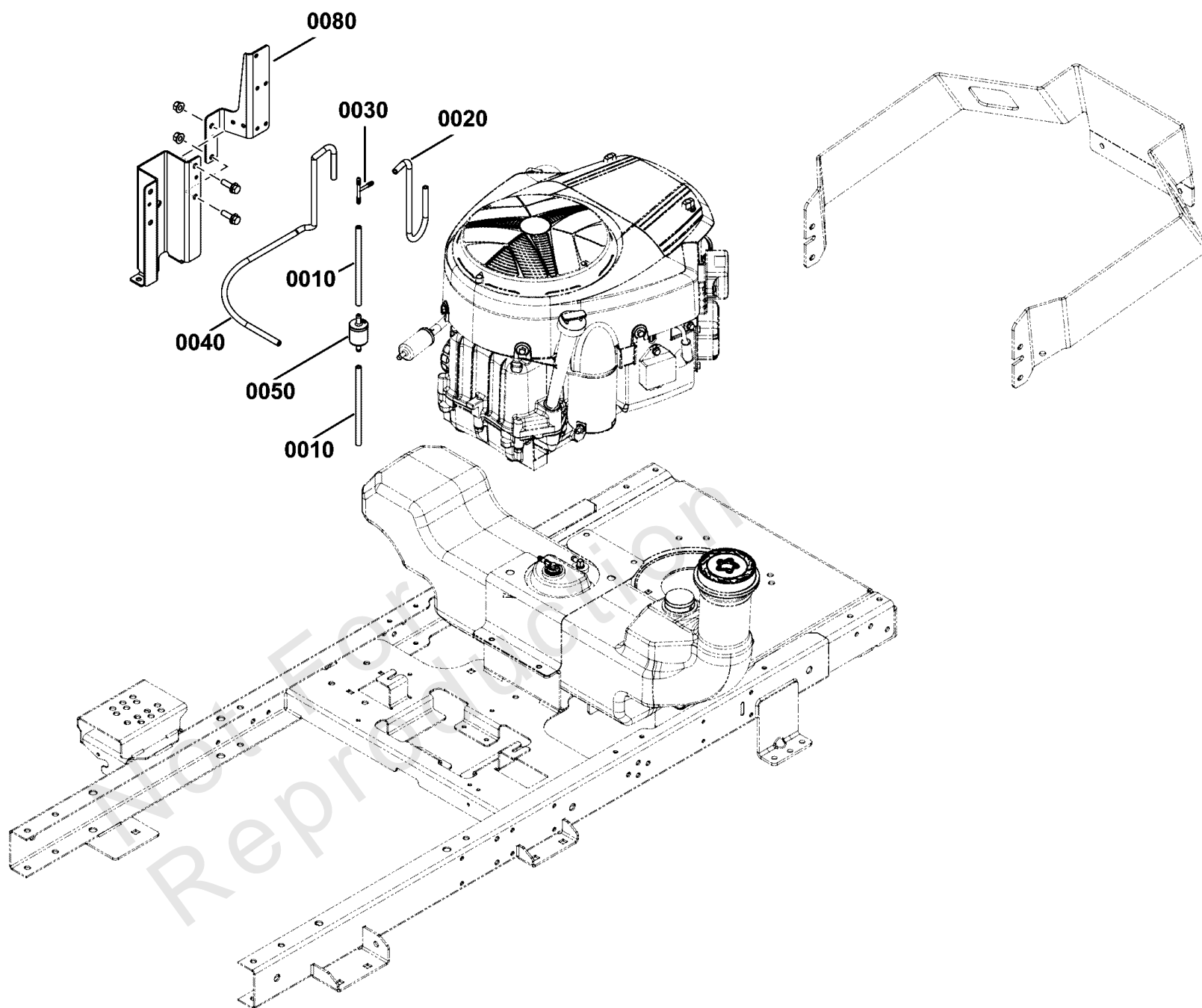

## EVAP Group

REF NO	PART NO	QTY	DESCRIPTION
0010	7700552X6YP	2	HOSE-VAPOR
0020	7700552X12YP	1	HOSE, VAPOR,5MM ID,12
0030	5103062YP	1	FITTING, 3/16" TEE, B
0040	7700552X26YP	1	HOSE, Vapor, 5 MM ID, 26.00 LG
0050	84001895	1	FILTER, Fuel
0070	5021030SM	5	TIE WRAP, 5-1/2" LONG -(Not Illustrated)
0080	1760538AYP	1	BRACKET

Not For Reproduction

# Frame Group

Note: Unless noted otherwise, use the standard torque specifications

Mfg. No: 2691817-00

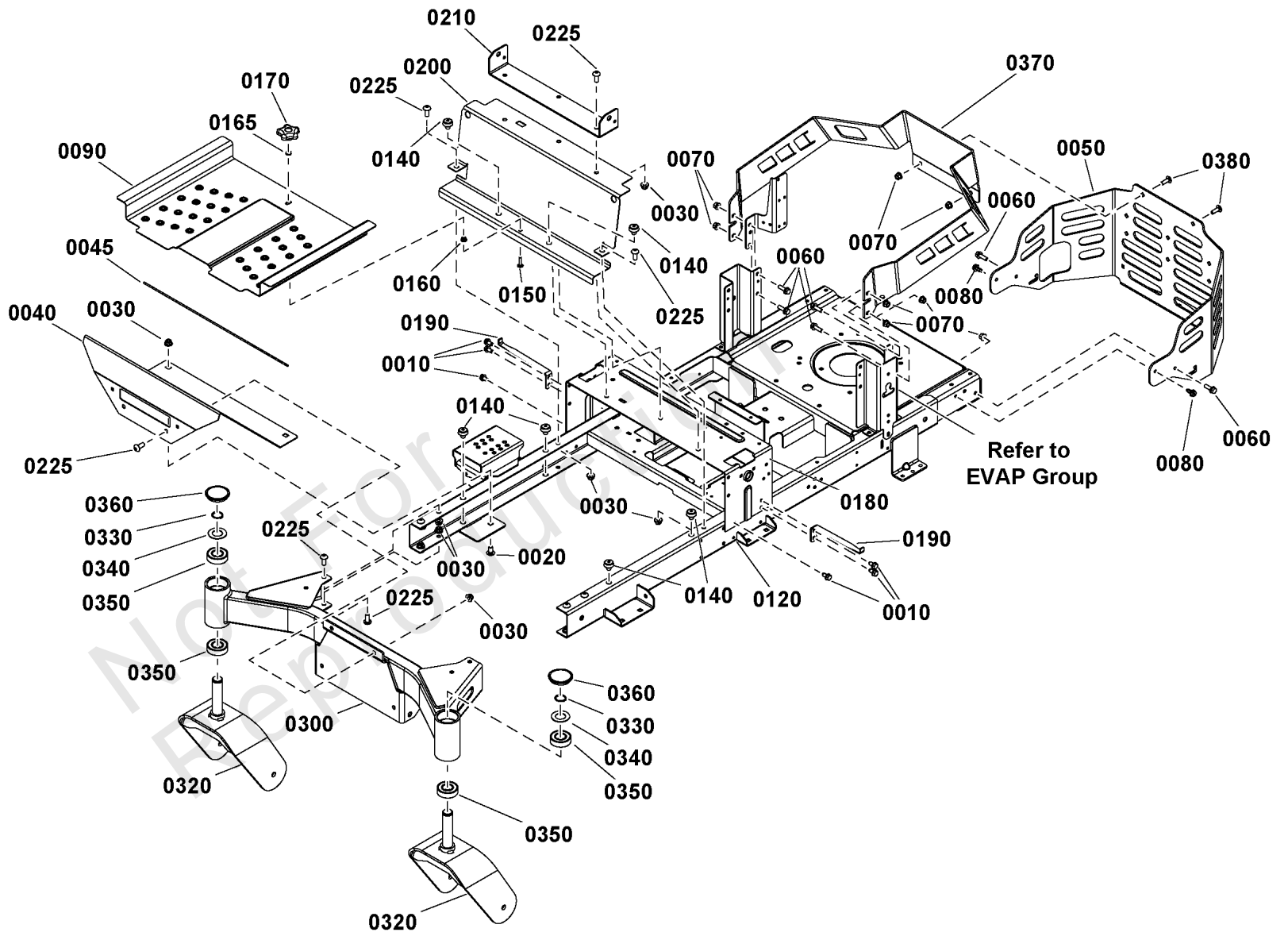

## Frame Group

REF NO	PART NO	QTY	DESCRIPTION
0010	703949	6	SCREW, 5/16-18.625
0020	703448	2	BOLT, 3/8-16X.75 G5
0030	5025394SM	17	NUT, 3/8-16 HEX NYLOCK
0040	84006904	1	FOOT REST, XT
0045	5101011SM	1	SAFETY WALK, 8.00 X 1
0050	84006906	1	BUMPER, Rear, XT
0060	703410	6	BOLT,5/16-18X1
0070	5025392SM	8	NUT, Ny Lock Flange, 5/16-18
0080	84007040	2	SCREW. Hex, Washer, 5/16-18 x 3/4
0090	1757813DYP	1	PAN, Foot
0120	-----	1	FRAME -( Not a serviceable part )
0140	197546GS	6	MOUNT-VIBRATION
0150	7090496YP	1	RHSSNB, 1/4C X1 GR5 Z
0160	703233	1	NUT, 1/4-20, GR5
0165	15X143MA	1	NUT,25-20 HEX FLG CTR
0170	707785	1	KNOB
0180	84007041	1	CONTROL BRACKET
0190	1758240AYP	2	BRACKET, Fender
0200	1757796DYP	1	BRACKET, Brand
0210	84007042	1	PLATE. Seat Pivot
0225	84004627	15	CAPSCREW
0300	84007043	1	WELDMENT, Fixed Axle
0320	84006897	2	WELDMENT, Caster
0330	703993	2	RETAINER, EXT RING, 1
0340	703199	2	WASHER, 1
0350	1758354YP	4	BEARING
0360	5105524YP	2	CAP
0370	84006908	1	BRACKET, Fascia, Rear
0380	703800	2	BOLT, CRRG, 5/16-18X1

# Lift Group

Note: Unless noted otherwise, use the standard torque specifications

Mfg. No: 2691817-00

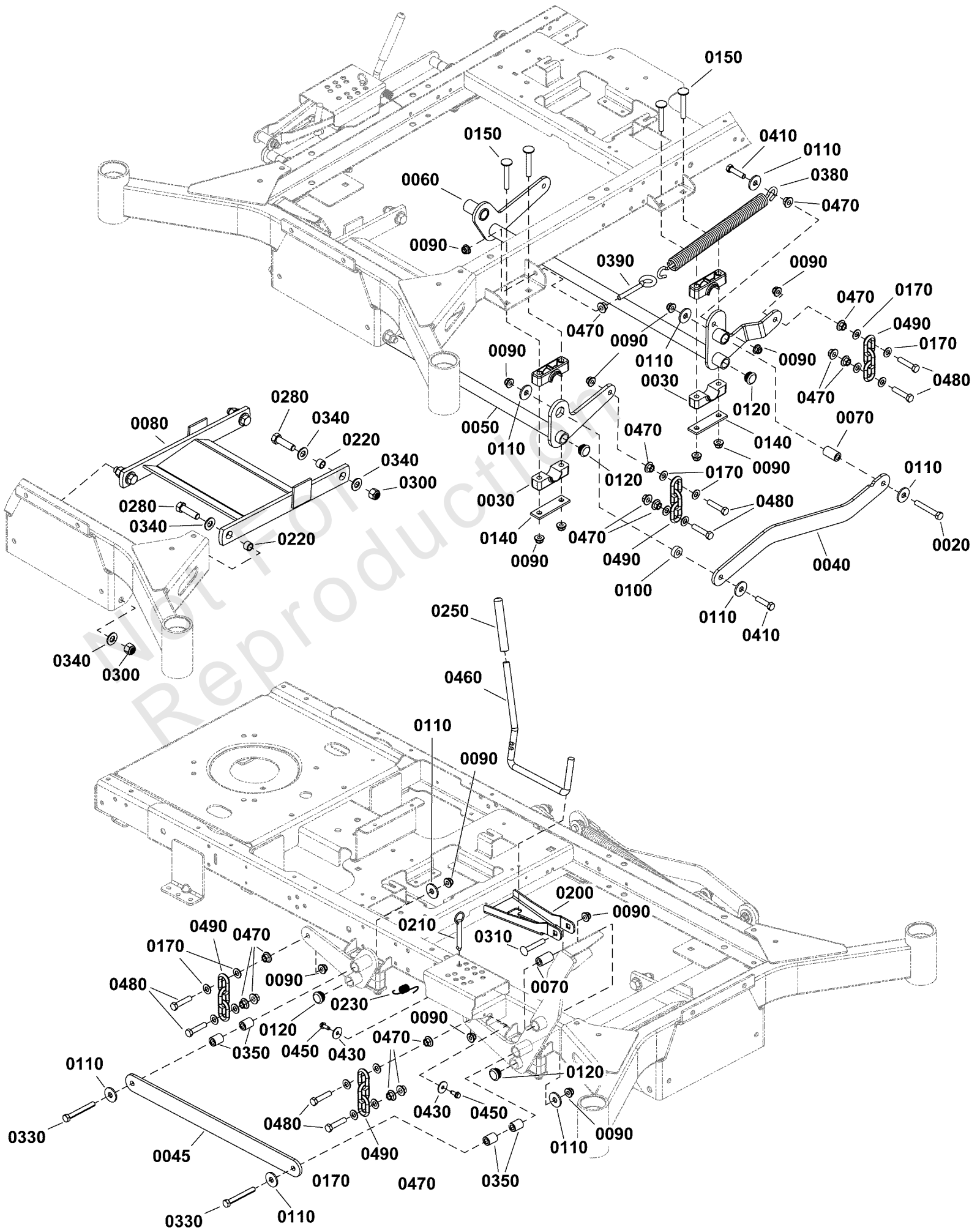



## Lift Group

REF NO	PART NO	QTY	DESCRIPTION
0020	5025013X20SM	1	BOLT, 3/8-16 X 2-1/2"
0030	5100634SM	8	PIVOT BLOCK, PLASTIC
0040	84006925	1	LINKAGE
0045	84006926	1	LINKAGE, Lift Assist, RH
0050	84006914	1	LIFTER
0060	84006915	1	SHAFT ASSEMBLY
0070	1756612YP	2	BUSHING, DIFF. LOCK
0080	84006928	1	BAR, PULLER
0090	5025394SM	19	NUT, 3/8-16 HEX NYLOCK
0100	1667811SM	1	SPACER
0110	1919384SM	9	WASHER-0.375(0.44IDX1
0120	84007739	4	PLUG
0140	5403925AYP	4	PLATE, Pivot
0150	1960615SM	8	BOLT-RD HD SQ NK 3/8
0170	5025156SM	16	WASHER, Flat, 3/8
0200	1758284AYP	1	BRACKET
0210	5103021YP	1	HITCH PIN, 3/8 X 2-1/
0220	5020870SM	4	INSERT, BEARING
0230	1758283YP	1	SPRING, EXTENSION
0250	5021880SM	1	GRIP, FOAM
0280	5025018X14SM	4	BOLT, 1/2-20 X 1-3/4" GD5 YZ
0300	5025098SM	4	NUT, 1/2-20 HEX NYLON
0310	7900009SM	1	RHSSNB, 3/8-16 X 2-1/
0330	5025013X24SM	2	BOLT, 3/8-16 X 3" GD5
0340	5025158SM	8	WASHER, 1/2" SAE
0350	1733068SM	4	SPACER-0.390IDX0.750O
0380	5023355SM	1	SPRING, DECK LIFT ASS
0390	5025429SM	1	EYEBOLT - 3/8-16
0410	703406	2	CAPSCREW,3/8-16X1.5
0430	5025288YP	2	WASHER, 1/4 FENDER
0450	703054	2	SCREW, 1/4-20X0.625
0460	5105717YP	1	ROD
0470	5025128SM	14	NUT, 3/8-16 HEX SERRA
0480	5025013X14SM	8	BOLT, 3/8-16 X 1-3/4"
0490	5050878X3SM	4	CHAIN, 5/16" GD30, 3

# Parking Brake Group

Note: Unless noted otherwise, use the standard torque specifications

Mfg. No: 2691817-00

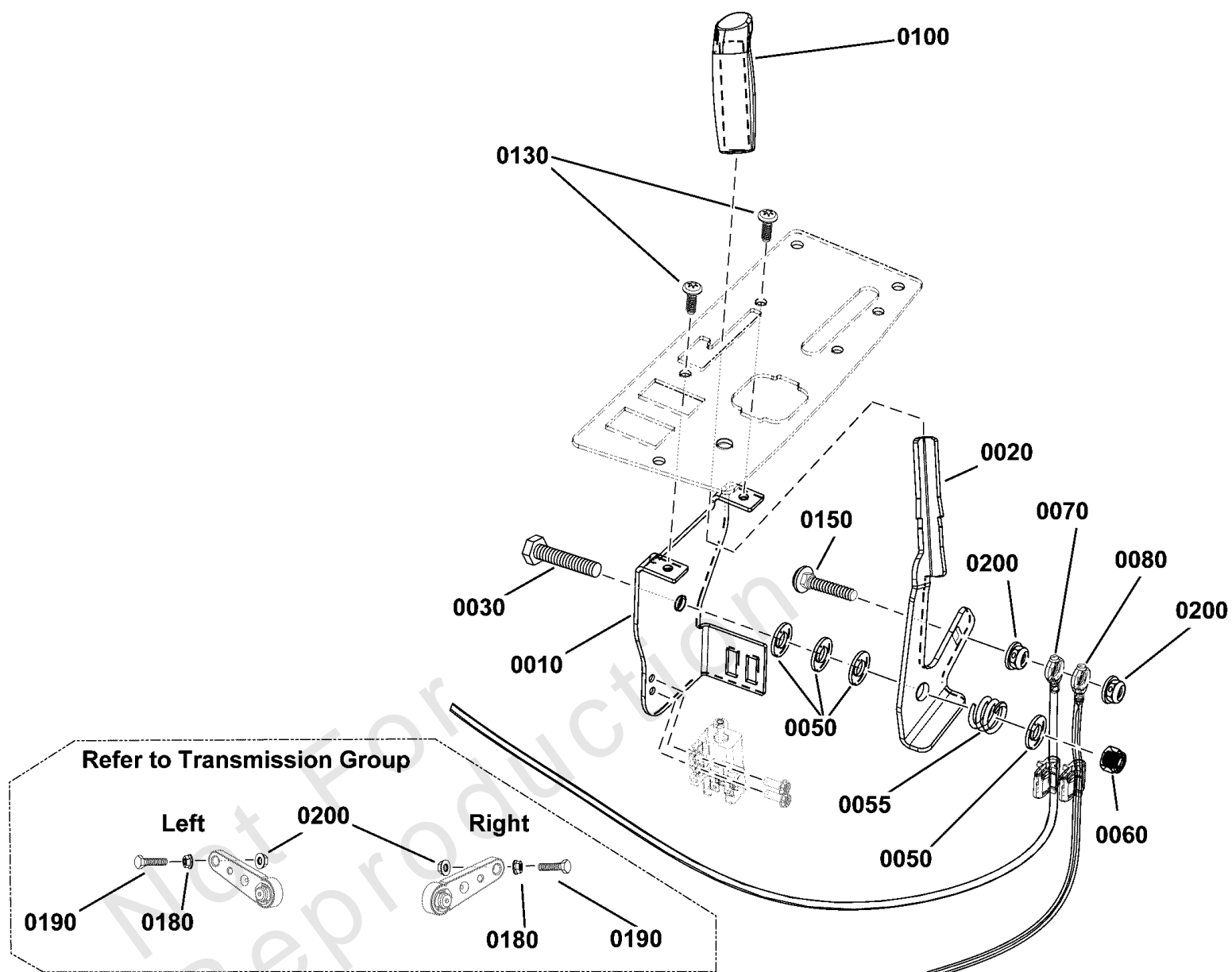

## Parking Brake Group

REF NO	PART NO	QTY	DESCRIPTION
0010	84006916	1	BRACKET
0020	84006917	1	LEVER
0030	703589	1	CAPSCREW, 3/8-16X2
0050	703878	1	WASHER, FLAT
0055	7028036YP	4	SPRING
0060	5025096SM	1	NUT, 3/8-16 HEX NYLON
0070	84006918	1	CABLE, BRAKE
0080	84006919	1	CABLE, BRAKE
0100	84001706	1	GRIP
0130	7090999SM	2	SCREW, Phillips Head, 1/4-20 X 5/8
0140	703586	2	TIE, SELF LOCKING -(Not Illustrated)
0150	703175	3	BOLT, RD SH SQ
0180	5025127SM	1	NUT, 5/16-18 HEX SERR
0190	5025011X12SM	2	BOLT, 5/16-18 X 1-1/2
0200	5025392SM	2	NUT, Ny Lock Flange, 5/16-18

Not For Reproduction

# Seat Group

Note: Unless noted otherwise, use the standard torque specifications

Mfg. No: 2691817-00

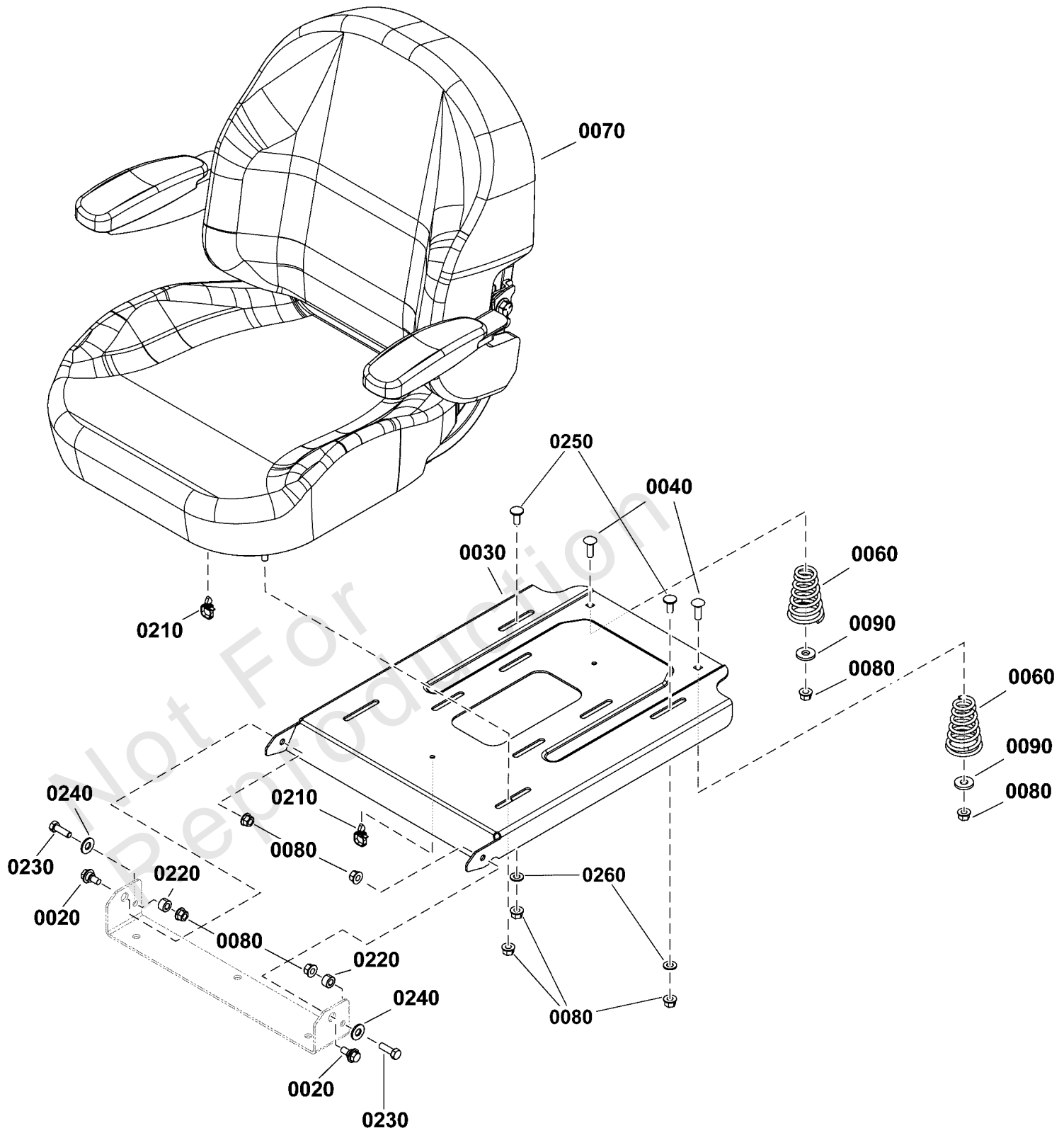

## Seat Group

REF NO	PART NO	QTY	DESCRIPTION
0020	1752802YP	2	BOLT, SHLDR, 5/16-18
0030	84001618	1	SLIDE, SEAT
0040	703483	2	BOLT,5/16-18X1.000,RO
0060	1717051SM	2	SPRING, Seat
0070	84006921	1	SEAT
0070-10	84006998	1	COVER, Cushion, Snapper
0070-20	84007000	1	COVER, Back, Snapper
0080	5025392SM	10	NUT, Ny Lock Flange, 5/16-18
0090	704128	2	WASHER
0210	708733	2	TIE, Cable 1/4
0220	5103767YP	2	SPACER, .33X.625X.360
0230	5025011X8SM	2	CAPSCREW, Hex Head, 5/16-18 X 1
0240	703878	2	WASHER, FLAT
0250	703350	2	WASHER
0260	703185	2	BOLT, Round Head, Short Square Neck

Not For Reproduction

# Transmission Group

Note: Unless noted otherwise, use the standard torque specifications

Mfg. No: 2691817-00

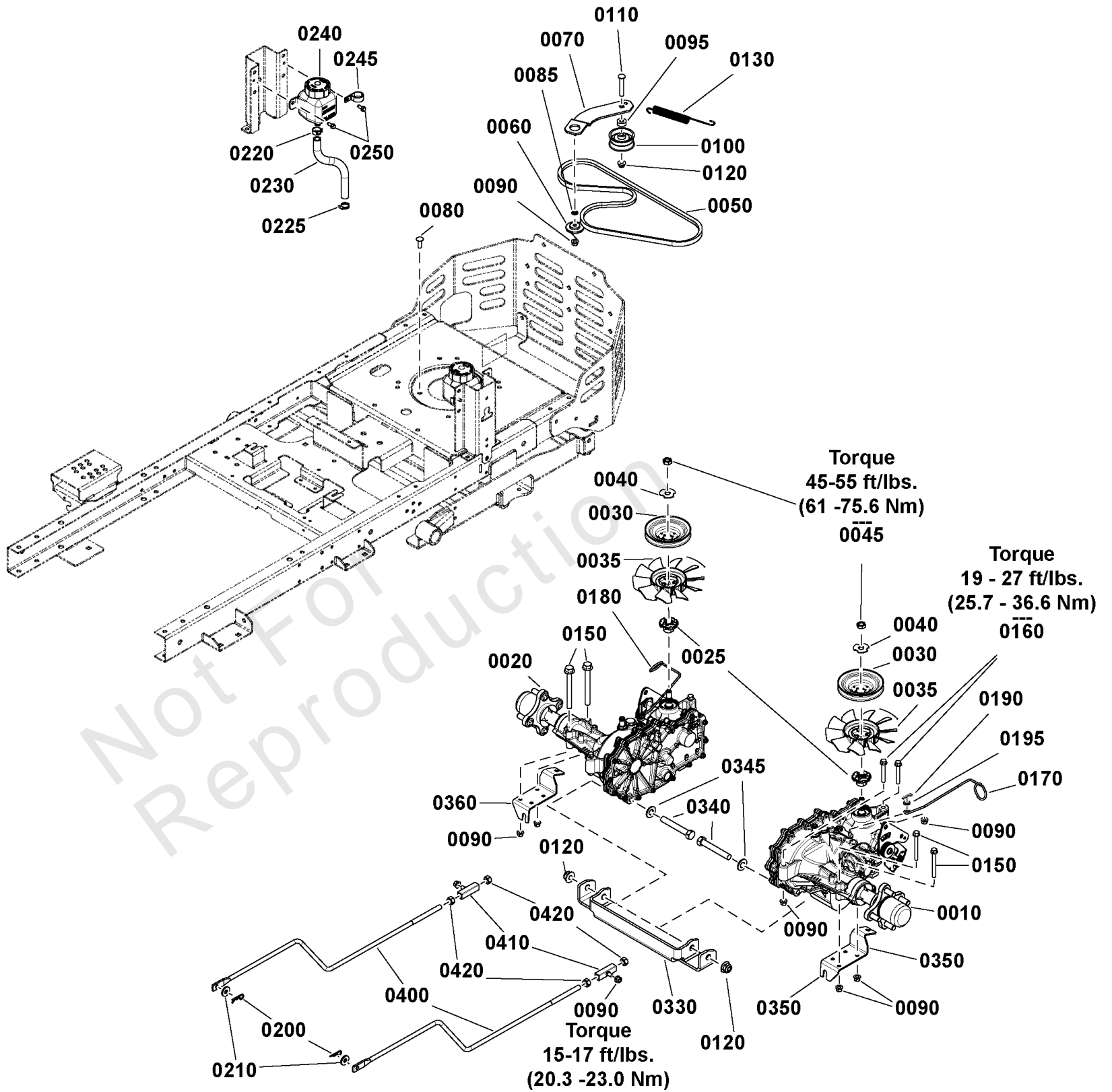

## Transmission Group

REF NO	PART NO	QTY	DESCRIPTION
0010	84006912	1	TRANSAXLE, ZT3100, ZL-GPEE-UL7B-2XLX
0020	84006913	1	TRANSAXLE, ZT3100, ZL-KPEE-UL7C-3XLX
0025	84003847	2	HUB
0030	1759447YP	2	PULLEY, Transmission
0035	84006902	2	FAN, 7"
0040	5102914YP	2	WASHER, ZT5400, SLOTT
0045	5102916YP	2	NUT, ZT5400
0050	84006539	1	BELT, 51.65"
0060	1727935SM	1	SPACER-PIVOT 0.330ID
0070	1758044AYP	1	ARM, Idler
0080	703800	1	BOLT, CRRG, 5/16-18X1
0085	703297	1	RETAINER, GR5, 5/16
0090	703115	11	NUT
0095	1667811SM	1	SPACER
0100	1668477SM	1	PULLEY, Idler, 2.25" OD, .378 ID
0110	1931355SM	1	BOLT, Carriage, 3/8 -16
0120	5025394SM	3	NUT, 3/8-16 HEX NYLOCK
0130	1758045YP	1	SPRING-EXTENSION
0150	707943	4	SCREW
0160	707944	4	SCREW, Washer Head, 5/16-18 X 2 1/4
0170	1759245YP	1	ROD, Release, LH
0180	1759246YP	1	ROD, Release, RH
0190	703430	2	PIN, 13X1.19
0195	5025154	2	WASHER, 1/4 SAE
0200	703300	2	PIN, 3/32 X 1.6
0210	704128	2	WASHER
0220	5025474SM	2	CLAMP - HOSE
0225	5021392SM	2	CLAMP, #6 HOSE, STAIN
0230	5050857X9P5YP	2	HOSE, 9.50
0240	5100473SM	2	RESERVOIR
0245	5021500SM	1	CLAMP, VINYL INSULATED, 1.00
0250	703054	4	SCREW, 1/4-20X0.625
0330	1759172AYP	1	SUPPORT
0340	5025013X20	2	BOLT, 3/8-16 X 2-1/2" GD5 CZ
0345	5025156SM	2	WASHER, Flat, 3/8
0350	84006958	1	BRACKET
0360	84006959	1	BRACKET
0400	84002180	2	CONTROL ROD, Transmission
0410	84002181	2	TRUNNION
0420	7090460SM	4	NUT, 7/16F, GR5, Hex

# Wheel & Tire Group

Note: Unless noted otherwise, use the standard torque specifications

Mfg. No: 2691817-00

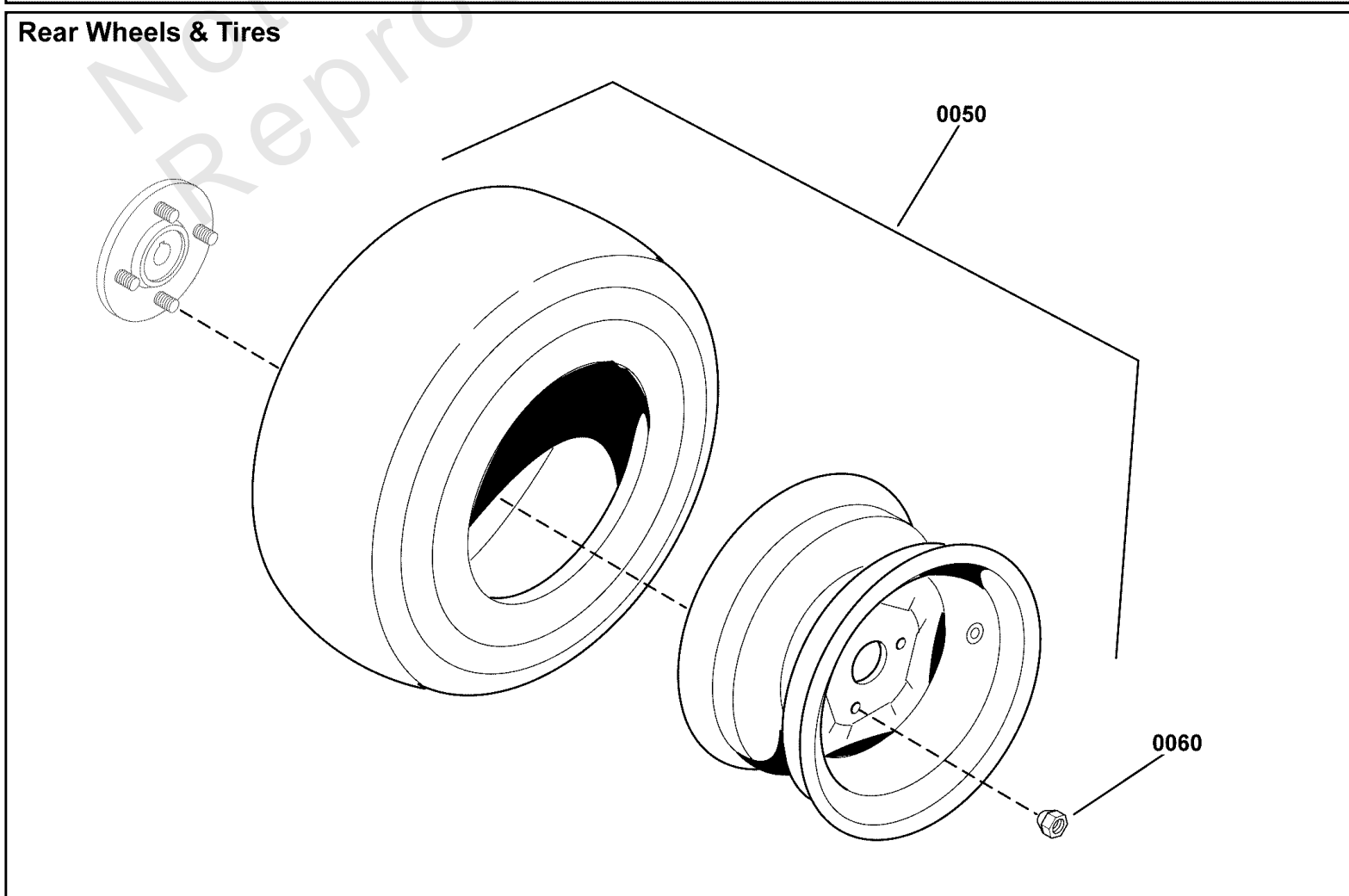
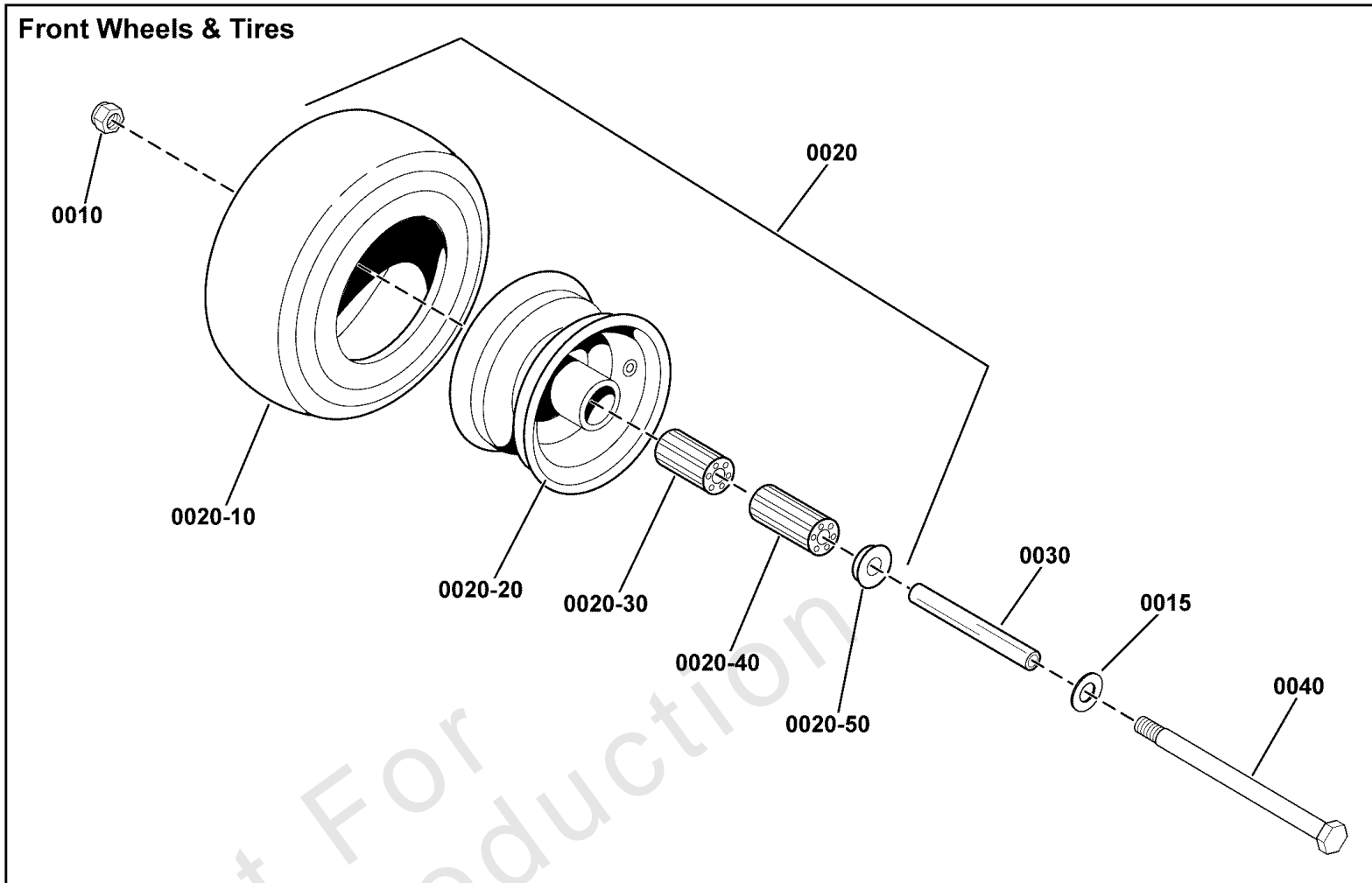



## Wheel & Tire Group

REF NO	PART NO	QTY	DESCRIPTION
0010	5025396SM	2	NUT, Hex Flange, 1/2-13
0015	5025158SM	2	WASHER, 1/2" SAE
0020	84006933	2	WHEEL ASSEMBLY, Front, Black
0020-10	84002535	2	TIRE, 13X650-6-4 PLY SMOOTH
0020-20	-----	2	RIM, 6" Dia. X 4.5" Bead Width -( Not a serviceable part )
0020-30	84002537	2	BEARING, OPEN GAGE ROLLER, 3/4" ID X 2.75"
0020-40	5021182SM	2	BEARING, Roller (1 per tire)
0020-50	5021043SM	2	RETAINER, Bearing
0030	84002029	2	CASTER AXLE SHAFT, .51"ID X .75"ODX 7.16
0040	5025017X72YP	2	BOLT, 1/2-13 X 9 GD5
0050	84006935	2	WHEEL ASSEMBLY
0060	5020601SM	8	NUT, 1/2-20, FOR WHEEL BOLT SILVER

Not For Reproduction

# Hardware Identification & Torque Specifications

Torque Specification Chart								
FOR STANDARD METRIC MACHINE HARDWARE (Tolerance ± 20%)								
Property Class	5.6		8.8		10.9		12.9	
	Class 5.6		Class 8.8		Class 10.9		Class 12.9	
Size Of Hardware	in/lbs	Nm.	in/lbs	Nm.	in/lbs	Nm.	in/lbs	Nm.
	ft/lbs		ft/lbs		ft/lbs		ft/lbs	
M3	5.88	.56	13.44	1.28	19.2	1.80	22.92	2.15
M4	13.44	1.28	30.72	2.90	43.44	4.10	52.56	4.95
M5	26.4	2.50	60.96	5.75	5.97	8.10	7.15	9.7
M6	44.64	4.3	7.3	9.9	10.3	14	12.1	16.5
M7	5.2	7.1	12.1	16.5	16.9	23	19.9	27
M8	7.7	10.5	17.7	24	25	34	29	40
M10	15	21	35	48	50	67	59	81
M12	26	36	61	83	86.2	117	103	140
M14	42	58	101	132	136	185	162	220
M16	64	88	147	200	210	285	250	340
M18	89	121	202	275	287	390	346	470
M20	126	171	290	390	405	550	486	660
M22	169	230	390	530	559	745	656	890
M24	217	295	497	375	708	960	840	1140
M27	320	435	733	995	1032	1400	1239	1680
M30	435	590	995	1350	1401	1900	1681	2280
M33	590	800	1349	1830	1902	2580	2278	3090
M36	759	1030	1740	2360	2441	3310	2935	3980
M39	988	1340	2249	3050	3163	4290	3798	5150

Torque Specification Chart						
FOR STANDARD MACHINE HARDWARE (Tolerance ± 20%)						
Hardware Grade	No Marks		SAE Grade 5		SAE Grade 8	
	SAE Grade 2		SAE Grade 5		SAE Grade 8	
Size Of Hardware	in/lbs	Nm.	in/lbs	Nm.	in/lbs	Nm.
	ft/lbs		ft/lbs		ft/lbs	
8-32	19	2.1	30	3.4	41	4.6
8-36	20	2.3	31	3.5	43	4.9
10-24	27	3.1	43	4.9	60	6.8
10-32	31	3.5	49	5.5	68	7.7
1/4-20	66	7.6	8	10.9	12	16.3
1/4-28	76	8.6	10	13.6	14	19.0
5/16-18	11	15.0	17	23.1	25	34.0
5/16-24	12	16.3	19	25.8	29	34.0
3/8-16	20	27.2	30	40.8	45	61.2
3/8-24	23	31.3	35	47.6	50	68.0
7/16-14	30	40.8	50	68.0	70	95.2
7/16-20	35	47.6	55	74.8	80	108.8
1/2-13	50	68.0	75	102.0	110	149.6
1/2-20	55	74.8	90	122.4	120	163.2
9/16-12	65	88.4	110	149.6	150	204.0
9/16-18	75	102.0	120	163.2	170	231.2
5/8-11	90	122.4	150	204.0	220	299.2
5/8-18	100	136	180	244.8	240	326.4
3/4-10	160	217.6	260	353.6	386	525.0
3/4-16	180	244.8	300	408.0	420	571.2
7/8-9	140	190.4	400	544.0	600	816.0
7/8-14	155	210.8	440	598.4	660	897.6
1-8	220	299.2	580	788.8	900	1,244.0
1-12	240	326.4	640	870.4	1,000	1,360.0

The guides and ruler furnished below are designed to help you select the appropriate hardware.



Nut, M8

Thread Diameter (mm)

Inside Diameter (in)      Threads per inch

Nut, 1/2-16

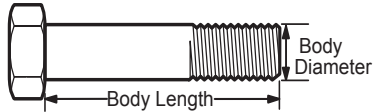

Screw, M8- 1.25 x 25

Thread Diameter (mm)      Distance between threads (mm)      Body Length (mm)

Body Diameter      Threads per inch      Body Length (in)

Screw, 1/2- 16 x 2



## Standard Hardware Sizing

When a washer or nut is identified as 1/2" (M8), this is the *Nominal size*, meaning the *inside diameter* is 1/2 inch (8mm metric thread diameter); if a second number is present it represents the *threads per inch* (distance between threads).

When bolt or capscrew is identified as 1/2 - 16 x 2" (M8 - 1.25 x 50), this means the *Nominal size*, or body diameter is 1/2 inch (8mm metric thread diameter), the second number, 16, represents the *threads per inch*, (*distance between threads*). The final number is the body length of the bolt or screw, 2 inches (50mm).

## NOTES

- These torque values are to be used for all hardware excluding: locknuts, self-tapping screws, thread forming screws, sheet metal screws and socket head setscrews.
- Recommended seating torque values for locknuts:
  - for prevailing torque locknuts - use 65% of grade 5 torques.
  - for flange whizlock nuts and screws - use 135% of grade 5 torques.
- Unless otherwise noted on assembly drawings, all torque values must meet this specification.

## Common Hardware Types

Hex Head Capscrew



Washer



Carriage Bolt



Hex Nut

## Wrench & Fastener Size Guide

1/4" Bolt or Nut Wrench—7/16"	5/16" Bolt or Nut Wrench—1/2"	3/8" Bolt or Nut Wrench—9/16"	7/16" Bolt or Nut Wrench (Bolt)—5/8" Wrench (Nut)—11/16"	1/2" Bolt or Nut Wrench—3/4"
M6 Bolt or Nut Wrench—10mm	M8 Bolt or Nut Wrench—13mm	M10 Bolt or Nut Wrench—17mm	M12 Bolt or Nut Wrench—19mm	M14 Bolt or Nut Wrench—22mm

