



Parts Manual

Mfg. No: 2691664-01
SPX2548, 48" Fabricated 25 HP SPX
Lawn Tractor 150 Series



1691319SM - Suitcase Weights, 33Lbs.

1690555SM - Weight, Rear Wheel (1 Each).....

1694921 - Snow Cab, Soft Side.....

1694922SM - Weight Carrier, Rear.....

1696092 - Dozer Blade, 42".....

1696750-00 - Turbo, 48" Fabricated Mower Deck.....

1696423-00 - Snowthrower, Single Stage, 42".....

1696909 - Grass Mulcher Kit, 48" Fabricated Mower Deck.....

1696750A-00 - Turbo, 48" Fabricated Mower Deck.....

1696092A-00 - Dozer Blade, 42".....

1697359A-00 - Catcher, Clean Sweep, Triple.....

1697376A-00 - Bagging Boot, Blade & Baffle, 48".....

Not For
Reproduction

Model Components	Page
48" (122cm) Mower Deck - Clutch & Support Group.	4
48" (122cm) Mower Deck - Height Adjustment Group.	6
48" (122cm) Mower Deck - Housing, Arbors & Blades Group.	8
Controls Group.	10
Decals Group.	12
Electrical Group.	14
Electrical Schematic -.	18
Electrical Schematic - Charging Circuit.	20
Electrical Schematic - Cranking Circuit.	22
Electrical Schematic - Headlight Circuit.	24
Electrical Schematic - Height of Cut.	26
Electrical Schematic - Hour Meter.	28
Electrical Schematic - Ignition Shutdown.	30
Electrical Schematic - PTO Clutch Circuit.	32
Engine Group.	34
Frame & Front Axle Group.	36
Front Axle Group.	38
Hood, Grille & Dash Group.	40
Lift Group - Manual.	42
Seat Deck & Fuel Tank Group.	44
Seat Group.	46
Steering Group.	48
Transmission Group.	50
Transmission SERVICE PARTS - Tuff Torq K46BP (1729588).	52
Wheels & Tires.	56
Torque Specification Chart.	58

48" (122cm) Mower Deck - Clutch & Support Group

Note: Unless noted otherwise, use the standard torque specifications

Mfg. No: 2691664-01

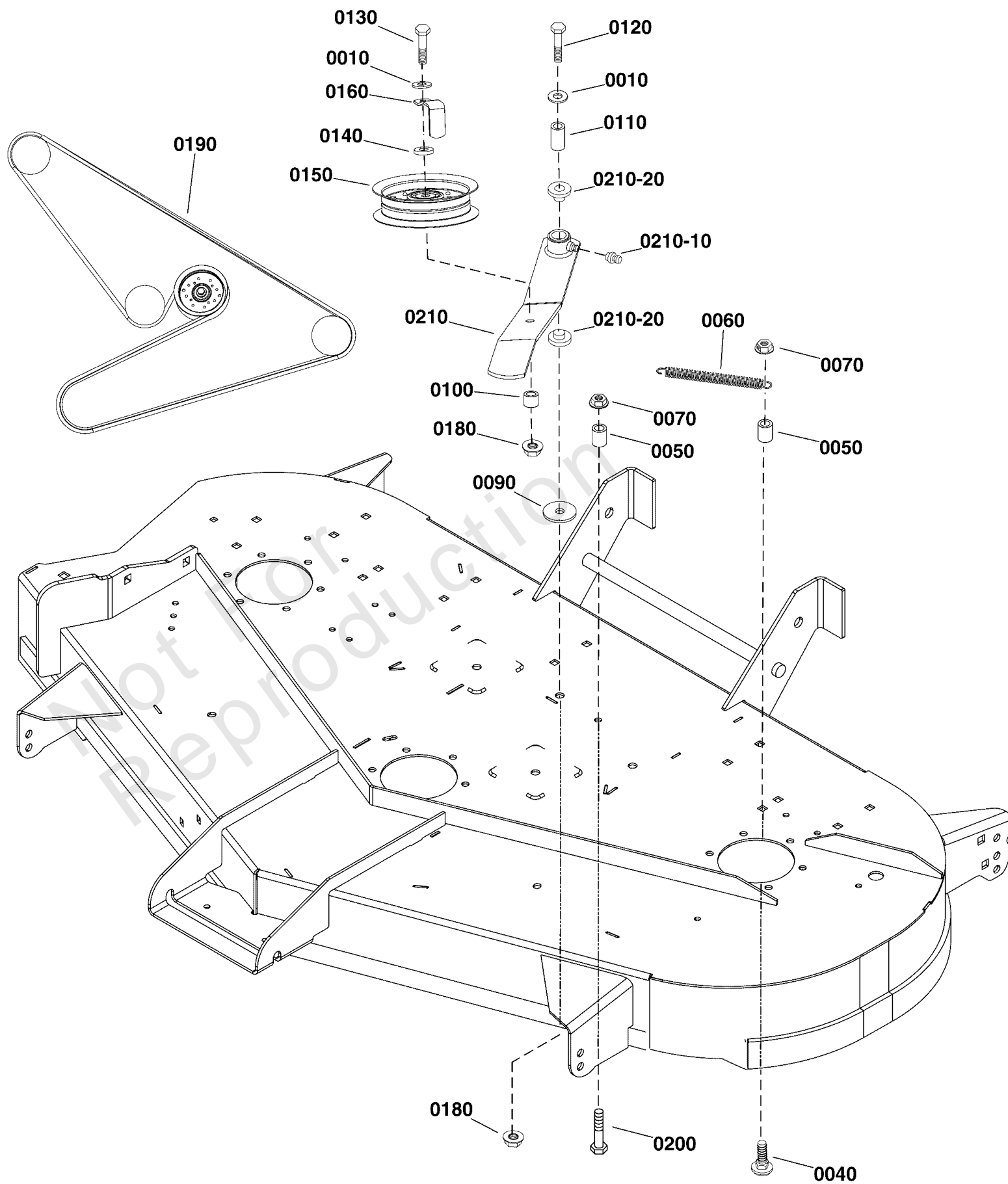

48" (122cm) Mower Deck - Clutch & Support Group

REF NO	PART NO	QTY	DESCRIPTION
0010	703878	2	WASHER, FLAT
0040	703296	1	BOLT, 5/16-18X1.5
0050	1710703SM	2	SPACER, 3/8 x 1/2 x 5/8
0060	1715435SM	1	SPRING, EXTENSION, 1.
0070	704001	2	NUT, 5/16-18
0090	703591	1	WASHER, .406X1.5X.12
0100	5101640YP	1	SPACER
0110	1674669SM	1	SPACER-0.39 IDX0.625O
0120	703589	1	CAPSCREW, 3/8-16X2
0130	703873	1	CAPSCREW,3/8-16X2.5
0140	703346	1	SPACER
0150	1757823YP	1	PULLEY-IDLER 4"
0160	1761267CJYP	1	GUARD, Belt
0180	703893	2	NUT, CNTR LCK, 3/8-16
0190	1761268YP	1	V-BELT, 118"
0200	703570	1	CAPSCREW, Hex Head, 5/16-18 x 1 1/4
0210	1761271YP	1	IDLER ARM ASSEMBLY -(Includes Ref. Nos. 0210-10 & 0210-20)
0210-10	703907	1	ZERK, FITTING, 1/4
0210-20	1676148SM	2	BUSHING-0.628IDX

48" (122cm) Mower Deck - Height Adjustment Group

Note: Unless noted otherwise, use the standard torque specifications

Mfg. No: 2691664-01

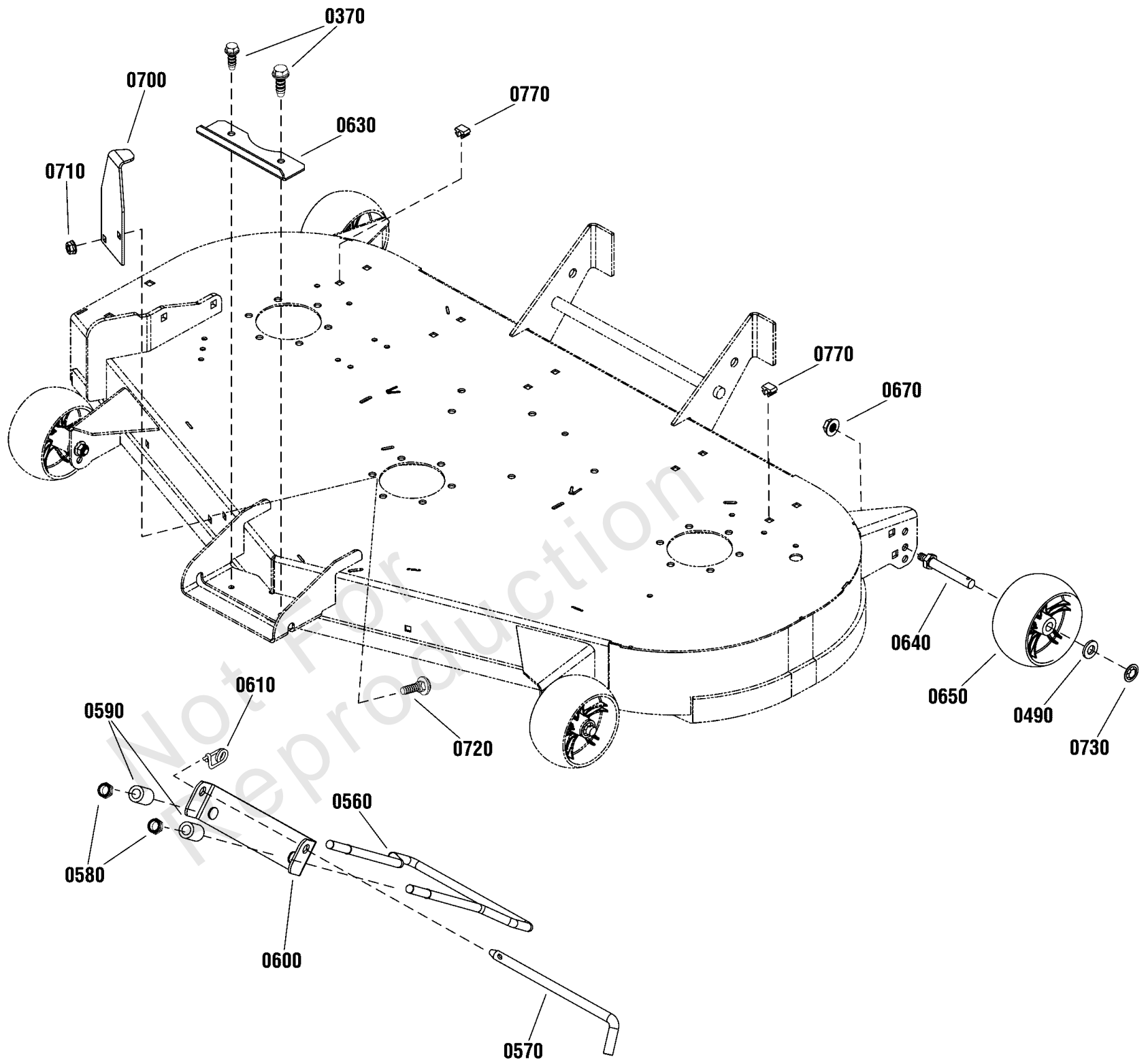

48" (122cm) Mower Deck - Height Adjustment Group

REF NO	PART NO	QTY	DESCRIPTION
0370	703228	2	SCREW, 5/16-18 X .75
0490	703853	4	WASHER, 0.516IDX1OD
0560	1730097SM	1	ROD, Bail, 1/2
0570	1731414SM	1	ROD, Latch, 1/2
0580	1960379SM	2	NUT, Hex Lock, 1/2-13
0590	1679166SM	2	SPACER, 1/2 x 7/8 x 1 3/16
0600	1730221BMYP	1	HANGER, Front
0610	703852	1	PIN, 5/16 X 0.375
0630	1757501BMYP	1	PLATE, Hitch Rod, Lock
0640	094025MA	4	BOLT, Gauge Wheel
0650	1736896YP	4	WHEEL, GAUGE
0670	703158	4	NUT, Hex Flange, 3/8-16
0700	1757805BMYP	1	BRACKET, Up Stop
0710	703409	2	NUT, 5/16-18, GR5
0720	703225	2	BOLT
0730	705437	4	PUSH NUT, Flat
0770	1705115SM	4	PLUG, Button

Not For Reproduction

48" (122cm) Mower Deck - Housing, Arbors & Blades Group

REF NO	PART NO	QTY	DESCRIPTION
0005	1687952	1	KIT, Mower Deck, Orange
0005	1687951	1	KIT, Mower Deck, Red
0010	7035813SM	1	SPRING, TORSION, SIDE
0020	1759055YP	3	BLADE, 48" (122cm)
0030	1656916SM	6	WASHER, SPRING 0.475I
0040	1732951SM	3	PULLEY-04.60 OD 1.000
0050	1758982BMYP	1	BRACKET, Deflector
0060	706362	2	SPACER, HUB
0070	84001645	1	ARBOR ASSEMBLY -(Replaced by Ref. Nos. 1000, this arbor assembly is an exact replacement)
0070-05	1704314SM	1	LUBE FITTING, .250 DR
0070-10	1755437YP	1	HOUSING, w/Lube Fitting
0070-20	1735399YP	2	BEARING, Ball, 20mm
0070-30	1760276YP	1	SHAFT-SPINDLE -(Replaced by Ref. Nos. 1000-30, this spindle shaft is an exact replacement)
0070-40	1735323YP	2	SHIELD, Arbor
0070-50	1735328YP	2	SPACER, Bearing -(Replaced by Ref. Nos. 1000-50, this spacer is an exact replacement)
0070-60	1960766YP	2	RING, SELF LOCKING
1000	84003173	3	ARBOR ASSEMBLY
1000-05	1704314SM	1	LUBE FITTING, .250 DR
1000-10	84003653	1	HOUSING ASSEMBLY
1000-20	1735399YP	2	BEARING, Ball, 20mm
1000-30	84003170	1	SHAFT, SPINDLE
1000-40	84003166	1	COVER, ARBOR
1000-50	84003167	1	SPACER, BEARING
1000-60	1960766YP	1	RING, SELF LOCKING
0090	704146	18	SCREW, HEX, 5/16-18X1
0100	703179	1	PUSHNUT, CAP TYPE
0120	7104640YP	1	ROD, Deflector
0130	7104733YP	1	CHUTE, SIDE DISCHARGE
0140	703793	2	LOCKNUT
0150	703815	2	BOLT, RD SQ 3/8-16X1
0160	1921212SM	2	CAPSCREW, Hex Head, 7/16-14 X 1 1/2
0170	705439	1	CAPSCREW, Hex Head, 7/16-14 X 3 1/4
0200	703228	6	SCREW, 5/16-18 X .75
0210	2820676SM	3	CAPSCREW-HEX HD 7/16-
0230	1735716YP	1	ADAPTER, Washout Port
0240	1756246YP	1	CONNECTOR, Washout Port
0250	703235	1	SCREW, 5/16-18 X 3/4
0270	706364	1	SPACER, HUB
0280	1759102BMYP	1	COVER, Pulley, LH
0310	1759101BMYP	1	COVER, Pulley, RH
0320	706368	1	BAFFLE, Pinchoff
0330	703185	2	BOLT, Round Head, Short Square Neck
0340	703115	2	NUT
0350	1758593BMYP	1	PROP, DEFLECTOR

Controls Group

Note: Unless noted otherwise, use the standard torque specifications

Mfg. No: 2691664-01

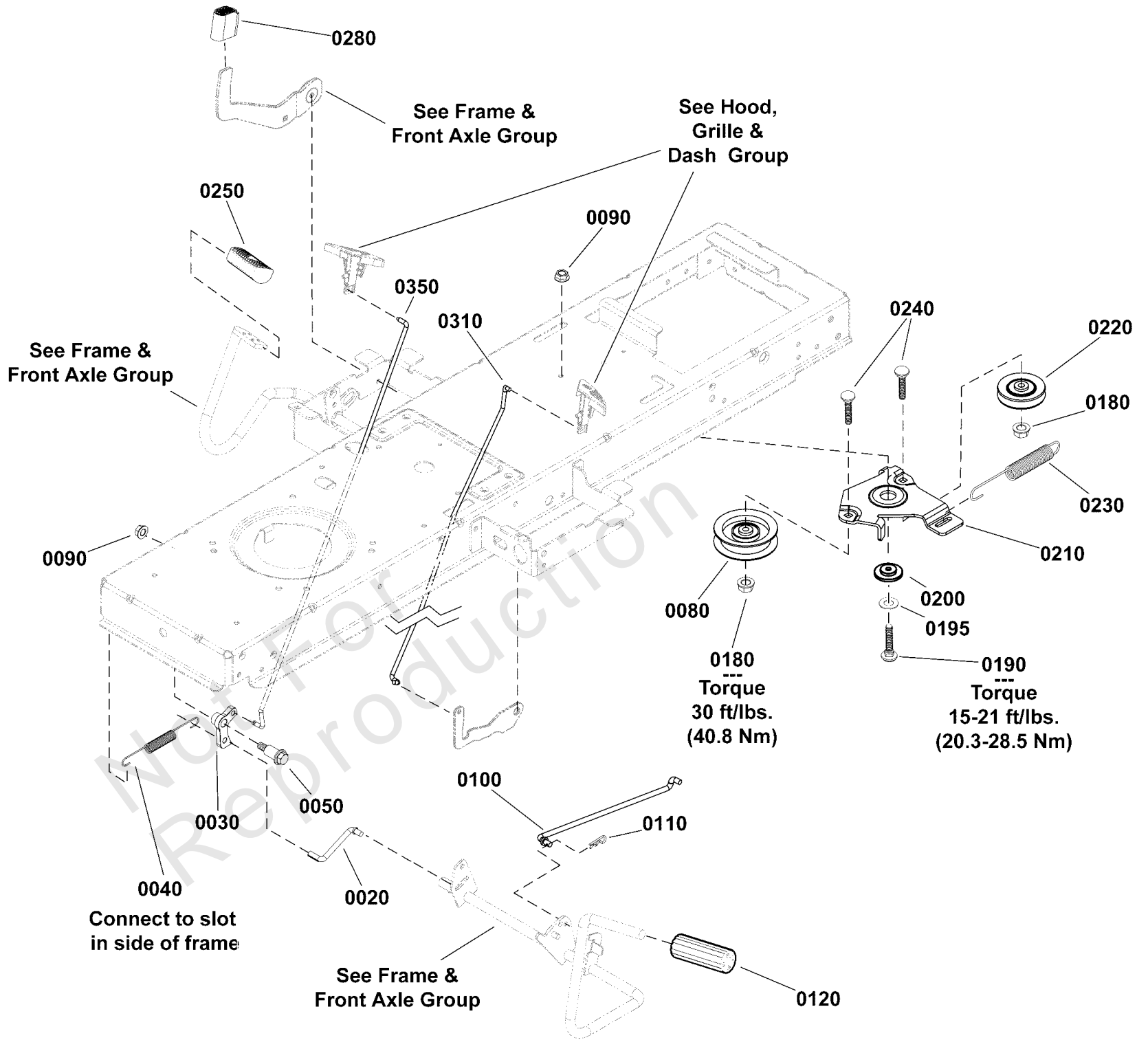

Controls Group

REF NO	PART NO	QTY	DESCRIPTION
0020	1727899SM	1	ROD, Cruise Latch, 5/16 Dia. x 2-13/16 Long
0030	1727897SM	1	LATCH, Cruise
0040	2159181SM	1	SPRING, Extension, 9/16 OD x 7-3/4
0050	1728976SM	1	BOLT, Shoulder, 5/16-18 x 1-5/8
0080	1728000SM	1	PULLEY, Idler, 3-1/8 OD, 3/8 ID
0090	703115	2	NUT
0100	1727254SM	1	ROD, Brake Return, 5/16 Dia. x 12-5/8 Long
0110	1722460SM	1	PIN, Quick, 1-3/16 Long
0120	1727261SM	1	PEDAL-BRAKE BLACK RUB
0180	1960687SM	2	NUT, Hex Flange, ESNA, 3/8-16
0190	703570	1	CAPSCREW, Hex Head, 5/16-18 x 1 1/4
0195	1919326SM	1	WASHER, 5/16
0200	1727935SM	1	SPACER-PIVOT 0.330ID
0210	1727894ASM	1	BRACKET, Idler
0220	1728001SM	1	PULLEY, 3 OD, 3/8 ID
0230	1729620SM	1	SPRING, Extension, 1 OD x 7-1/2
0240	1931352SM	2	BOLT, Carriage, Short Neck, 3/8-16 x 1-1/2
0250	1721675SM	1	PAD, Foot Pedal, Forward
0280	1727259SM	1	PAD, Foot Pedal, Reverse
0310	1739876YP	1	ROD, Parking Brake, 1/4 Dia. x 16-3/8 Long
0350	1739877YP	1	ROD, Cruise Latch, 1/4 Dia. x 17

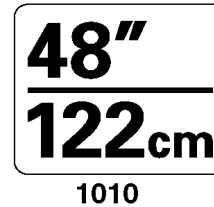
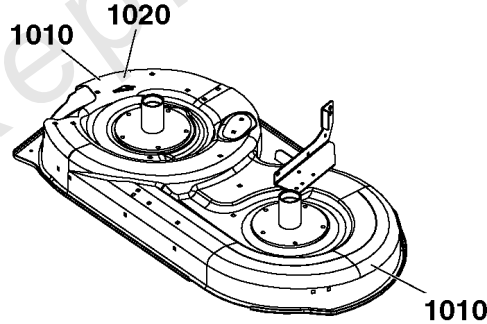
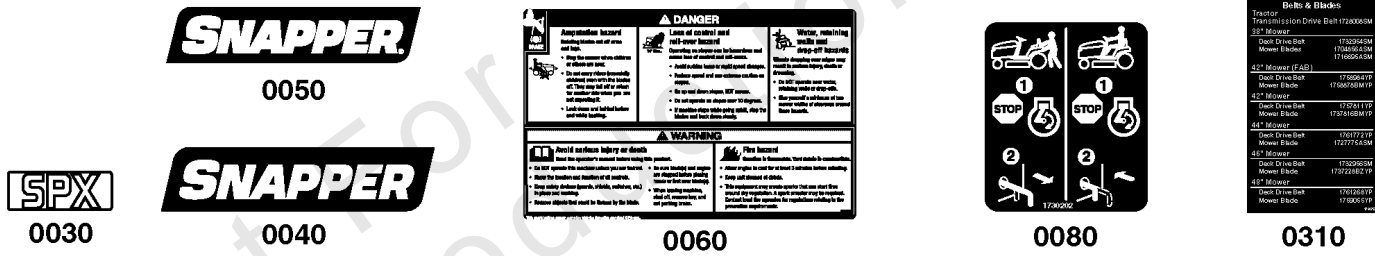
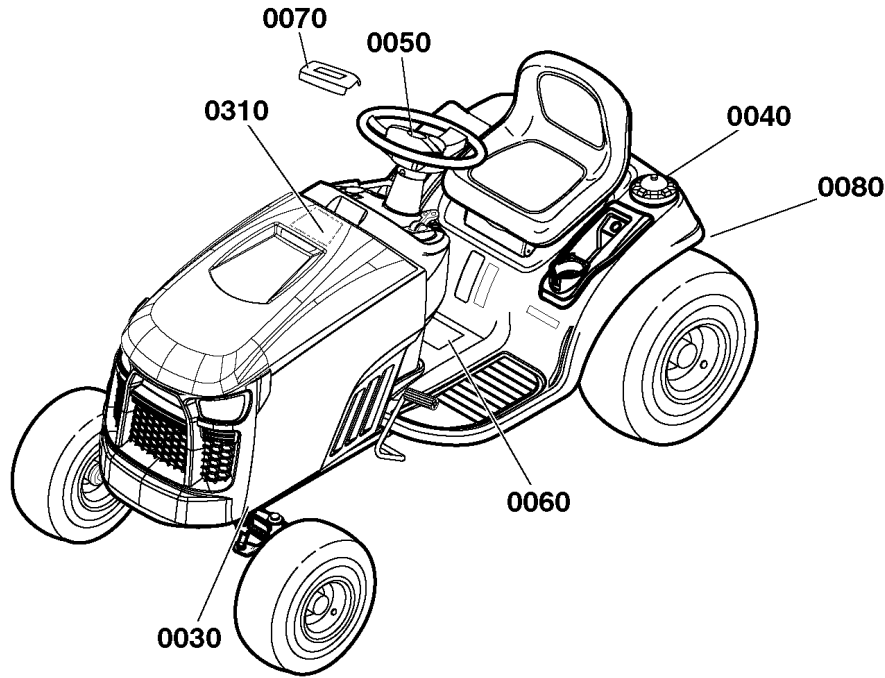

Decals Group

REF NO	PART NO	QTY	DESCRIPTION
0030	7104875YP	2	DECAL, Front Cover, SPX Series
0040	1750913YP	1	DECAL, SNAPPER LOGO
0050	84002249	1	DECAL, Snapper Logo, 3.1" X .8"
0060	1755395YP	1	DECAL, Tunnel
0070	84002250	1	CAP, Steering Wheel
0080	1730202SM	1	DECAL, Transmission Tow / Release Lever
0310	1761757YP	1	DECAL, Service
1010	1755719YP	1	DECAL, 48"/122cm
1020	7101665YP	2	DECAL, DANGER

Not For Reproduction

Electrical Group

Note: Unless noted otherwise, use the standard torque specifications

Mfg. No: 2691664-01

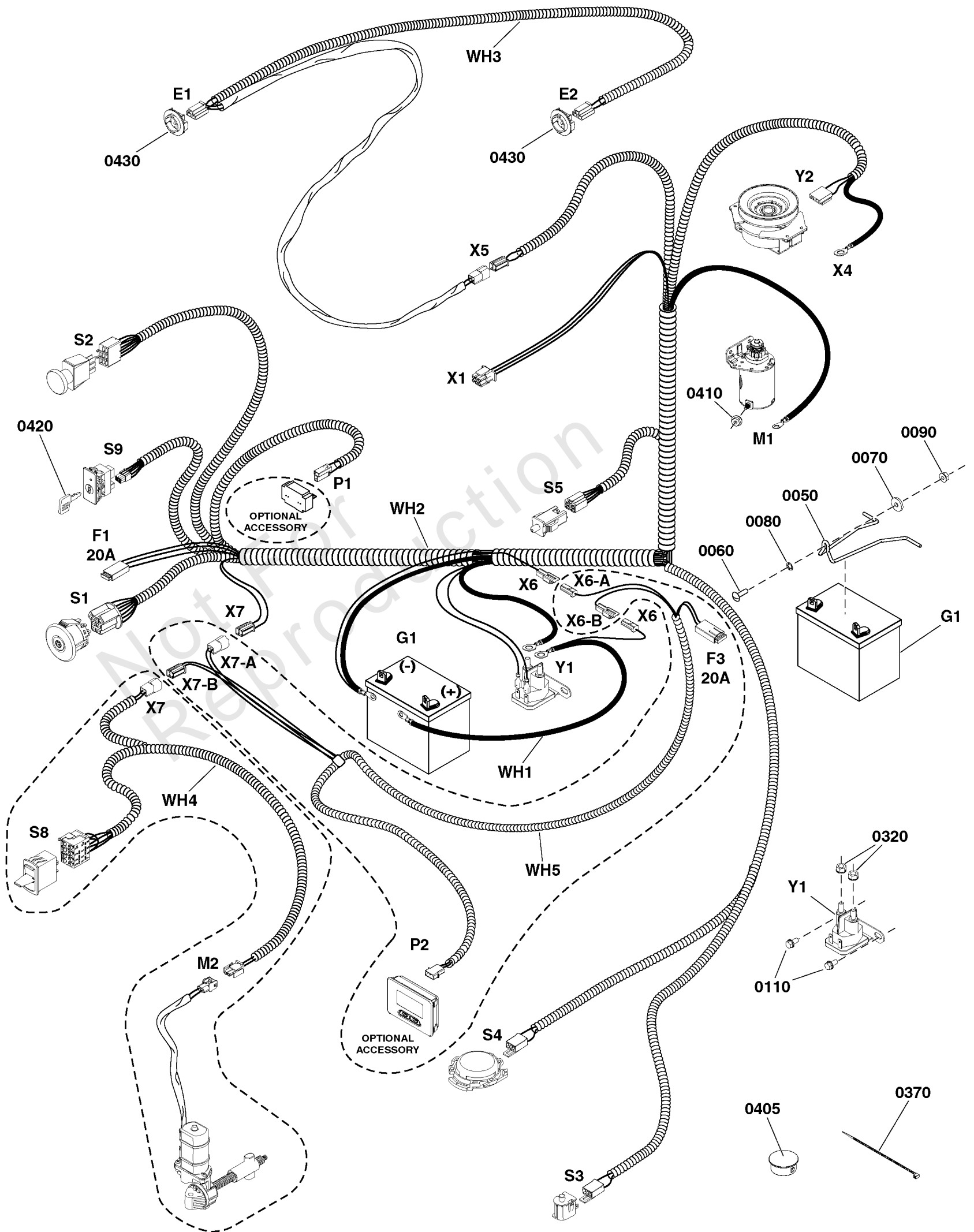

Electrical Group

REF NO	PART NO	QTY	DESCRIPTION
E1	-----	1	HEADLIGHT, Left
E2	-----	1	HEADLIGHT, Right
F1	1731957SM	1	FUSE, Wiring Harness
F3	1731957SM	1	FUSE, Wiring Harness
G1	-----	1	BATTERY, 12 Volt, 230 CCA
M1	592599	1	MOTOR, Starter
M2	1761788YP	1	MOTOR, Electric -(Optional Accessory)
P1	1731185SM	1	METER-HOUR DIGITAL NO -(Optional Accessory)
P2	1758654YP	1	DISPLAY, Mini Meter -(Optional Accessory)
S1	1761507YP	1	SWITCH, Ignition
S2	1722887YP	1	SWITCH, PTO Push/Pull, Yel Knob w/Symbols, 8 Terminal
S3	1720411SM	1	SWITCH, NO, Black, Push Button W/Boot -(Reverse Switch)
S4	1714771SM	1	SWITCH, Seat, Gray Switch, Gray Retainer
S5	7022886YP	1	SWITCH, DP NO/NC SNAP -(Brake Pedal Switch)
S8	1761475YP	1	SWITCH, Height of Cut -(Optional Accessory)
S9	1761897YP	1	SWITCH, Reverse Mow Option
WH1	1759779YP	1	HARNESS, Battery, Solenoid
WH2	1761300YP	1	HARNESS, Main
WH3	1761298YP	1	HARNESS, Headlight
WH4	1761347YP	1	HARNESS, Height of Cut -(Optional Accessory)
WH5	84003001	1	HARNESS, Mini Meter with Height of Cut Harness -(Optional Accessory)
X1	-----	1	CONNECTOR, Engine
X4	-----	1	CHASSIS GROUND POINT
X5	-----	1	CONNECTOR, Main Harness to Headlight Harness
X6	-----	1	CONNECTOR, Battery Solenoid Harness to Main Harness
X6-A	-----	1	CONNECTOR, Mini Meter with Height of Cut Harness to Main Harness
X6-B	-----	1	CONNECTOR, Mini Meter with Height of Cut Harness to Battery Solenoid Harness
X7	-----	1	CONNECTOR, Main Harness to Height of Cut Harness
X7-A	-----	1	CONNECTOR, Mini Meter with Height of Cut Harness to Main Harness
X7-B	-----	1	CONNECTOR, Mini Meter with Height of Cut Harness to Height of Cut Harness
Y1	1755381YP	1	SOLENOID, L-BRACKET -(Starter Solenoid)
Y2	1760986YP	1	OGURA CLUTCH -(PTO Clutch)
0050	1730007SM	1	HOLD DOWN, Battery, 1/4 Dia.
0060	1931318SM	1	BOLT, Carriage, Short Neck, 1/4-20 x 7/8 G5
0070	703229	1	WASHER, 1/4
0080	703826	1	BOLT, PUSHNUT 1/4
0090	703463	1	NUT, GR5, 1/4-20
0110	704130	2	SCREW, HEX, 1/4-20X.5
0320	2860750SM	2	NUT-HEX KEPS 5/16-24
0370	703586	3	TIE, SELF LOCKING
0405	1732007SM	1	PLUG, Hole, 7/8 Dia.
0410	703061	1	NUT, HEX KEPS, 1/4-20
0420	1726557SM	2	KEY, No Mow Module (Yellow)

Electrical Group

Note: Unless noted otherwise, use the standard torque specifications

Mfg. No: 2691664-01

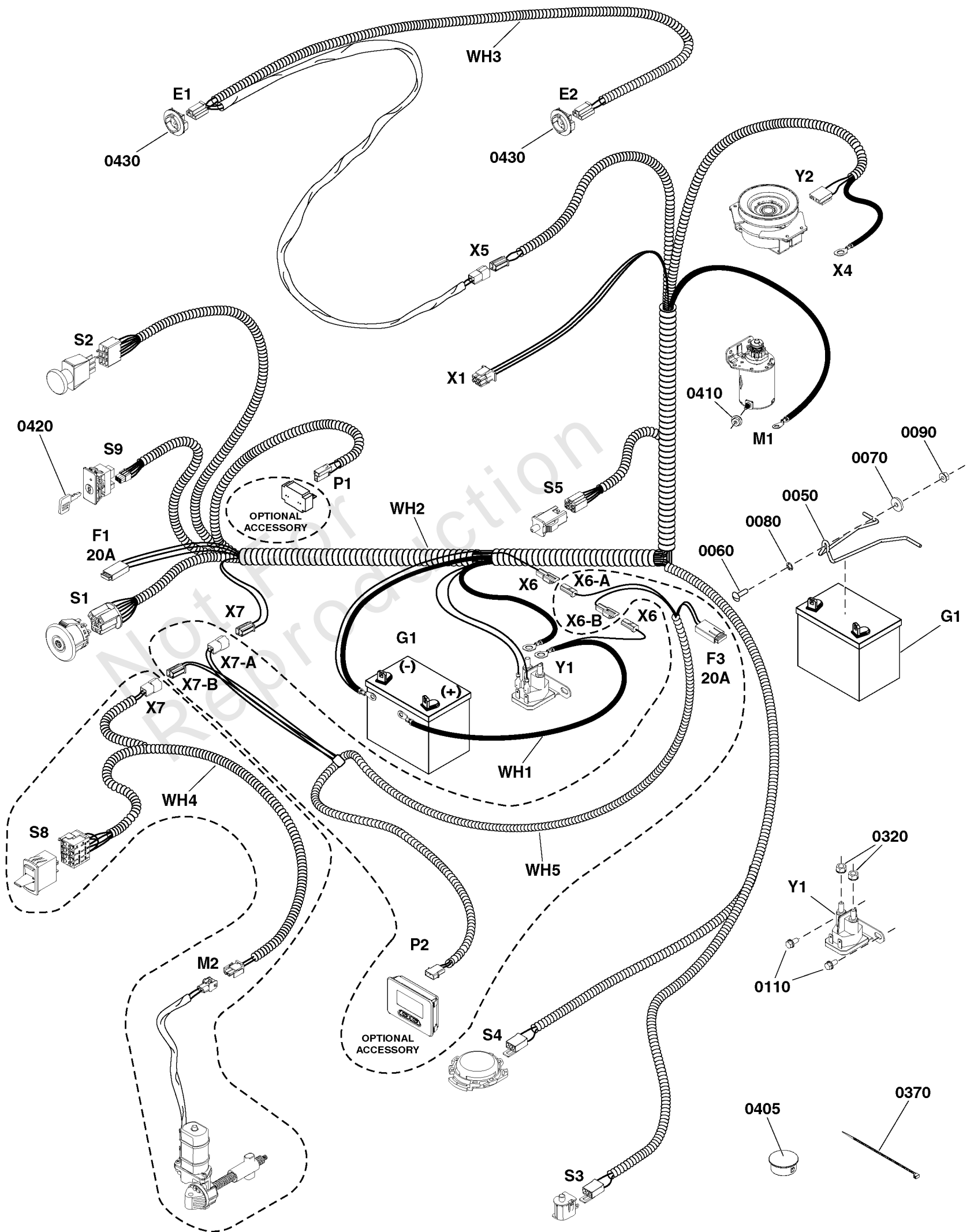

Electrical Group

REF NO	PART NO	QTY	DESCRIPTION
0430	1760239YP	2	LED HEADLIGHT AND SOCKET ASSEMBLY

Not For Reproduction

Electrical Schematic -

Note: Unless noted otherwise, use the standard torque specifications

Mfg. No: 2691664-01

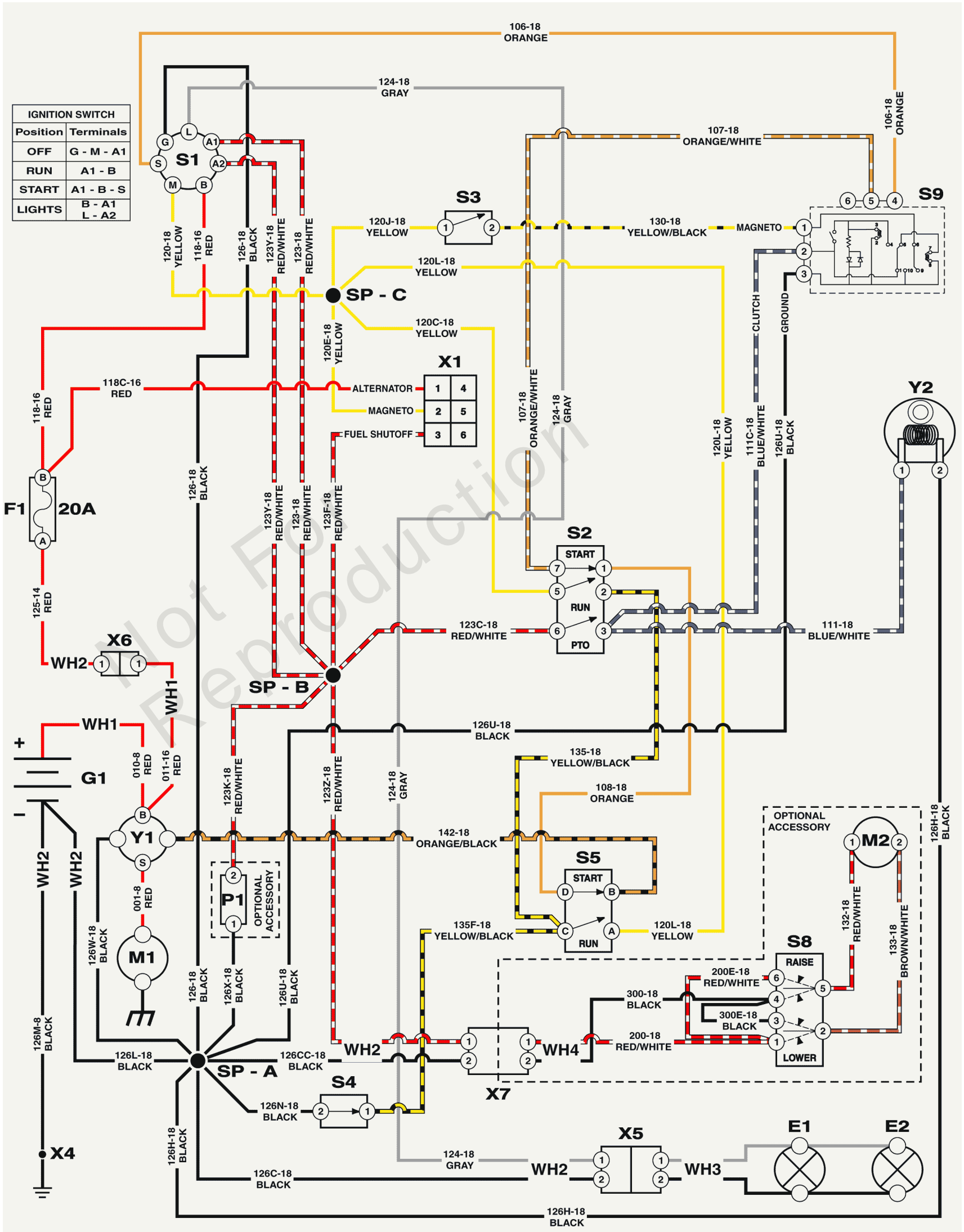

Electrical Schematic -

REF NO	PART NO	QTY	DESCRIPTION
	-----		NOTE: All electrical components represented within this electrical schematic are at rest state (no power applied).
E1	-----	1	HEADLIGHT, Left
E2	-----	1	HEADLIGHT, Right
F1	1731957SM	1	FUSE, Wiring Harness
G1	-----	1	BATTERY, 12 Volt, 230 CCA
M1	592599	1	MOTOR, Starter
M2	1761788YP	1	MOTOR, Electric -(Optional Accessory)
P1	1731185SM	1	METER-HOUR DIGITAL NO -(Optional Accessory)
S1	1761507YP	1	SWITCH, Ignition
S2	1722887YP	1	SWITCH, PTO Push/Pull, Yel Knob w/Symbols, 8 Terminal
S3	1720411SM	1	SWITCH, NO, Black, Push Button W/Boot -(Reverse Switch)
S4	1714771SM	1	SWITCH, Seat, Gray Switch, Gray Retainer
S5	7022886YP	1	SWITCH, DP NO/NC SNAP -(Brake Pedal Switch)
S8	1761475YP	1	SWITCH, Height of Cut -(Optional Accessory)
S9	1761897YP	1	SWITCH, Reverse Mow Option
SP-A	-----	1	SPLICE - A -(Splices are internal to the wire harness.)
SP-B	-----	1	SPLICE - B -(Splices are internal to the wire harness.)
SP-C	-----	1	SPLICE - C -(Splices are internal to the wire harness.)
WH1	1759779YP	1	HARNESS, Battery, Solenoid
WH2	1761300YP	1	HARNESS, Main
WH3	1761298YP	1	HARNESS, Headlight
WH4	1761347YP	1	HARNESS, Height of Cut -(Optional Accessory)
X1	-----	1	CONNECTOR, Engine
X4	-----	1	CHASSIS GROUND POINT
X5	-----	1	CONNECTOR, Main Harness to Headlight Harness
X6	-----	1	CONNECTOR, Battery Solenoid Harness to Main Harness
X7	-----	1	CONNECTOR, Main Harness to Height of Cut Harness
Y1	1755381YP	1	SOLENOID, L-BRACKET -(Starter Solenoid)
Y2	1760986YP	1	OGURA CLUTCH -(PTO Clutch)

Electrical Schematic - Charging Circuit

Note: Unless noted otherwise, use the standard torque specifications

Mfg. No: 2691664-01

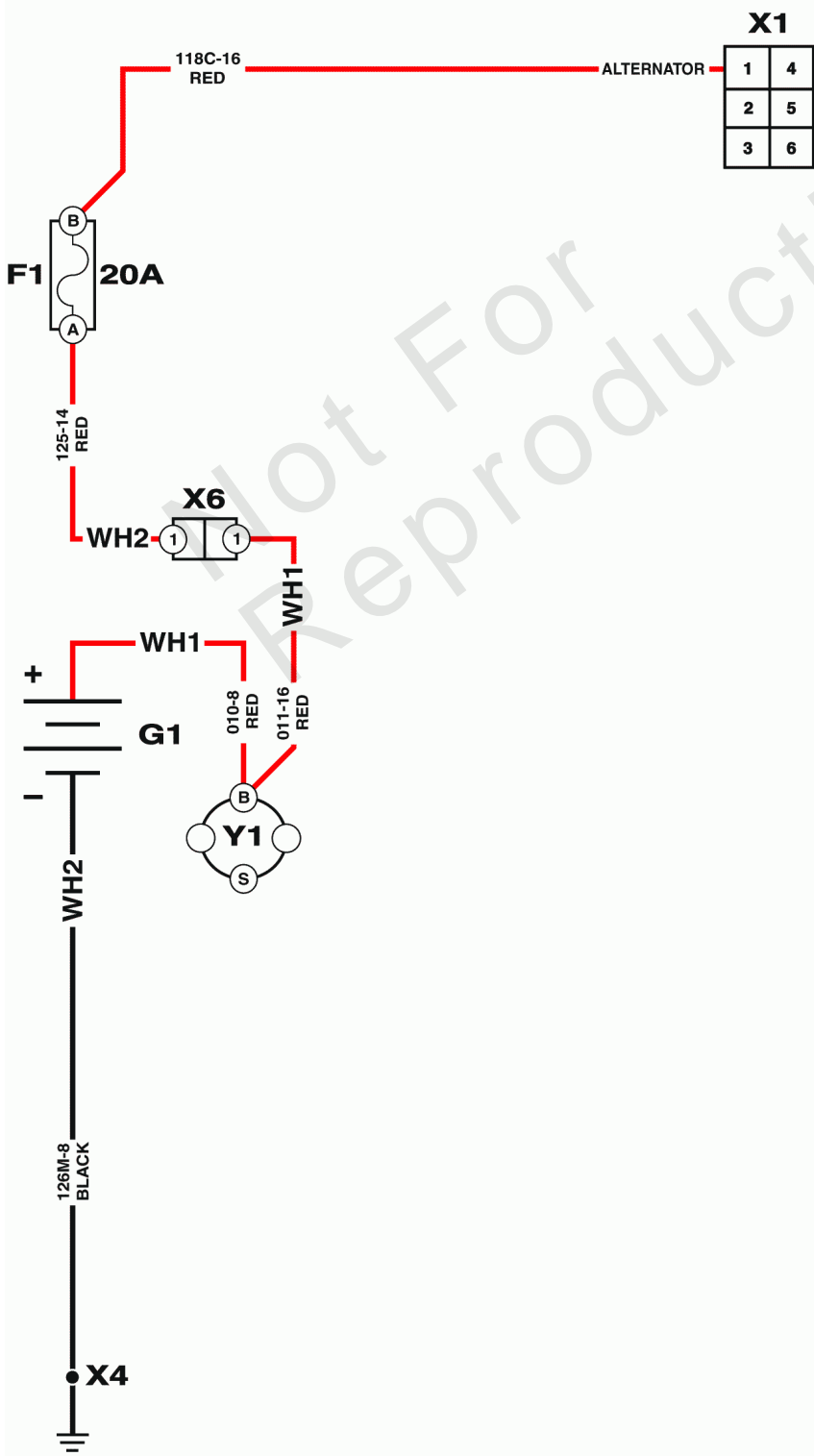

Electrical Schematic - Charging Circuit

REF NO	PART NO	QTY	DESCRIPTION
	-----		NOTE: All electrical components represented within this electrical schematic are at rest state (no power applied).
F1	1731957SM	1	FUSE, Wiring Harness
G1	-----	1	BATTERY, 12 Volt, 230 CCA
WH1	1759779YP	1	HARNESS, Battery, Solenoid
WH2	1761300YP	1	HARNESS, Main
X1	-----	1	CONNECTOR, Engine
X4	-----	1	CHASSIS GROUND POINT
X6	-----	1	CONNECTOR, Battery Solenoid Harness to Main Harness
Y1	1755381YP	1	SOLENOID, L-BRACKET -(Starter Solenoid)

Not For Reproduction

Electrical Schematic - Cranking Circuit

REF NO	PART NO	QTY	DESCRIPTION
	-----		NOTE: All electrical components represented within this electrical schematic are at rest state (no power applied).
F1	1731957SM	1	FUSE, Wiring Harness
G1	-----	1	BATTERY, 12 Volt, 230 CCA
M1	592599	1	MOTOR, Starter
S1	1761507YP	1	SWITCH, Ignition
S2	1722887YP	1	SWITCH, PTO Push/Pull, Yel Knob w/Symbols, 8 Terminal
S5	7022886YP	1	SWITCH, DP NO/NC SNAP -(Brake Pedal Switch)
S9	1761897YP	1	SWITCH, Reverse Mow Option
SP-A	-----	1	SPLICE - A -(Splices are internal to the wire harness.)
SP-B	-----	1	SPLICE - B -(Splices are internal to the wire harness.)
WH1	1759779YP	1	HARNESS, Battery, Solenoid
WH2	1761300YP	1	HARNESS, Main
X1	-----	1	CONNECTOR, Engine
X4	-----	1	CHASSIS GROUND POINT
X6	-----	1	CONNECTOR, Battery Solenoid Harness to Main Harness
Y1	1755381YP	1	SOLENOID, L-BRACKET -(Starter Solenoid)

Electrical Schematic - Headlight Circuit

Note: Unless noted otherwise, use the standard torque specifications

Mfg. No: 2691664-01

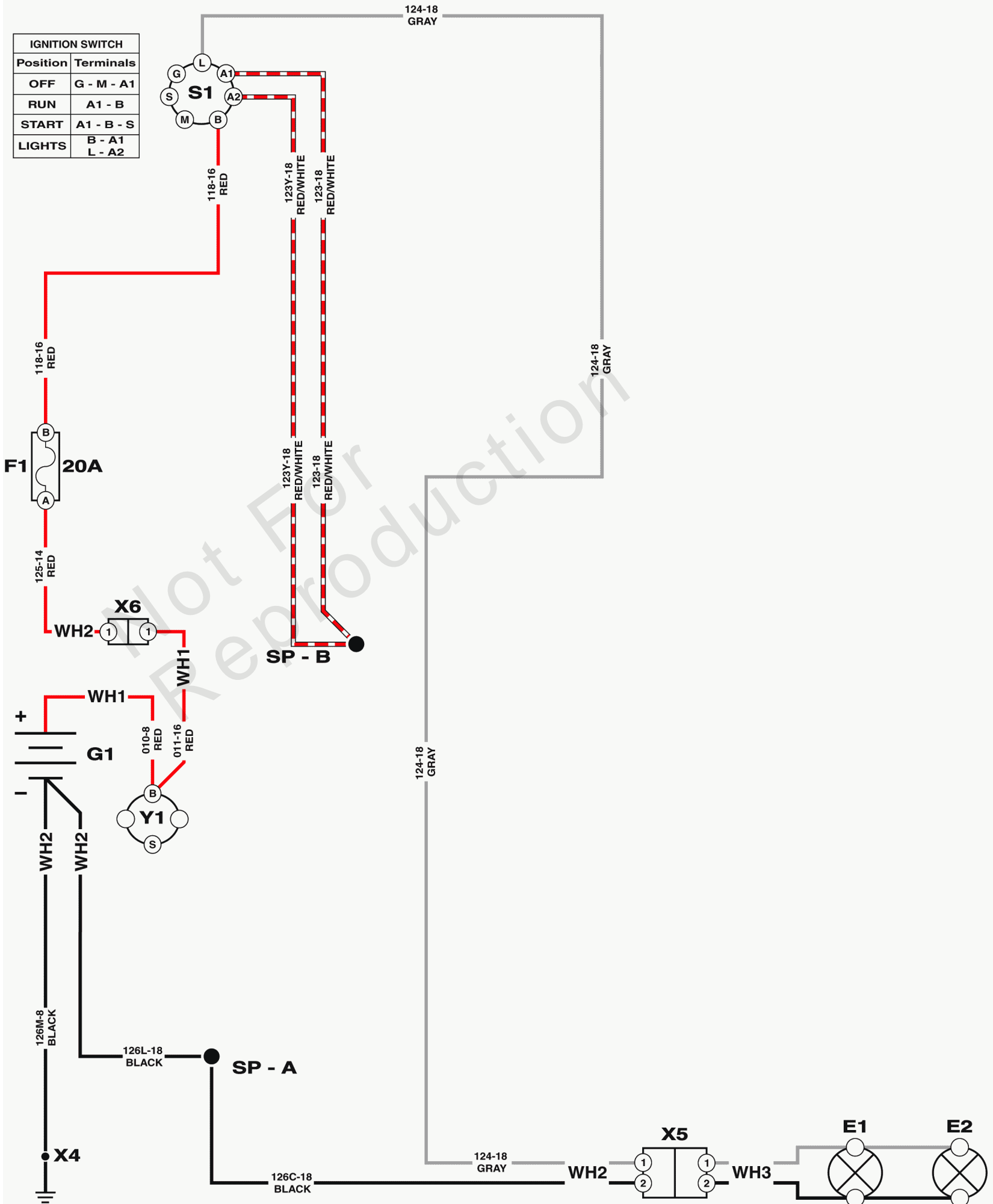

Electrical Schematic - Headlight Circuit

REF NO	PART NO	QTY	DESCRIPTION
	-----		NOTE: All electrical components represented within this electrical schematic are at rest state (no power applied).
E1	-----	1	HEADLIGHT, Left
E2	-----	1	HEADLIGHT, Right
F1	1731957SM	1	FUSE, Wiring Harness
G1	-----	1	BATTERY, 12 Volt, 230 CCA
S1	1761507YP	1	SWITCH, Ignition
SP-A	-----	1	SPLICE - A -(Splices are internal to the wire harness.)
SP-B	-----	1	SPLICE - B -(Splices are internal to the wire harness.)
WH1	1759779YP	1	HARNESS, Battery, Solenoid
WH2	1761300YP	1	HARNESS, Main
WH3	1761298YP	1	HARNESS, Headlight
X4	-----	1	CHASSIS GROUND POINT
X5	-----	1	CONNECTOR, Main Harness to Headlight Harness
X6	-----	1	CONNECTOR, Battery Solenoid Harness to Main Harness
Y1	1755381YP	1	SOLENOID, L-BRACKET -(Starter Solenoid)

Electrical Schematic - Height of Cut

Note: Unless noted otherwise, use the standard torque specifications

Mfg. No: 2691664-01

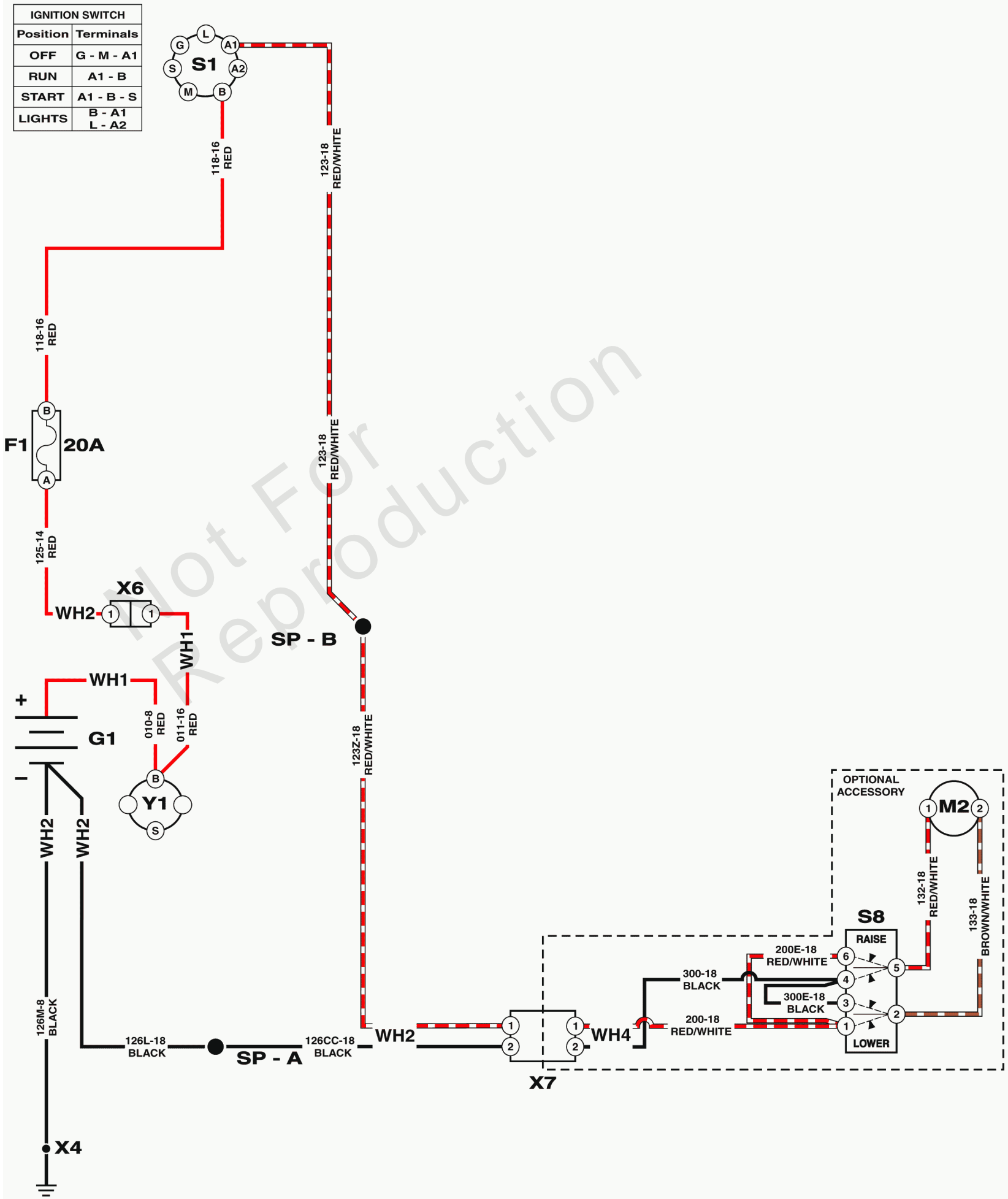

Electrical Schematic - Height of Cut

REF NO	PART NO	QTY	DESCRIPTION
	-----		NOTE: All electrical components represented within this electrical schematic are at rest state (no power applied).
F1	1731957SM	1	FUSE, Wiring Harness
G1	-----	1	BATTERY, 12 Volt, 230 CCA
M2	1761788YP	1	MOTOR, Electric -(Optional Accessory)
S1	1761507YP	1	SWITCH, Ignition
S8	1761475YP	1	SWITCH, Height of Cut -(Optional Accessory)
SP-A	-----	1	SPLICE - A -(Splices are internal to the wire harness.)
SP-B	-----	1	SPLICE - B -(Splices are internal to the wire harness.)
WH1	1759779YP	1	HARNESS, Battery, Solenoid
WH2	1761300YP	1	HARNESS, Main
WH4	1761347YP	1	HARNESS, Height of Cut -(Optional Accessory)
X4	-----	1	CHASSIS GROUND POINT
X6	-----	1	CONNECTOR, Battery Solenoid Harness to Main Harness
X7	-----	1	CONNECTOR, Main Harness to Height of Cut Harness
Y1	1755381YP	1	SOLENOID, L-BRACKET -(Starter Solenoid)

Electrical Schematic - Hour Meter

Note: Unless noted otherwise, use the standard torque specifications

Mfg. No: 2691664-01

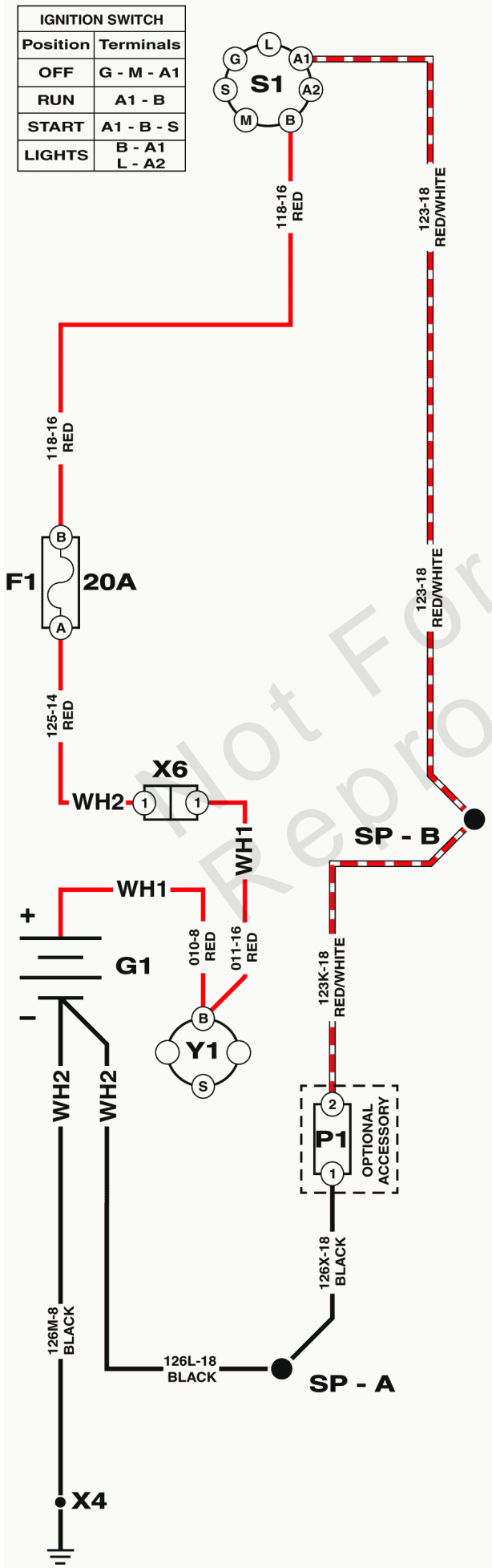

Electrical Schematic - Hour Meter

REF NO	PART NO	QTY	DESCRIPTION
	-----		NOTE: All electrical components represented within this electrical schematic are at rest state (no power applied).
F1	1731957SM	1	FUSE, Wiring Harness
G1	-----	1	BATTERY, 12 Volt, 230 CCA
P1	1731185SM	1	METER-HOUR DIGITAL NO -(Optional Accessory)
S1	1761507YP	1	SWITCH, Ignition
SP-A	-----	1	SPLICE - A -(Splices are internal to the wire harness.)
SP-B	-----	1	SPLICE - B -(Splices are internal to the wire harness.)
WH1	1759779YP	1	HARNESS, Battery, Solenoid
WH2	1761300YP	1	HARNESS, Main
X4	-----	1	CHASSIS GROUND POINT
X6	-----	1	CONNECTOR, Battery Solenoid Harness to Main Harness
Y1	1755381YP	1	SOLENOID, L-BRACKET -(Starter Solenoid)

Electrical Schematic - Ignition Shutdown

Note: Unless noted otherwise, use the standard torque specifications

Mfg. No: 2691664-01

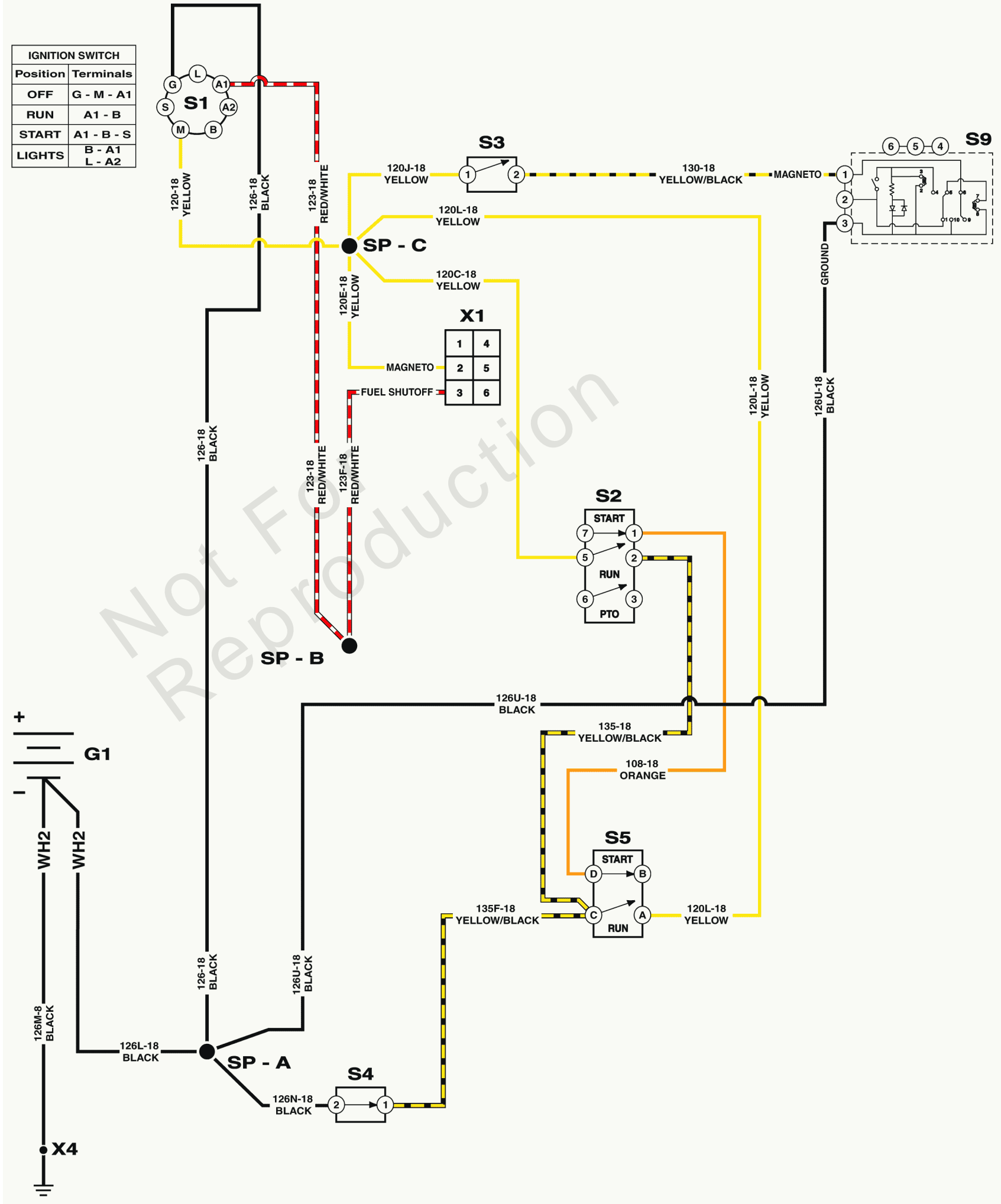

IGNITION SWITCH	
Position	Terminals
OFF	G - M - A1
RUN	A1 - B
START	A1 - B - S
LIGHTS	B - A1 L - A2

X1	
1	4
2	5
3	6

Electrical Schematic - Ignition Shutdown

REF NO	PART NO	QTY	DESCRIPTION
	-----		NOTE: All electrical components represented within this electrical schematic are at rest state (no power applied).
G1	-----	1	BATTERY, 12 Volt, 230 CCA
S1	1761507YP	1	SWITCH, Ignition
S2	1722887YP	1	SWITCH, PTO Push/Pull, Yel Knob w/Symbols, 8 Terminal
S3	1720411SM	1	SWITCH, NO, Black, Push Button W/Boot -(Reverse Switch)
S4	1714771SM	1	SWITCH, Seat, Gray Switch, Gray Retainer
S5	7022886YP	1	SWITCH, DP NO/NC SNAP -(Brake Pedal Switch)
S9	1761897YP	1	SWITCH, Reverse Mow Option
SP-A	-----	1	SPLICE - A -(Splices are internal to the wire harness.)
SP-B	-----	1	SPLICE - B -(Splices are internal to the wire harness.)
SP-C	-----	1	SPLICE - C -(Splices are internal to the wire harness.)
WH2	1761300YP	1	HARNESS, Main
X1	-----	1	CONNECTOR, Engine
X4	-----	1	CHASSIS GROUND POINT

Electrical Schematic - PTO Clutch Circuit

Note: Unless noted otherwise, use the standard torque specifications

Mfg. No: 2691664-01

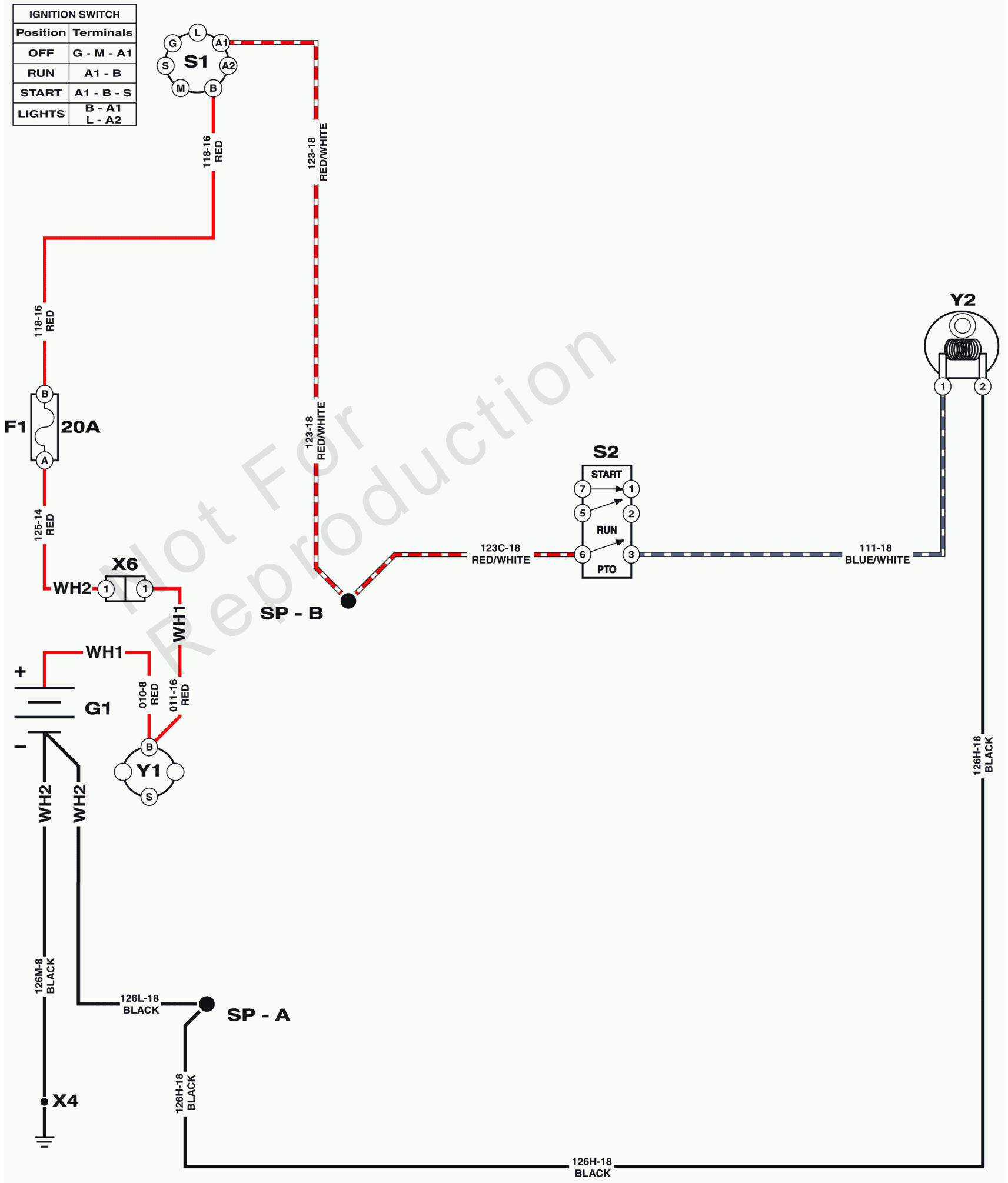

Electrical Schematic - PTO Clutch Circuit

REF NO	PART NO	QTY	DESCRIPTION
	-----		NOTE: All electrical components represented within this electrical schematic are at rest state (no power applied).
F1	1731957SM	1	FUSE, Wiring Harness
G1	-----	1	BATTERY, 12 Volt, 230 CCA
S1	1761507YP	1	SWITCH, Ignition
S2	1722887YP	1	SWITCH, PTO Push/Pull, Yel Knob w/Symbols, 8 Terminal
SP-A	-----	1	SPLICE - A -(Splices are internal to the wire harness.)
SP-B	-----	1	SPLICE - B -(Splices are internal to the wire harness.)
WH1	1759779YP	1	HARNESS, Battery, Solenoid
WH2	1761300YP	1	HARNESS, Main
X4	-----	1	CHASSIS GROUND POINT
X6	-----	1	CONNECTOR, Battery Solenoid Harness to Main Harness
Y1	1755381YP	1	SOLENOID, L-BRACKET -(Starter Solenoid)
Y2	1760986YP	1	OGURA CLUTCH -(PTO Clutch)

Engine Group

Note: Unless noted otherwise, use the standard torque specifications

Mfg. No: 2691664-01

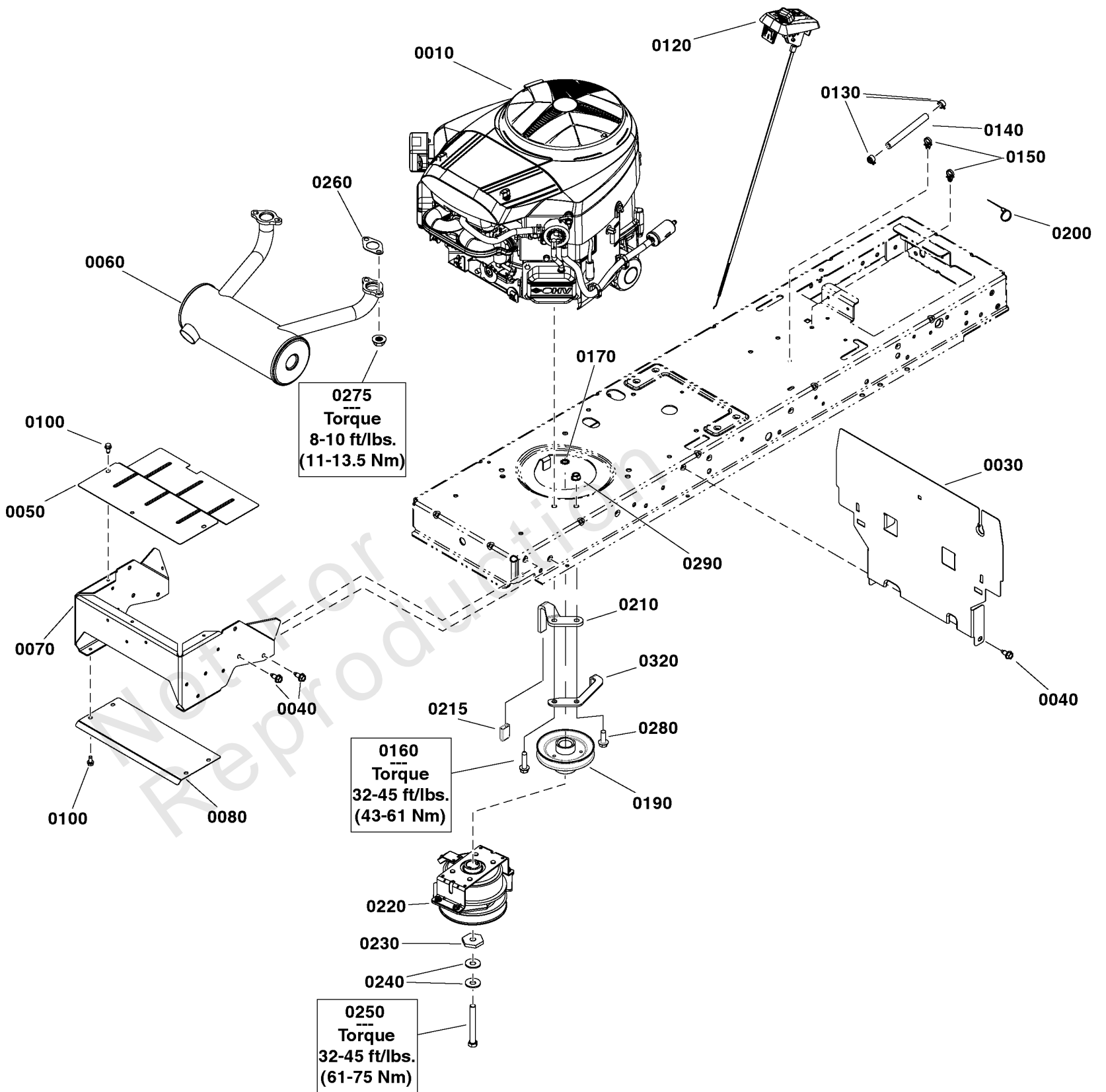

Engine Group

REF NO	PART NO	QTY	DESCRIPTION
0010	44S977-0048-G1	1	* ENGINE, 25 Gross HP Briggs & Stratton Pro Series, VS Twin -(Engine Model: 44S977-0048-G1)
0030	1738380AYP	1	HEAT SHIELD, Engine
0040	703228	6	SCREW, 5/16-18 X .75
0050	1761064CJYP	1	HEAT SHIELD
0060	1761127YP	1	MUFFLER, Twin
0070	1761211CJYP	1	Support, Muffler
0080	1761063CJYP	1	HEAT SHIELD, Bottom
0100	704130	7	SCREW, HEX, 1/4-20X.5
0120	1759240YP	1	THROTTLE
0130	791850	2	CLAMP, Hose
0140	845503	1	LINE-FUEL
0150	1730268SM	2	CLIP, Hose, 1/2 Dia., Push In
0160	704010	4	SCREW, HEX, 3/8-16
0170	703864	1	WASHER, EXT, 3/8
0190	1732576SM	1	PULLEY & HUB ASSEMBLY, Engine
0200	703586	1	TIE, SELF LOCKING
0210	1760323CJYP	1	CLUTCH, Anchor
0215	84002544	1	Sleeve, Clutch Anchor
0220	1760986YP	1	OGURA CLUTCH -(Position clutch as illustrated)
0230	1708264SM	1	WASHER, HEX, 0.453ID
0240	1960769YP	2	WASHER, Belleville
0250	771023	1	CAPSCREW, Hex Head, Loctite, 7/16-20 x 3 1/2
0260	690970	2	GASKET, Exhaust
0275	690941	4	NUT
0280	704038	1	SCREW
0290	703333	1	NUT, 3/8-16
0320	84004562	1	GUIDE, Belt

Footnotes:

Note* See your local Briggs & Stratton distributor for parts & service.

Frame & Front Axle Group

REF NO	PART NO	QTY	DESCRIPTION
0050	1730186SM	2	BUSHING, Axle Pivot
0080	1727902SM	1	PLATE, Axle Support
0090	2860646SM	1	NUT, Hex Flange, 5/8-11
0100	703409	26	NUT, 5/16-18, GR5
0180	-----	1	FRAME
0190	1759842BMYP	1	SUPPORT, Front Footrest, RH
0210	1758690YP	1	SUPPORT, Rear Frame
0220	703949	9	SCREW, 5/16-18.625
0230	703354	23	SCREW, 5/16-18
0240	1759841BMYP	1	SUPPORT, Front Footrest, LH
0280	1960035SM	1	WASHER-0.625(0.64IDX1
0290	2860744SM	1	CAPSCREW, Hex Head, 5/8-11 x 3 1/4
0300	1738051YP	1	LINK, Drag (with Bearing), 5/16
0320	1736404AYP	1	PEDAL ASSY, BRAKE
0330	1735595YP	1	LATCH, Brake Lock
0335	7014296YP	1	WASHER, Shim
0340	703851	1	BOLT, 5/16-18X1.15
0350	1727935SM	1	SPACER-PIVOT 0.330ID
0360	1736714AYP	1	FORWARD PEDAL ASSEMBLY
0370	1727246SM	1	PEDAL, Reverse
0380	703446	2	BOLT, 5/16-18X1.25 G5
0390	1728024SM	1	SPACER, Foot Pedal
0410	885591YP	1	BRACKET, PEDAL PIVOT
0420	1727911ASM	2	PLATE, Bearing
0430	1727282ASM	1	SUPPORT, Battery 12 GA
0470	1737957YP	1	LIFT SHAFT ASSEMBLY
0490	1761009YP	1	BRACKET, Sector Support
0500	1751110YP	1	GEAR, Steering
0510	1761011CJYP	1	PLATE, Sector Gear
0530	703185	2	BOLT, Round Head, Short Square Neck
0540	1727903ASM	2	SUPPORT, Transmission
0710	703570	4	CAPSCREW, Hex Head, 5/16-18 x 1 1/4
0720	1919326SM	4	WASHER, 5/16
0730	704067	6	NUT, HEX FLNG,5/16-18 -(Torque to 12-17 ft/lbs)
0740	-----	1	Refer to: Front Axle Group
1060	1761010YP	1	SUPPORT, Steering

Front Axle Group

Note: Unless noted otherwise, use the standard torque specifications

Mfg. No: 2691664-01

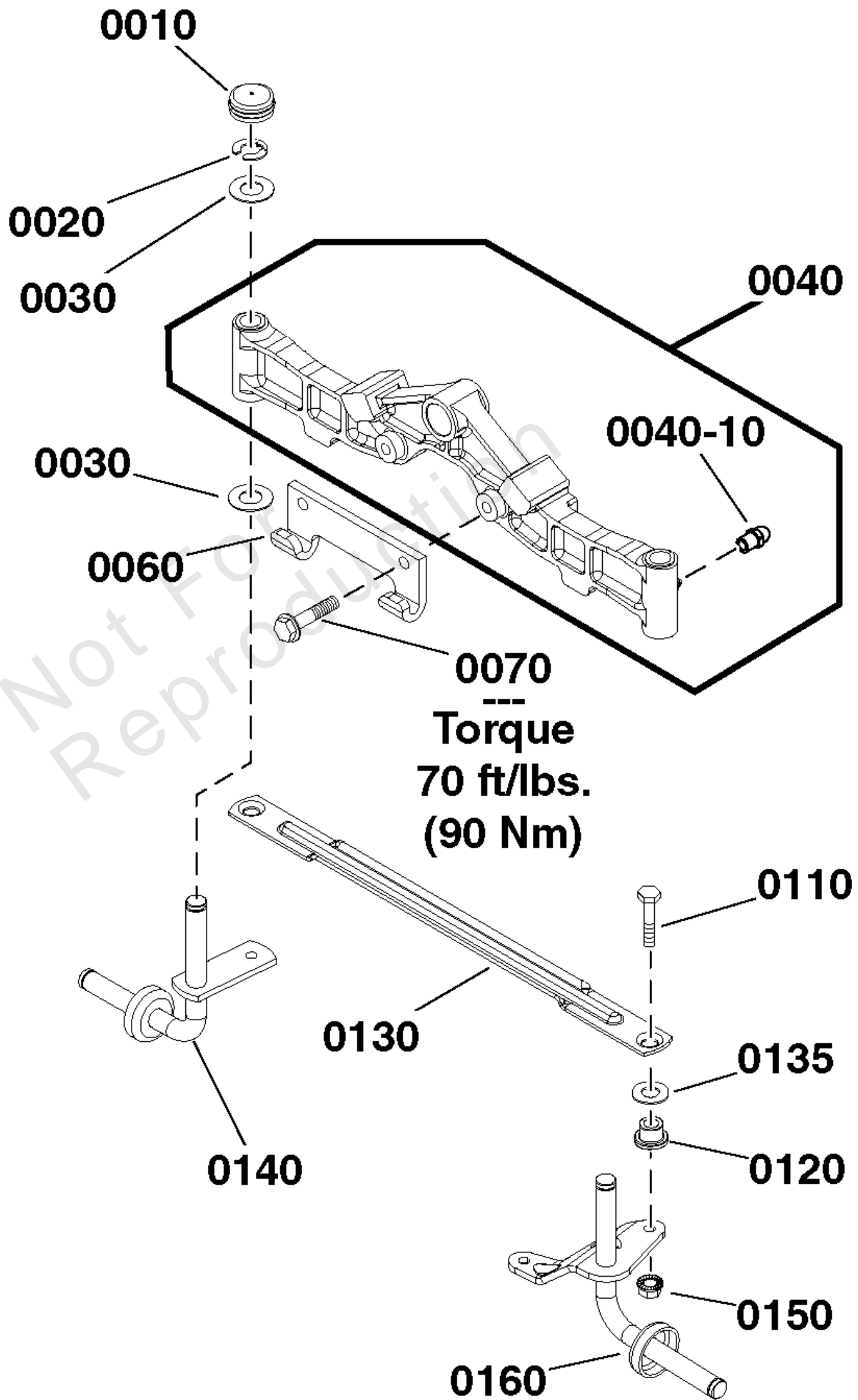

Front Axle Group

REF NO	PART NO	QTY	DESCRIPTION
0010	1734135SM	2	CAP, Hub
0020	1611710SM	2	E-RING, 3/4
0030	2860183SM	4	WASHER, Flat, 3/4
0040	1756386YP	1	AXLE, Front
0040-10	1704314SM	2	LUBE FITTING, .250 DR -(Included with Ref. No. 0040)
0060	1721918ASM	1	HOOK, Mower, Hitch
0070	1960652SM	2	SCREW, Hex Flange, Whiz Lock, 7/16-14 x 1-1/2
0110	1960032SM	2	SCREW, Hex Head, 3/8-16 x 1 1/4
0120	1731912SM	2	BUSHING, 3/8 ID x 5/8 OD x 1/2
0130	1751964YP	1	TIE ROD
0135	1960703SM	2	WASHER, 5/8
0140	1727872ASM	1	SPINDLE ASSEMBLY, R.H.
0150	703893	2	NUT, CNTR LCK, 3/8-16
0160	1751922YP	1	SPINDLE ASSEMBLY, L.H.

Not For Reproduction

Hood, Grille & Dash Group

Note: Unless noted otherwise, use the standard torque specifications

Mfg. No: 2691664-01

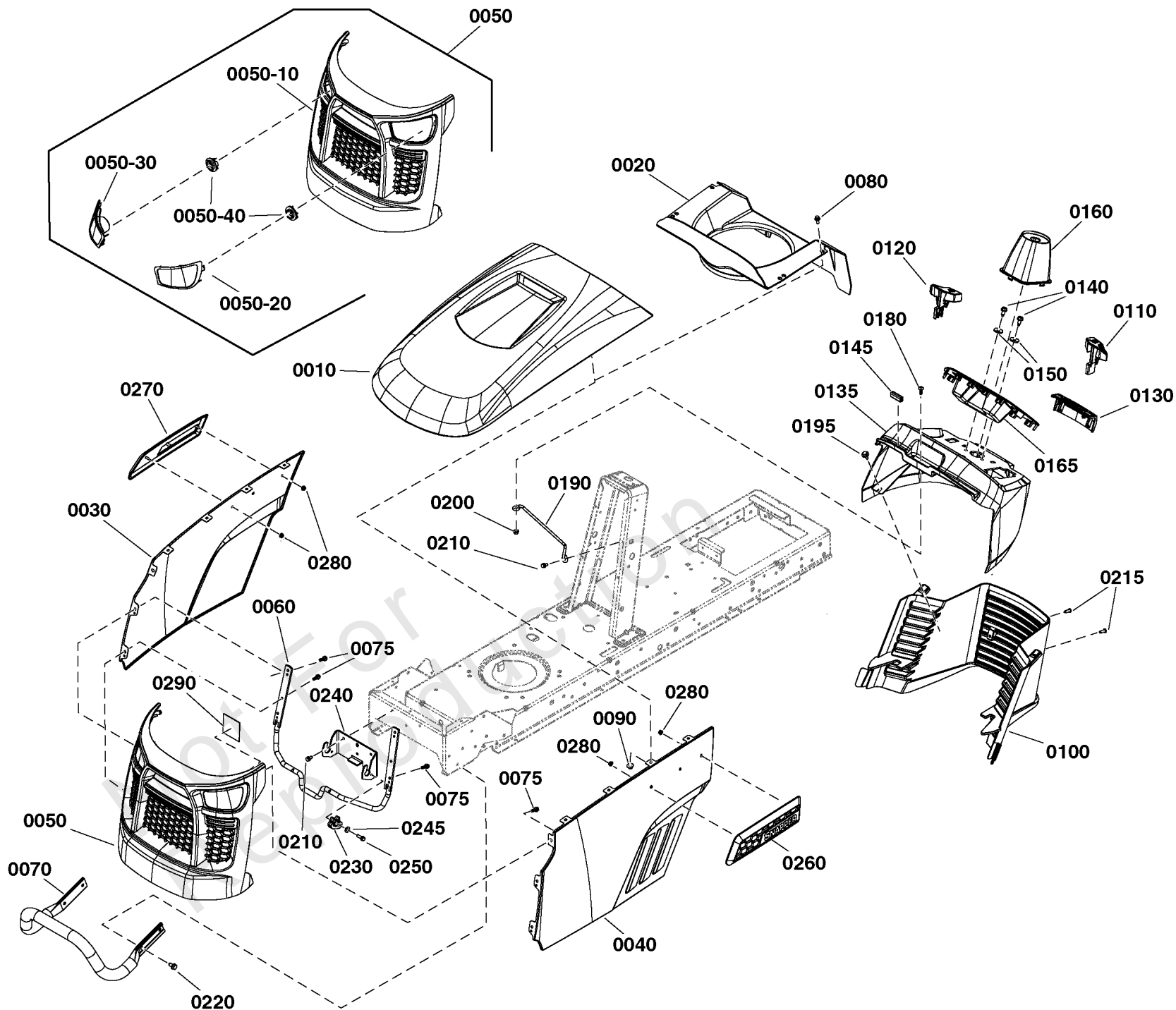

Hood, Grille & Dash Group

REF NO	PART NO	QTY	DESCRIPTION
0010	1728031DSM	1	HOOD, with Scoop
0020	7102326YP	1	AIR DUCT, Plenum
0030	1761214DYP	1	PANEL, Side RH
0040	1761215DYP	1	PANEL, Side, LH
0050	1761263YP	1	GRILLE -(Incl. Ref. Nos. 0050-10, 0050-20, 0050-30 & 0050-40)
0050-10	1761175YP	1	GRILLE, Front -(Included with Ref. No. 0050)
0050-20	1761333YP	1	HEADLIGHT, LH -(Included with Ref. No. 0050)
0050-30	1761334YP	1	HEADLIGHT, RH -(Included with Ref. No. 0050)
0050-40	1760239YP	2	LED HEADLIGHT AND SOCKET ASSEMBLY -(Included with Ref. No. 0050)
0060	1761070YP	1	ROD, Hood Hinge
0070	1761254DYP	1	BUMPER, Tube
0075	706369	6	SCREW, Hex Washer Head, 1/4-10 x 3/4
0080	1960295SM	8	CAPSCREW, Hex Flange, Whiz Lock, 1/4-20 x 5/8
0090	703161	8	NUT
0100	1761508YP	1	LOWER DASH ASSEMBLY
0110	1761401YP	1	KNOB, Parking Brake
0120	1761402YP	1	KNOB, Cruise
0130	1761510YP	1	DECORATIVE TRIM
0135	1761253YP	1	DASH, Upper
0140	703228	2	SCREW, 5/16-18 X .75
0145	1761773YP	2	EDGING, Rubber
0150	703298	2	WASHER, 5/16
0160	1761399YP	1	COVER, Steering Shaft
0165	1761464YP	1	DASH BEZEL
0180	770135	1	SCREW
0190	1761481YP	1	ROD, Dash Support
0195	2860664SM	2	SCREW, HEX SEMS WSHR,
0200	703463	1	NUT, GR5, 1/4-20
0210	704130	4	SCREW, HEX, 1/4-20X.5
0215	1960556SM	2	SCREW, Pan Head Torx, Taptite, 1/4-20 x 3/4
0220	703985	4	SCREW, 5/16-18X.5
0230	1761068YP	2	CLIP, Hood Hinge
0240	1761212CJYP	1	BRACKET, Hood Hinge
0245	703332	2	WASHER
0250	703466	2	BOLT, GR5, 1/4X.0750
0260	1761342YP	1	BADGE, Snapper, LH
0270	1761343YP	1	BADGE, Snapper, RH
0280	189164GS	4	PALNUT, 3/16
0290	1761818YP	1	INSULATION, Thermal

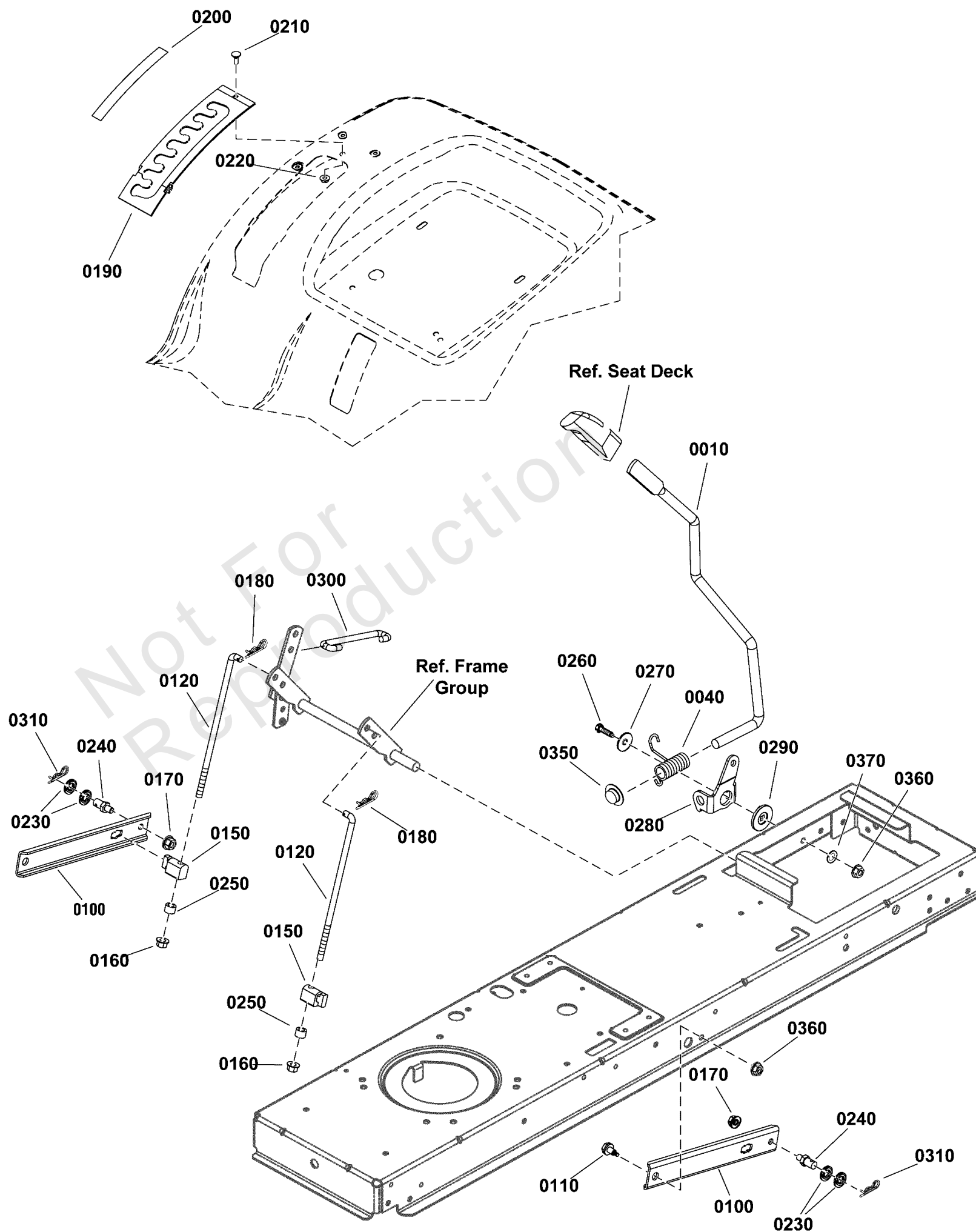

Lift Group - Manual

REF NO	PART NO	QTY	DESCRIPTION
0010	1728070SM	1	ROD, Lift Handle, 18-7/8"
0040	1729652SM	1	SPRING, Torsion
0100	1731417SM	2	ARM, Rear Lift
0110	1732426SM	2	BOLT-SHLDR 5/16-18 0.
0120	1727955SM	2	ROD, Lift, Lower, 3/8 x 10 Long
0150	1731894SM	2	TRUNNION
0160	1960687SM	2	NUT, Hex Flange Nylock, ESNA, 3/8-16
0170	1931211SM	2	NUT, Hex Flange Whiz Lock Small, 3/8-16
0180	703300	2	PIN, 3/32 X 1.6
0190	1727985SM	1	QUADRANT, Lift Height
0200	1730264SM	1	DECAL, Height Of Cut
0210	1960252SM	1	BOLT-RD HD SH SQ NK 1
0220	1930641SM	1	NUT, Hex Flange Whiz Lock, 1/4 - 20
0230	1960170SM	4	WASHER, 1/2 x 1 OD
0240	094067MA	2	PIN, Threaded, Shoulder, 3/8-16 x 1-7/16 Long
0250	1666294SM	2	SPACER, .385 ID x .6697 OD x .455 Long
0260	84003606	1	SCREW
0270	1933468SM	1	WASHER, 5/16 x 1-1/4 OD
0280	1728990ASM	1	CLEVIS, Lift
0290	1727935SM	1	SPACER-PIVOT 0.330ID
0300	1727954SM	1	ROD, Lift .375 dia
0310	703796	2	PIN, Hair
0350	771009	1	PUSHNUT, 5/8
0360	703115	3	NUT
0370	703298	1	WASHER, 5/16

Seat Deck & Fuel Tank Group

Note: Unless noted otherwise, use the standard torque specifications

Mfg. No: 2691664-01

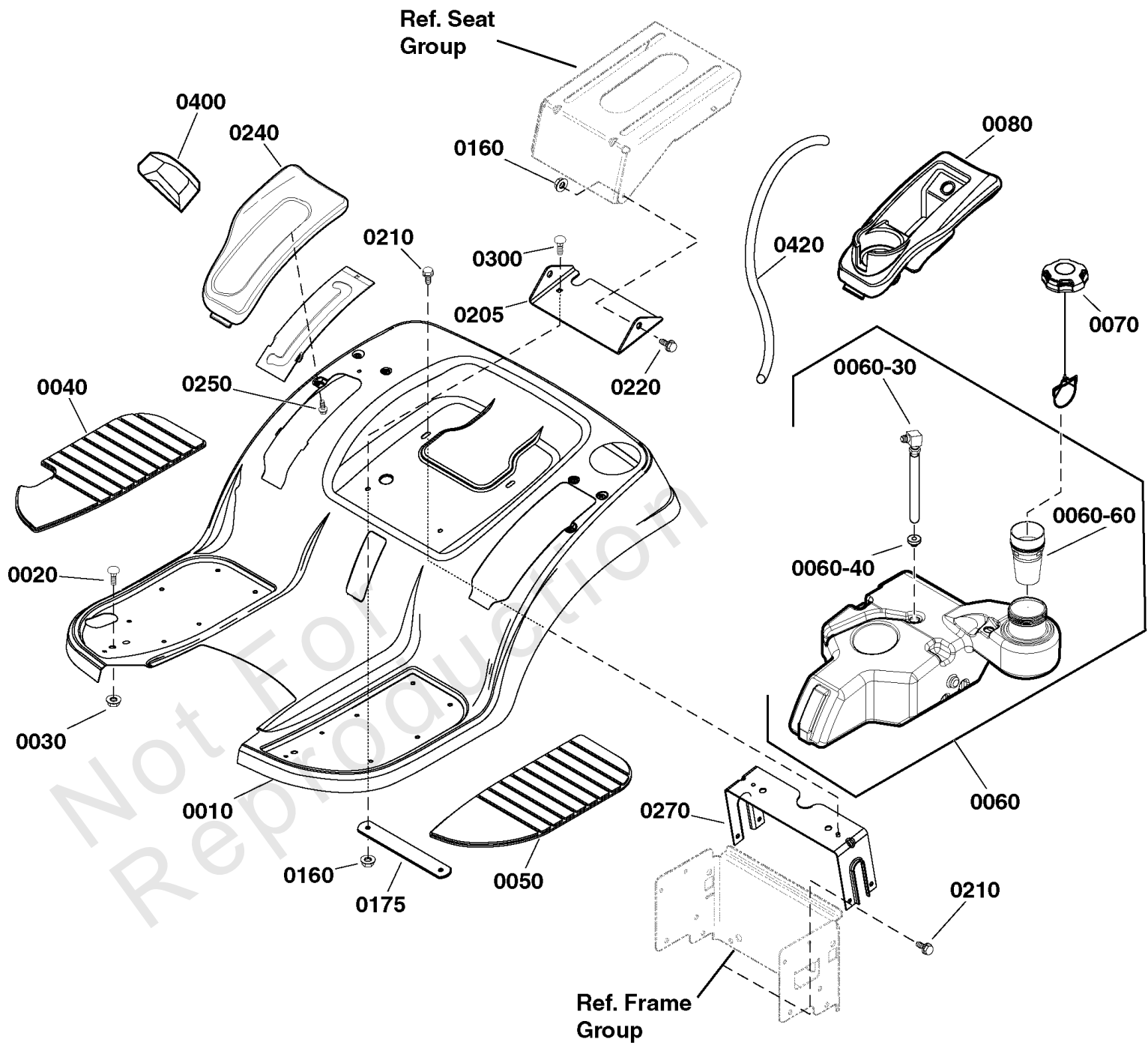

Seat Deck & Fuel Tank Group

REF NO	PART NO	QTY	DESCRIPTION
0010	1727264DSM	1	SEAT DECK
0020	703185	2	BOLT, Round Head, Short Square Neck
0030	703409	2	NUT, 5/16-18, GR5
0040	1728007SM	1	PAD, Footrest, R.H.
0050	1728006SM	1	PAD, Footrest, L.H.
0060	1751226YP	1	TANK, Fuel -(Includes Ref. Nos. 0060-30, 0060-40 & 0060-60)
0060-30	1736609YP	1	FITTING & HOSE ASSEMBLY, Fuel Tank
0060-40	1654930SM	1	BUSHING, Fuel Tank
0060-60	-----	1	DROP TUBE -(Not Serviceable. Order Ref. Nos. 0060)
0070	1761224YP	1	CAP, Fuel
0080	1739535YP	1	POD, L.H.
0160	703115	2	NUT
0175	1759177CJYP	1	BRACKET, Support, Seat Pivot
0205	1757755BMYP	1	SUPPORT, Seat Pivot
0210	703949	6	SCREW, 5/16-18.625
0220	703851	2	BOLT, 5/16-18X1.15
0240	1739537YP	1	POD, R.H.
0250	1960536SM	6	SCREW, HEX WSHR HD PL
0270	1731310SM	1	SUPPORT, Seat Deck
0300	704065	2	BOLT, 5/16-18X.875
0400	1722302SM	1	GRIP
0420	7700552X91YP	1	HOSE, VAPOR, 91" -(Cut to Length)
0440	703586	2	TIE, SELF LOCKING

Seat Group

Note: Unless noted otherwise, use the standard torque specifications

Mfg. No: 2691664-01

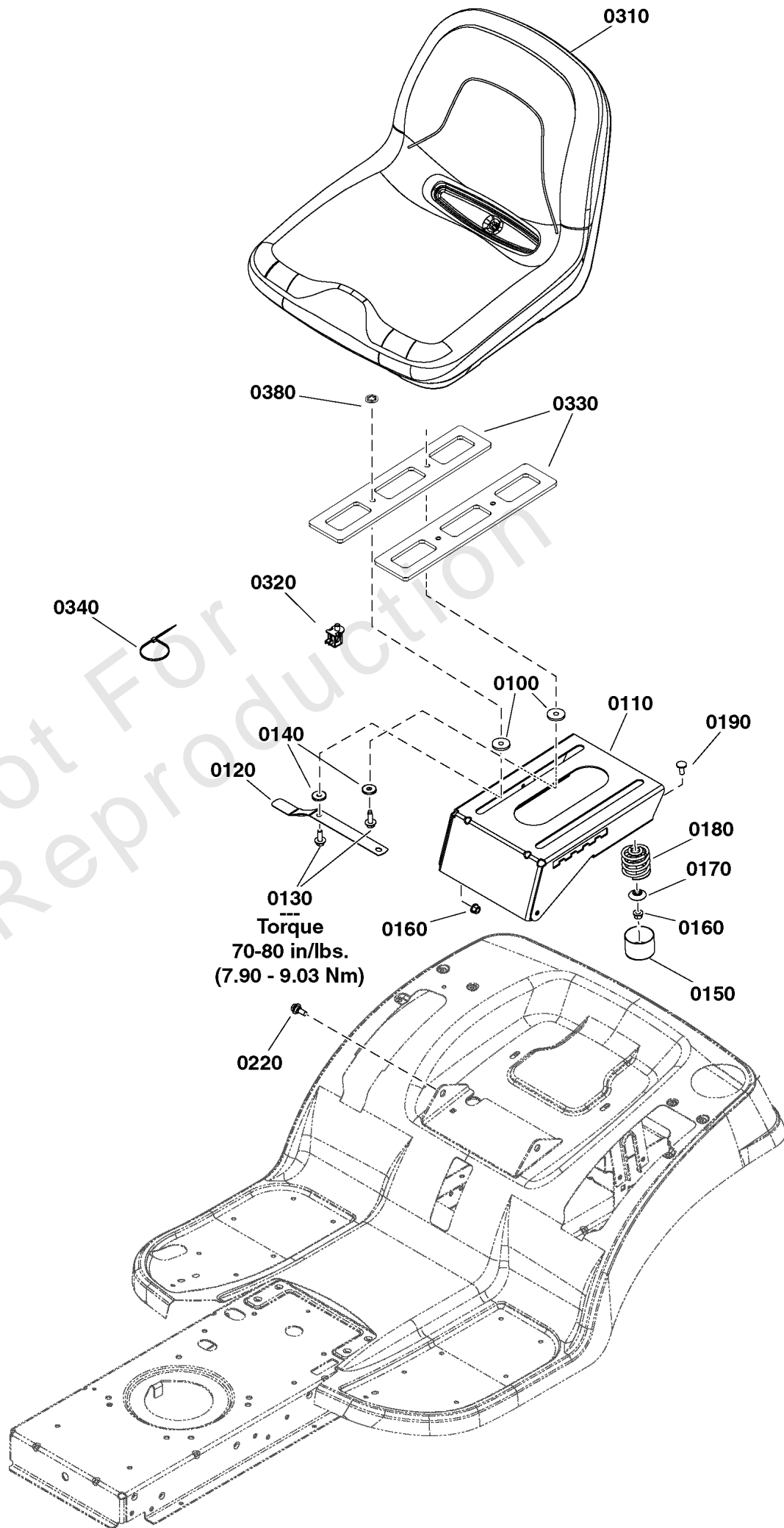

Seat Group

REF NO	PART NO	QTY	DESCRIPTION
0100	1731300SM	4	SPACER, 5/16 ID x 1-1/4 OD x 5/16"
0110	1755767BMYP	1	SUPPORT, Seat
0120	1727268BMYP	1	LATCH, Seat
0130	1933689SM	4	SCREW, 5/16-18 x 1-1/2, Hex Flange, Whiz Lock
0140	703298	4	WASHER, 5/16
0150	1704724SM	2	COVER, Spring, 1-1/2"
0160	703115	4	NUT
0170	1709256SM	2	WASHER, Spring, 5/16 x 1 1/4
0180	1704728SM	2	SPRING, Compression, 2"
0190	703225	2	BOLT
0220	703851	2	BOLT, 5/16-18X1.15
0310	84003944	1	SEAT, 15"
0320	7023354YP	1	SWITCH, SEAT
0330	84003652	2	SPACER, Plate
0340	703586	1	TIE, SELF LOCKING
0380	703297	4	RETAINER, GR5, 5/16

Not For Reproduction

Steering Group

Note: Unless noted otherwise, use the standard torque specifications

Mfg. No: 2691664-01

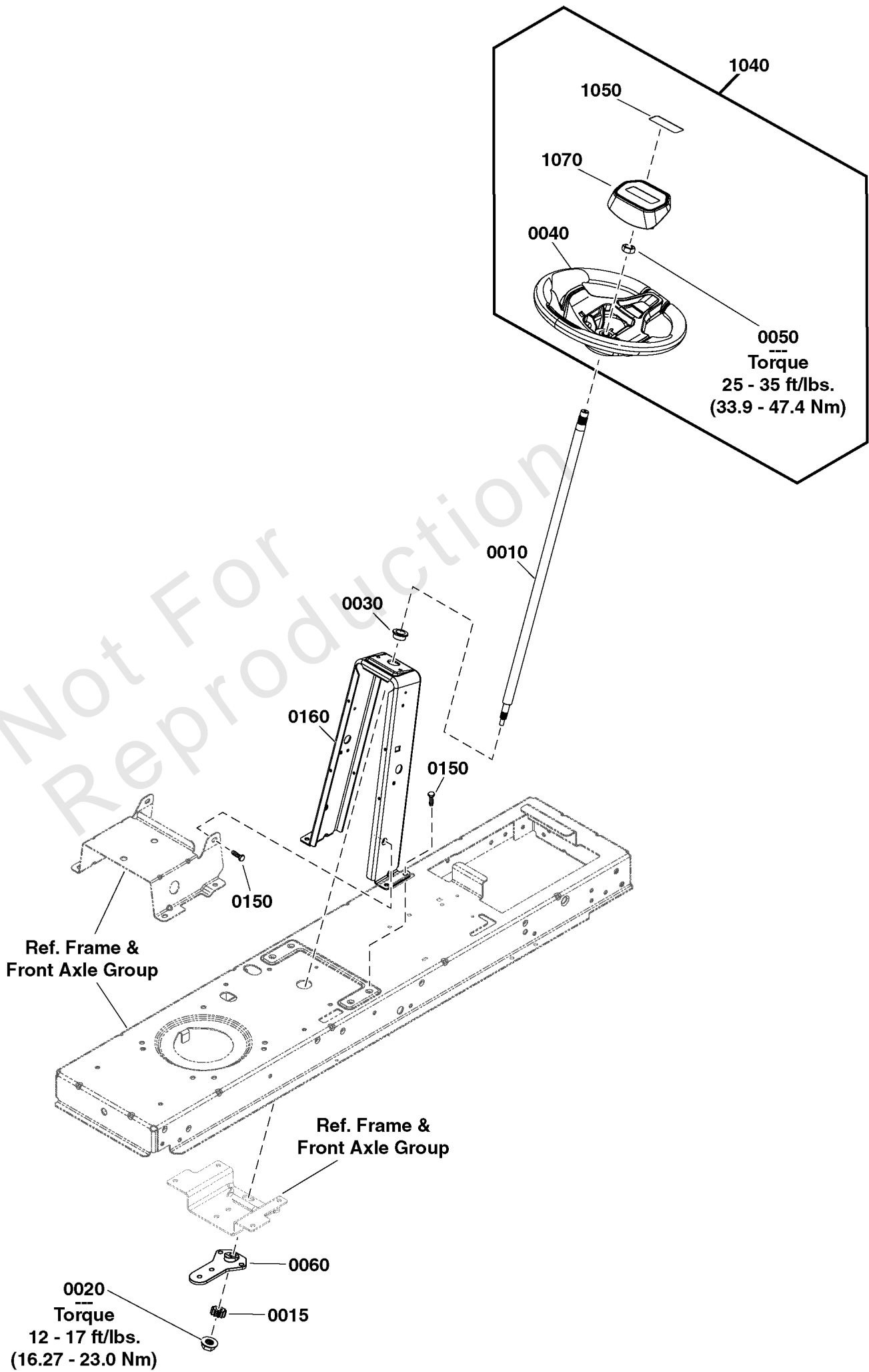

Steering Group

REF NO	PART NO	QTY	DESCRIPTION
0010	1761012YP	1	SHAFT, Steering
0015	1761013YP	1	GEAR, Pinion
0020	703115	1	NUT
0030	1729665SM	1	BUSHING, Steering, 3/4 ID
1040	84001121	1	KIT, Steering Wheel, Snapper -(Incl. Ref. Nos. 0040, 0050, 1050 & 1070)
0040	-----	1	STEERING WHEEL
0050	1960576SM	1	NUT, Hex Lock, ESNA Light, 5/8-18
1050	84002249	1	DECAL, Snapper Logo, 3.1" X .8"
1070	84002250	1	CAP, Steering Wheel
0060	1761010YP	1	SUPPORT, Steering
0150	703949	6	SCREW, 5/16-18.625
0160	1761498CJYP	1	TOWER, Steering

Not For Reproduction

Transmission Group

Note: Unless noted otherwise, use the standard torque specifications

Mfg. No: 2691664-01

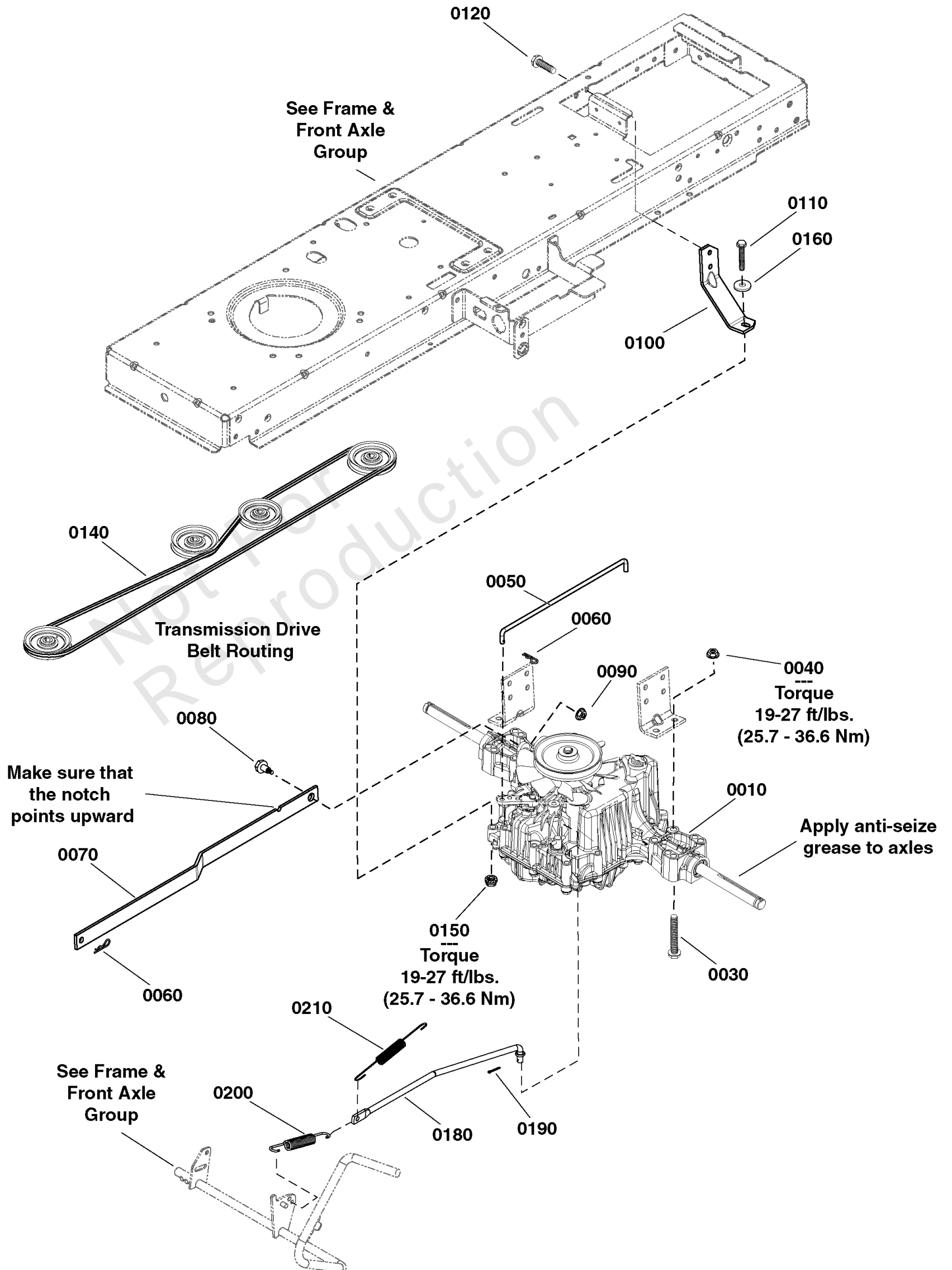

Transmission Group

REF NO	PART NO	QTY	DESCRIPTION
0010	1761324YP	1	TRANSMISSION ASSEMBLY, Tuff Torque, K46BP
0030	1960586SM	4	CAPSCREW, Hex Flange, Whiz Lock, 5/16-18 x 2-1/2
0040	1931277SM	4	NUT, Hex Flange Whiz Lock Small, 5/16-18
0050	1728120SM	1	ROD, Bypass, 1/4 x 11 7/16
0060	1722460SM	2	PIN, Hair
0070	1727258ASM	1	ARM, Control
0080	1732426SM	1	BOLT-SHLDR 5/16-18 0.
0090	1935048SM	1	NUT, Hex Flange, Two Way Lock, 5/16-18
0100	1728043ASM	1	STRAP, Torque 7 GA
0110	1922127SM	1	SCREW, Hex Head Cap, 5/16-18 x 1 3/4
0120	1664847SM	1	SCREW, Taptite, 5/16-18 x 3/4
0140	1728008SM	1	V-BELT, HA, 89-1/4" Long
0150	1960686SM	1	NUT, Hex Flange Nylock, 5/16-18
0160	1919381SM	1	WASHER, Flat, .34 ID x 1" OD
0180	1727253SM	1	ROD, Brake, 3/8 Dia. x 15-1/8 Long
0190	1918447SM	1	PIN, Cotter, 15/16 x 3/4
0200	1731262SM	1	SPRING, Extension, 11/16 x 3-3/8
0210	1721995SM	1	SPRING, Extension, 5/8 x 6-5/8

Not For Reproduction

Transmission SERVICE PARTS - Tuff Torq K46BP (1729588)

Note: Unless noted otherwise, use the standard torque specifications

Mfg. No: 2691664-01

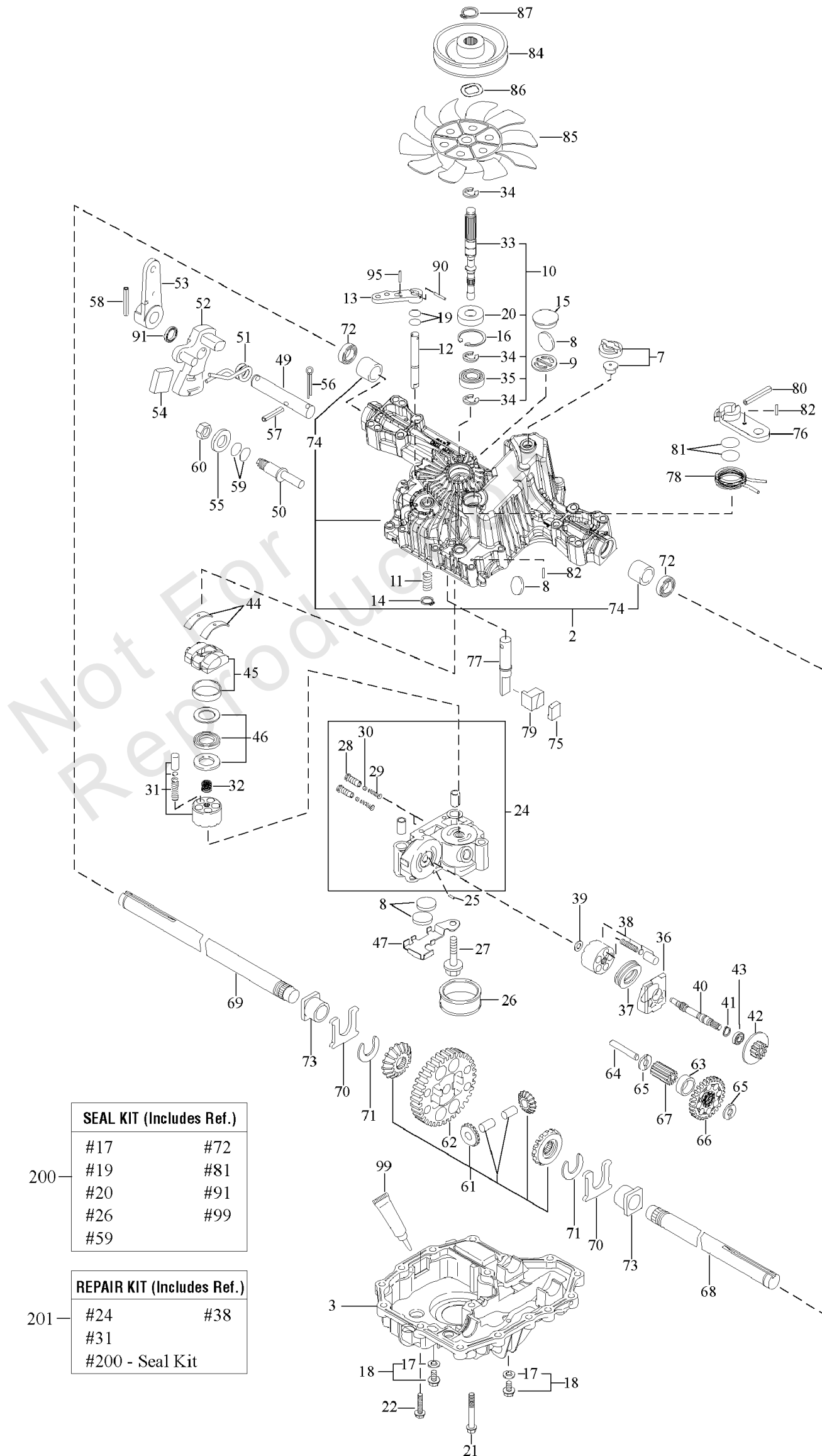

SEAL KIT (Includes Ref.)	
#17	#72
#19	#81
#20	#91
#26	#99
#59	

200

REPAIR KIT (Includes Ref.)	
#24	#38
#31	
#200 - Seal Kit	

201

Transmission SERVICE PARTS - Tuff Torq K46BP (1729588)

REF NO	PART NO	QTY	DESCRIPTION
1	1729588SM		TRANSMISSION ASSEMBLY, Tuff Torque, K46BP
2	-----		*KIT, Upper Case
3	-----		*LOWER CASE
7	1718052SM		VENT VALVE 15
8	1724279SM		MAGNET
9	-----		*MAGNET HOLDER
10	-----		*PUMP SHAFT/BEARING KIT
11	-----		SPRING 25
12	1724281SM		BYPASS SHAFT A
13	1720418SM		LEVER, Bypass
14	1718061SM		RING, Snap, 10
15	1724282SM		SEALING CAP, 30
16	1708650SM		RING, Snap, C 35
17	1724323YP		SEAL WASHER, 8
18	-----		KIT, Drain Bolt
21	-----		SCREW, Tapping, 8 * 55
22	1707789SM		SCREW, Tapping, 8 * 30
24	-----		CENTER CASE E W/BALL IDS SERVICE KIT
25	1718070SM		PIN, 3 * 9.8
26	-----		FILTER 105
27	1720805SM		BOLT, 10 * 75
28	-----		IDS VALVE 1.0
29	1724287SM		IDS SPRING
30	-----		BALL, 3/16
31	-----		KIT, Cylinder Block (Pump)
32	1724290SM		SPRING
33	1739892YP		PUMP SHAFT
34	1718076SM		E-RING, 15
35	1708673SM		BEARING, 6202C3
36	1718077SM		MOTOR HOUSING
37	-----		THRUST BEARING 51106
38	1718079SM		KIT, Cylinder Block
39	1718084SM		WASHER, 12 * 24 * 1
40	1724943SM		MOTOR SHAFT
41	1708672SM		RING, Snap, S15
42	1724294SM		BRAKE DISC/MOTOR GEAR (11T)
43	-----		BEARING, 6202 RSR C3
44	1718089SM		THRUST METAL
45	-----		SWASH PLATE CMP
46	1718086SM		THRUST BEARING K81105
49	-----		CONTROL SHAFT
50	-----		FULCRUM
51	-----		SPRING, Torsion
52	-----		CONTROL ARM A
53	1724347SM		CONTROL LEVER C
54	-----		JERKY PLATE
55	1708689SM		WASHER, 12
56	1724349SM		COTTER PIN, 1/8 * 3/4

Footnotes:

Note* See your local authorized dealership for Tuff Torq parts and warranty or contact Tuff Torq at www.tufftorqservices.com (1-866-572-3441 US only / 01-423-585-1977)

Note* See your local authorized dealership for Tuff Torq parts and warranty or contact Tuff Torq at www.tufftorqservices.com (U.S. 1-866-572-3441 / Int'l: 01-423-585-1977)

Transmission SERVICE PARTS - Tuff Torq K46BP (1729588)

Note: Unless noted otherwise, use the standard torque specifications

Mfg. No: 2691664-01

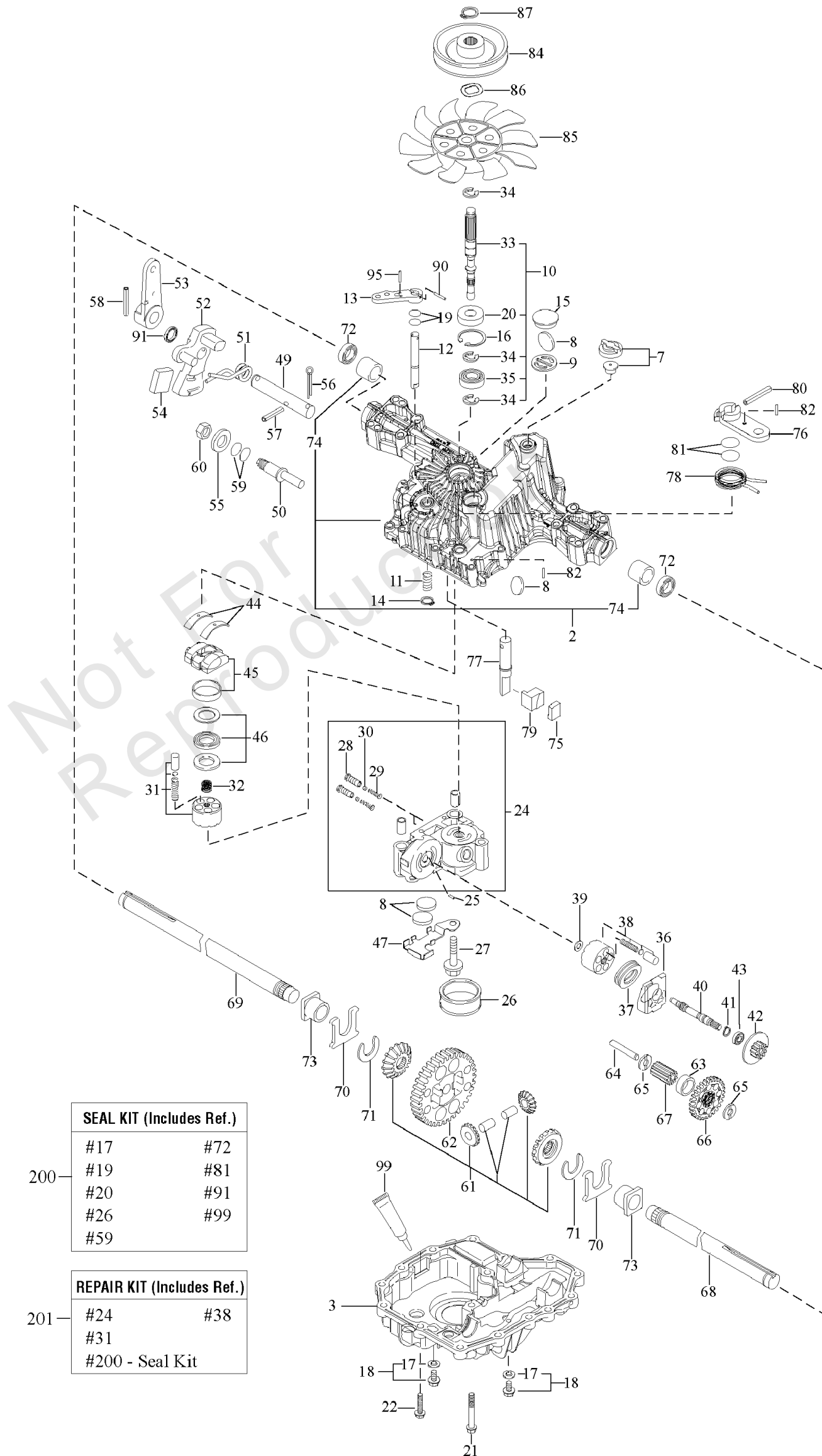

Transmission SERVICE PARTS - Tuff Torq K46BP (1729588)

REF NO	PART NO	QTY	DESCRIPTION
57	1724296SM		SPRING PIN 6 * 36
58	1718100SM		ROLL PIN 6 * 40
60	1708692SM		NUT 12
61	-----		*KIT, Differential Gear
62	-----		*FINAL GEAR (54T)
63	-----		*FINAL PINION COLLAR
64	-----		*REDUCTION SHAFT
65	1724948SM		WASHER, 12 * 32 * 3.2
66	-----		*REDUCTION GEAR (37T)
67	-----		*FINAL PINION GEAR (10T)
68	1724303SM		AXLE SHAFT, Left
69	1724304SM		AXLE SHAFT, Right
70	-----		*THRUST WASHER
71	1718113SM		RING, 17
72	1718111SM		SEAL, 19 * 32 * 8 -(For this part only contact B&S Tech support)
73	1718110SM		BUSHING, 19 * 25
74	-----		*BUSHING, 19.05
75	1724305SM		BRAKE SHOE
76	1724306SM		BRAKE LEVER
77	-----		*BRAKE SHAFT
78	-----		*BRAKE RETURN SPRING
79	1724309SM		BRAKE ACTUATOR
80	1724310SM		SPRING PIN, 5 * 32
82	1724311SM		SPRING PIN 4 * 16
84	1732918SM		PULLEY D
85	1724314SM		FAN, White
86	1724315SM		WASHER, Wave
87	1724316SM		RING, Snap
90	-----		*SPRING PIN 3.0A * 20
95	-----		*SPRING PIN 3.0A * 16
99	-----		*SEALANT
200	1727541YP		K46 & T40 SEAL KIT
201	-----		*REPAIR KIT K46

Footnotes:

Note* See your local authorized dealership for Tuff Torq parts and warranty or contact Tuff Torq at www.tufftorqservices.com (1-866-572-3441 US only / 01-423-585-1977)

Note* See your local authorized dealership for Tuff Torq parts and warranty or contact Tuff Torq at www.tufftorqservices.com (U.S. 1-866-572-3441 / Int'l: 01-423-585-1977)

Wheels & Tires

Note: Unless noted otherwise, use the standard torque specifications

Mfg. No: 2691664-01

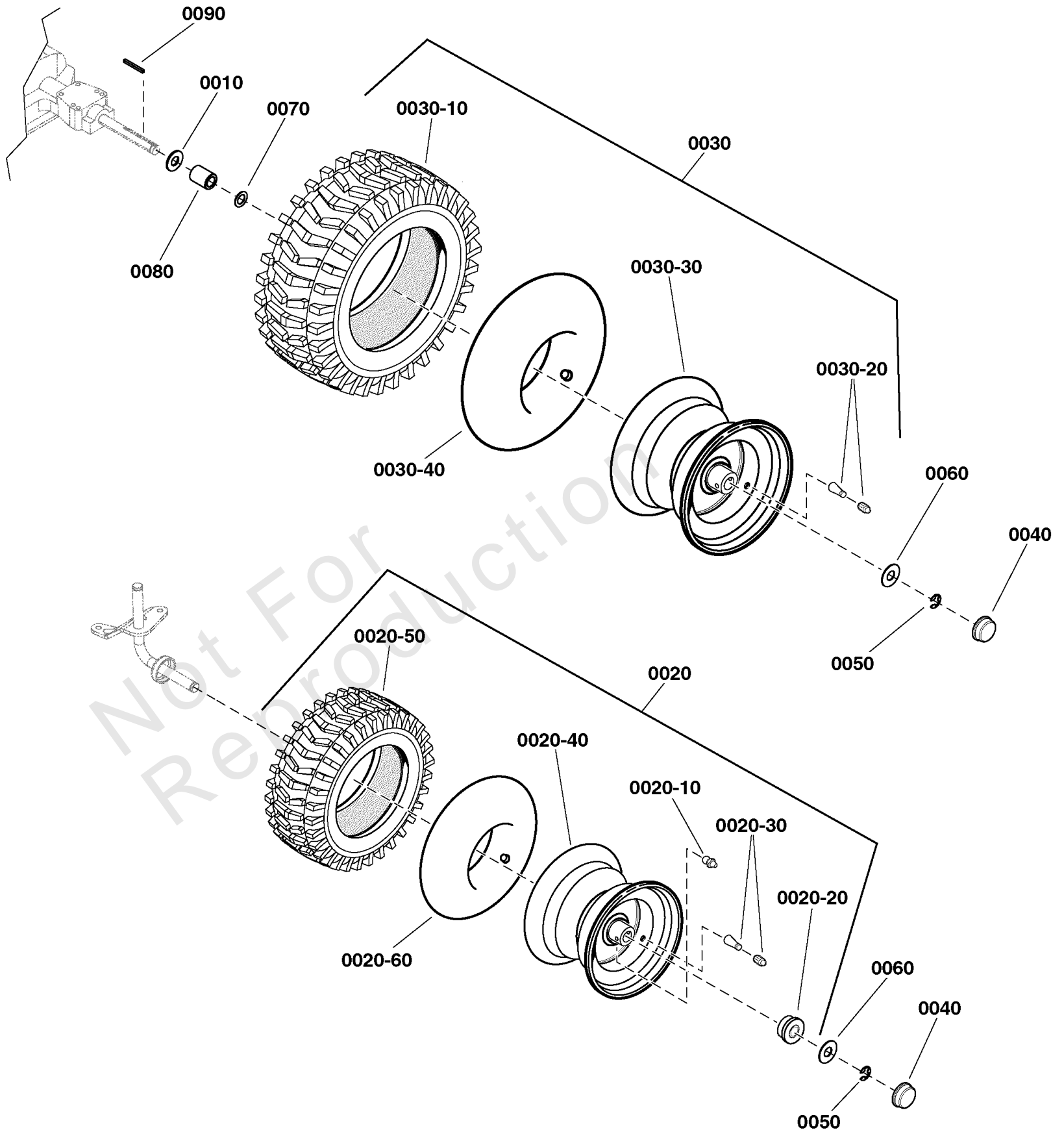

Wheels & Tires

REF NO	PART NO	QTY	DESCRIPTION
0010	2860202SM	1	WASHER, 3/4 x 1-5/8 OD x 1/8 Thick
0020	1761503YP	1	WHEEL AND TIRE ASSEMBLY, Front, 15 x 6-6
0020-10	84003425	1	ZERK, Grease Fitting
0020-20	84003424	1	BEARING, Ball
0020-30	2172353SM	1	VALVE STEM & CAP
0020-40	-----	1	Rim -(Refer to Note: *)
0020-50	7101556YP	1	TIRE, 15 x 6 2 Ply K358
0020-60	1664090SM	1	TUBE, Tire, Front
0030	7101563YP	1	ASSY, WHEEL & TIRE
0030-10	7101562YP	2	TIRE, 20 x 10-8, 2 Ply K358
0030-20	2172353SM	1	VALVE STEM & CAP
0030-30	-----	1	RIM -(Refer to Note: *)
0030-40	2164247SM		TUBE, Tire, Rear
0040	094618MA	4	HUB CAP
0050	2827794SM	4	KLIPRING, .75 Dia Shaft
0060	17X195MA	4	WASHER, Flat 1-3/4
0070	17X160MA	2	WASHER, Flat, 3/4 x 1-1/4 x 16
0080	1730181SM	2	SPACER, 3/4 ID x 1-1/4 OD x 1-5/8
0090	021553MA	2	KEY, Square, 3/16

Not For
Reproduction

Footnotes:

Note* Not a serviceable part, service wheel complete

Hardware Identification & Torque Specifications

Torque Specification Chart								
FOR STANDARD METRIC MACHINE HARDWARE (Tolerance ± 20%)								
Property Class	5.6		8.8		10.9		12.9	
	Class 5.6		Class 8.8		Class 10.9		Class 12.9	
Size Of Hardware	in/lbs	Nm.	in/lbs	Nm.	in/lbs	Nm.	in/lbs	Nm.
	ft/lbs		ft/lbs		ft/lbs		ft/lbs	
M3	5.88	.56	13.44	1.28	19.2	1.80	22.92	2.15
M4	13.44	1.28	30.72	2.90	43.44	4.10	52.56	4.95
M5	26.4	2.50	60.96	5.75	5.97	8.10	7.15	9.7
M6	44.64	4.3	7.3	9.9	10.3	14	12.1	16.5
M7	5.2	7.1	12.1	16.5	16.9	23	19.9	27
M8	7.7	10.5	17.7	24	25	34	29	40
M10	15	21	35	48	50	67	59	81
M12	26	36	61	83	86.2	117	103	140
M14	42	58	101	132	136	185	162	220
M16	64	88	147	200	210	285	250	340
M18	89	121	202	275	287	390	346	470
M20	126	171	290	390	405	550	486	660
M22	169	230	390	530	559	745	656	890
M24	217	295	497	375	708	960	840	1140
M27	320	435	733	995	1032	1400	1239	1680
M30	435	590	995	1350	1401	1900	1681	2280
M33	590	800	1349	1830	1902	2580	2278	3090
M36	759	1030	1740	2360	2441	3310	2935	3980
M39	988	1340	2249	3050	3163	4290	3798	5150

Torque Specification Chart						
FOR STANDARD MACHINE HARDWARE (Tolerance ± 20%)						
Hardware Grade	No Marks		SAE Grade 5		SAE Grade 8	
	SAE Grade 2		SAE Grade 5		SAE Grade 8	
Size Of Hardware	in/lbs	Nm.	in/lbs	Nm.	in/lbs	Nm.
	ft/lbs		ft/lbs		ft/lbs	
8-32	19	2.1	30	3.4	41	4.6
8-36	20	2.3	31	3.5	43	4.9
10-24	27	3.1	43	4.9	60	6.8
10-32	31	3.5	49	5.5	68	7.7
1/4-20	66	7.6	8	10.9	12	16.3
1/4-28	76	8.6	10	13.6	14	19.0
5/16-18	11	15.0	17	23.1	25	34.0
5/16-24	12	16.3	19	25.8	29	34.0
3/8-16	20	27.2	30	40.8	45	61.2
3/8-24	23	31.3	35	47.6	50	68.0
7/16-14	30	40.8	50	68.0	70	95.2
7/16-20	35	47.6	55	74.8	80	108.8
1/2-13	50	68.0	75	102.0	110	149.6
1/2-20	55	74.8	90	122.4	120	163.2
9/16-12	65	88.4	110	149.6	150	204.0
9/16-18	75	102.0	120	163.2	170	231.2
5/8-11	90	122.4	150	204.0	220	299.2
5/8-18	100	136	180	244.8	240	326.4
3/4-10	160	217.6	260	353.6	386	525.0
3/4-16	180	244.8	300	408.0	420	571.2
7/8-9	140	190.4	400	544.0	600	816.0
7/8-14	155	210.8	440	598.4	660	897.6
1-8	220	299.2	580	788.8	900	1,244.0
1-12	240	326.4	640	870.4	1,000	1,360.0

The guides and ruler furnished below are designed to help you select the appropriate hardware.



Nut, M8

Thread Diameter (mm)

Inside Diameter (in) Threads per inch

Nut, 1/2-16



Screw, M8- 1.25 x 25

Thread Diameter (mm) Distance between threads (mm) Body Length (mm)

Body Diameter Threads per inch Body Length (in)

Screw, 1/2- 16 x 2



Standard Hardware Sizing

When a washer or nut is identified as 1/2" (M8), this is the *Nominal size*, meaning the *inside diameter* is 1/2 inch (8mm metric thread diameter); if a second number is present it represents the *threads per inch* (distance between threads).

When bolt or capscrew is identified as 1/2 - 16 x 2" (M8 - 1.25 x 50), this means the *Nominal size*, or body diameter is 1/2 inch (8mm metric thread diameter), the second number, 16, represents the *threads per inch*, (*distance between threads*). The final number is the body length of the bolt or screw, 2 inches (50mm).

NOTES

- These torque values are to be used for all hardware excluding: locknuts, self-tapping screws, thread forming screws, sheet metal screws and socket head setscrews.
- Recommended seating torque values for locknuts:
 - for prevailing torque locknuts - use 65% of grade 5 torques.
 - for flange whizlock nuts and screws - use 135% of grade 5 torques.
- Unless otherwise noted on assembly drawings, all torque values must meet this specification.

Common Hardware Types

Hex Head Capscrew

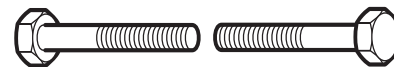

Washer

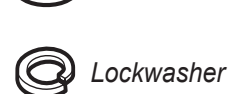

Carriage Bolt

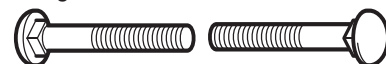

Hex Nut

Wrench & Fastener Size Guide

1/4" Bolt or Nut Wrench—7/16"	5/16" Bolt or Nut Wrench—1/2"	3/8" Bolt or Nut Wrench—9/16"	7/16" Bolt or Nut Wrench (Bolt)—5/8" Wrench (Nut)—11/16"	1/2" Bolt or Nut Wrench—3/4"
M6 Bolt or Nut Wrench—10mm	M8 Bolt or Nut Wrench—13mm	M10 Bolt or Nut Wrench—17mm	M12 Bolt or Nut Wrench—19mm	M14 Bolt or Nut Wrench—22mm

