



Parts Manual

Mfg. No: 2691499-00
ZT1936, 36" (91cm) Fabricated Mower
Deck, 19HP B&S , 360Z Series

1692125 - Cart, Dump (10 Cu. Ft.)
1687860 - Mesh Seat Kit.
1687810YP - Arm Rest Kit, 15" Plastic Seat.
1697103-00 - Cargo Bed Kit.
1697104-00 - Headlight Kit.
1697101-00 - Bagging Boot & Baffle, 36".
1697102-00 - Grass Mulcher Kit, 36".
1697106-00 - Grass Catcher Mounting Kit.
1697408A-00 - Kit, ZT Catcher, Twin, CS.

Not For
Reproduction

Model Components	Page
36" Mower Deck - Clutch & Support Group.....	4
36" Mower Deck - Housing, Arbors & Blades Group.....	6
Body & Fuel Tank Group.....	8
Controls Group.....	10
Decals Group (2992662).....	12
Electrical Group (80079600).....	14
Engine Group.....	16
Evap Group.....	18
Frame Group (2992584).....	20
Lift Group.....	22
Parking Brake Group (2991641).....	24
Seat Group.....	26
Transmission Group.....	28
Wheel & Tire Group.....	30
Torque Specification Chart.....	32

Not For
Reproduction

36" Mower Deck - Clutch & Support Group

Note: Unless noted otherwise, use the standard torque specifications

Mfg. No: 2691499-00

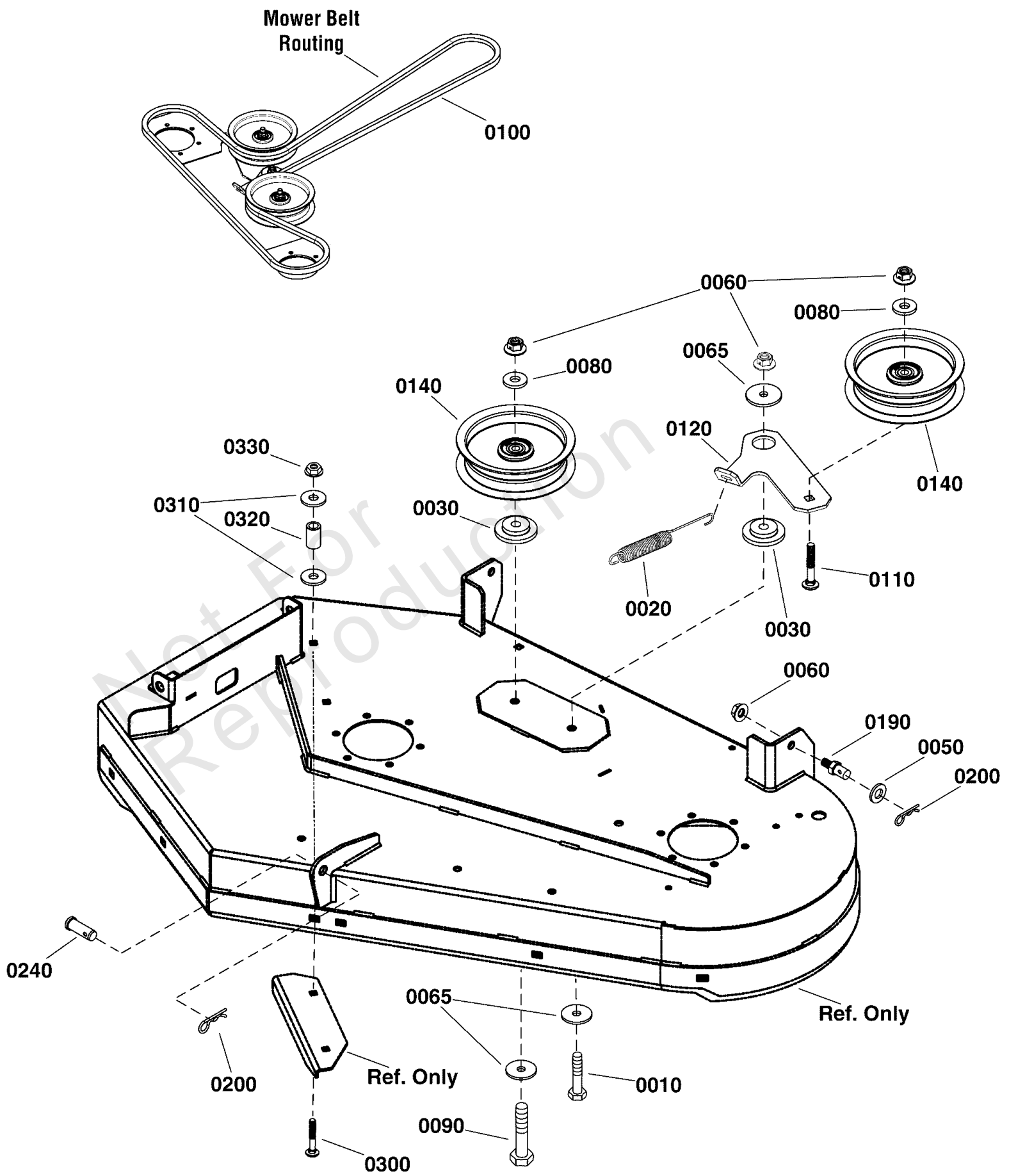

36" Mower Deck - Clutch & Support Group

REF NO	PART NO	QTY	DESCRIPTION
0010	703406	1	CAPSCREW,3/8-16X1.5
0020	1737415YP	1	SPRING, Extension
0030	706128	2	SPACER, IDLER
0050	703853	2	WASHER, 0.516IDX1OD
0060	703158	5	NUT, Hex Flange, 3/8-16
0065	5025305SM	3	WASHER, .41 X 1.75 X
0080	703878	2	WASHER, FLAT
0090	703133	1	HHCS,3/8-16X2.750
0100	84001701	1	BELT, Arbor
0110	7900009SM	1	RHSSNB, 3/8-16 X 2-1/
0120	84002223	1	ARM, Idler
0140	1757894YP	2	PULLEY, Flat Idler, 4.5"
0190	704054	2	PIN, 3/8-16
0200	703300	3	PIN, 3/32 X 1.6
0240	5025479YP	1	CLEVIS PIN, 1/2 X 1.3
0300	703175	1	BOLT,RD SH SQ
0310	703118	2	WASHER, Flat, 7/8, GR5
0320	5103660YP	1	SPACER, .32X.50 X.83
0330	703115	1	NUT

36" Mower Deck - Housing, Arbors & Blades Group

Note: Unless noted otherwise, use the standard torque specifications

Mfg. No: 2691499-00

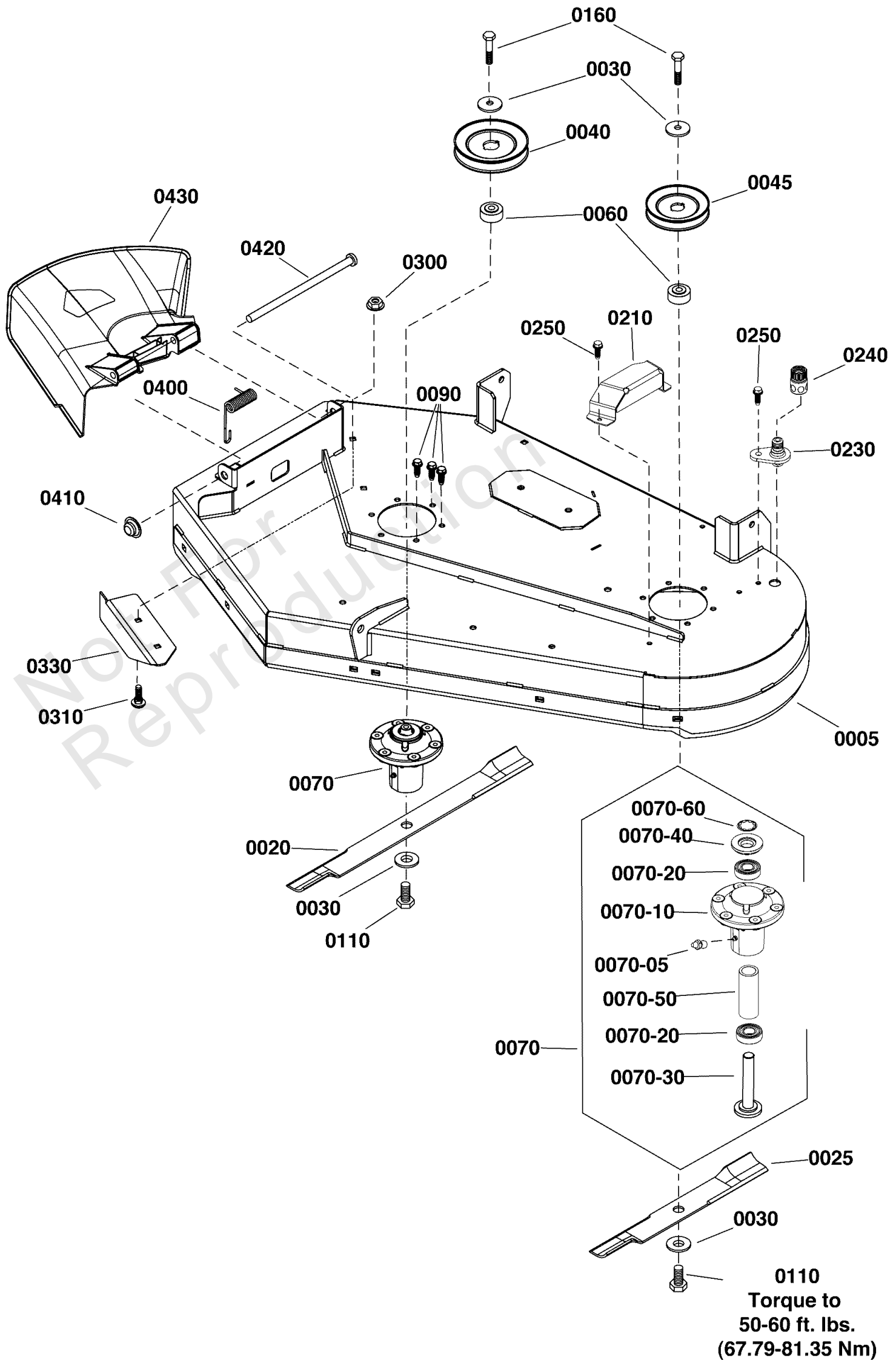

36" Mower Deck - Housing, Arbors & Blades Group

REF NO	PART NO	QTY	DESCRIPTION
0005	84001709	1	KIT, Mower Deck w/Decals, Orange
0005	84001710	1	KIT, Mower Deck w/Decals, Red
0020	84001711	1	BLADE, Mower, 22.24
0025	84001712	1	BLADE, Mower, 14.42
0030	1656916SM	4	WASHER, SPRING 0.475I
0040	1732953SM	1	PULLEY
0045	84002209	1	PULLEY, Spindle
0060	706362	2	SPACER, HUB
0070	84003172	2	ARBOR ASSEMBLY -(Includes Ref Nos. (0070-05 through 0070-60))
0070-05	1704314SM	1	LUBE FITTING, .250 DR
0070-10	84003653	1	HOUSING ASSEMBLY
0070-20	1735399YP	2	BEARING, Ball, 20mm
0070-30	84003165	1	SHAFT, Spindle
0070-40	84003166	1	COVER, ARBOR
0070-50	84003167	1	SPACER, BEARING
0070-60	1960766SM	1	RING, Self Locking
0090	704146	12	SCREW, HEX, 5/16-18X1
0110	1920676SM	2	CAPSCREW, Hex Head, 7/16-14 X 1
0160	1921212SM	2	CAPSCREW, Hex Head, 7/16-14 X 1 1/2
0210	84002211	1	COVER, Arbor
0230	1756247YP	1	ADAPTER, Washout Port
0240	1756246YP	1	CONNECTOR, Washout Port
0250	703228	3	SCREW, 5/16-18 X .75
0300	703115	1	NUT
0310	703185	1	BOLT, Round Head, Short Square Neck
0330	84002212	1	BAFFLE, Front, Discharge
0400	7035813SM	1	SPRING, TORSION, SIDE
0410	703179	1	PUSHNUT, CAP TYPE
0420	7104640YP	1	ROD, Deflector
0430	7104733YP	1	CHUTE, SIDE DISCHARGE

Body & Fuel Tank Group

Note: Unless noted otherwise, use the standard torque specifications

Mfg. No: 2691499-00

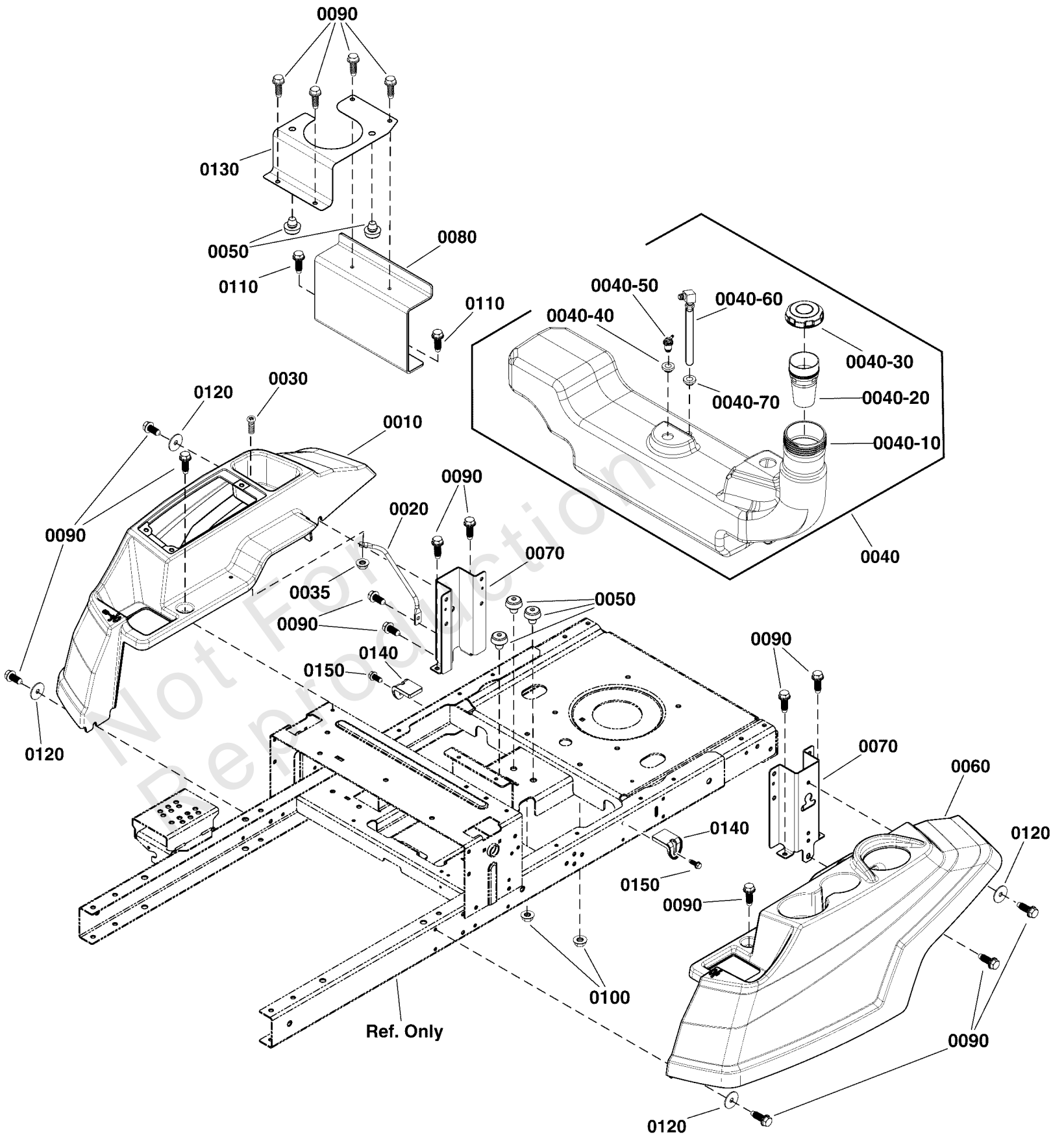

Body & Fuel Tank Group

REF NO	PART NO	QTY	DESCRIPTION
0010	84002190	1	FENDER, RH
0020	84002191	1	ROD, Fender
0030	770135	1	SCREW
0035	703463	1	NUT, GR5, 1/4-20
0040	84005279	1	FUEL TANK ASSEMBLY -(Incl. Ref. Nos, 0040-10 through 0040-70)
0040-10	-----	1	FUEL TANK -(Not a serviceable part. Order Ref Nos 0040)
0040-20	-----	1	TUBE, Fuel -(Not a serviceable part. Order Ref Nos 0040)
0040-30	1758314YP	1	CAP-FUEL TANK
0040-40	799624	1	GROMMET
0040-50	770046	1	REMOTE VENT ASSEMBLY
0040-60	1758927YP	1	TUBE-PICK UP
0040-70	1726400SM	1	BUSHING
0050	197546GS	5	MOUNT-VIBRATION
0060	84002192	1	FENDER, LH
0070	1758239AYP	2	SUPPORT-FENDER
0080	84002196	1	BRACKET
0090	703228	17	SCREW, 5/16-18 X .75
0100	703158	2	NUT, Hex Flange, 3/8-16
0110	704038	2	SCREW
0120	1960044SM	4	WASHER-0.312(0.33IDX1
0130	1759140AYP	1	STRAP-FUEL TANK
0140	84002197	2	SUPPORT, FUEL TANK
0150	703054	2	SCREW, 1/4-20X0.625

Controls Group

Note: Unless noted otherwise, use the standard torque specifications

Mfg. No: 2691499-00



Controls Group

REF NO	PART NO	QTY	DESCRIPTION
0010	1758372YP	2	HANDLE, CONTROL
0020	703115	4	NUT
0030	703483	4	BOLT,5/16-18X1.000,RO
0040	1757965YP	2	ARM, UPPER CONTROL
0050	707624	2	BOLT,SHLDR,5/16-18
0060	1757964YP	2	ARM, LOWER CONTROL
0070	2176440SM	4	BUSHING-0.765IDX
0080	703949	10	SCREW, 5/16-18.625
0090	1758087AYP	2	PIVOT, Inner Control
0100	5022308SM	2	BODY CLIP, 5/16-18 X
0110	1758373YP	2	KNOB, 5/16-18 X 2.5
0120	1650347SM	2	SPRING-COMP 0.50 IDX
0130	5025211SM	4	PIN, HAIR, .0585" X 1
0140	1758463YP	2	ROD, DAMPNER MNT
0150	84001625	2	DAMPENER
0160	1759182YP	2	LATCH, CONTROL ARM
0170	703101	4	BOLT,1/4-20X.75
0180	703463	4	NUT, GR5,1/4-20
0190	707625	2	WSHR, 3 WAVE, .750
0200	703902	2	NUT, HEX, 5/16-18

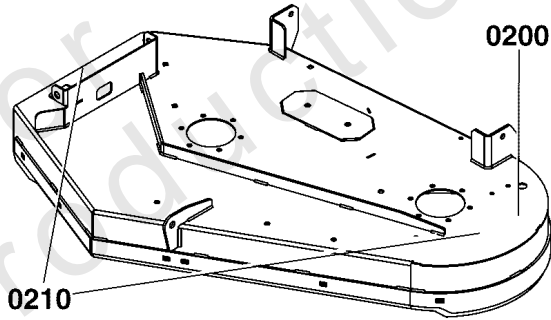
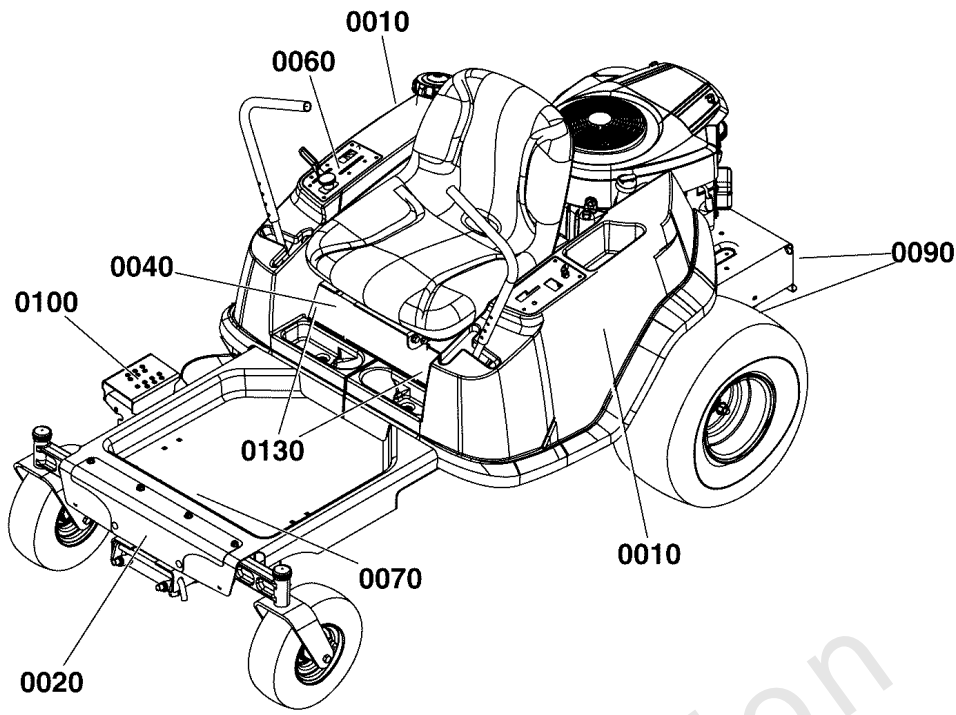

Belts & Blades	
Transmission Drive Belt	
Rear - Fixed Frame	1758100YP
36" Mower	
Deck Drive Belt	84001701
Mower Blade (RH)	84001711
Mower Blade (LH)	84001712
44" Mower	
Deck Drive Belt	84001702
Mower Blade	1716696ASM
46" Mower	
Deck Drive Belt	84001703
Mower Blade	1737228BZYP

0140



0040



0020



0010

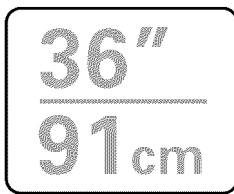

0200



0100



0060

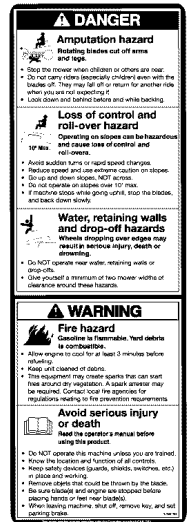

0070



0130

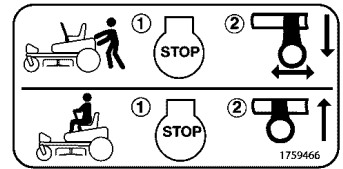

0090



0210

Decals Group (2992662)

REF NO	PART NO	QTY	DESCRIPTION
0010	1760170YP	2	DECAL, Logo, Snapper
0020	1750913YP	1	DECAL, SNAPPER LOGO
0040	1758364YP	1	DECAL, 360Z
0060	7105868YP	1	DECAL, ENGINE SPEED
0070	1758193YP	1	DECAL
0090	1758366YP	2	DECAL, Tow Release
0090	1759466YP	2	DECAL
0100	84002224	1	DECAL, Height of Cut
0130	1759724YP	2	DECAL, Tracking Adjustment - ZT
0140	84002225	1	DECAL, Service Parts
0200	84002226	1	DECAL, 36"/91cm
0210	7101665YP	2	DECAL, DANGER

Not For Reproduction

Electrical Group (80079600)

Note: Unless noted otherwise, use the standard torque specifications

Mfg. No: 2691499-00

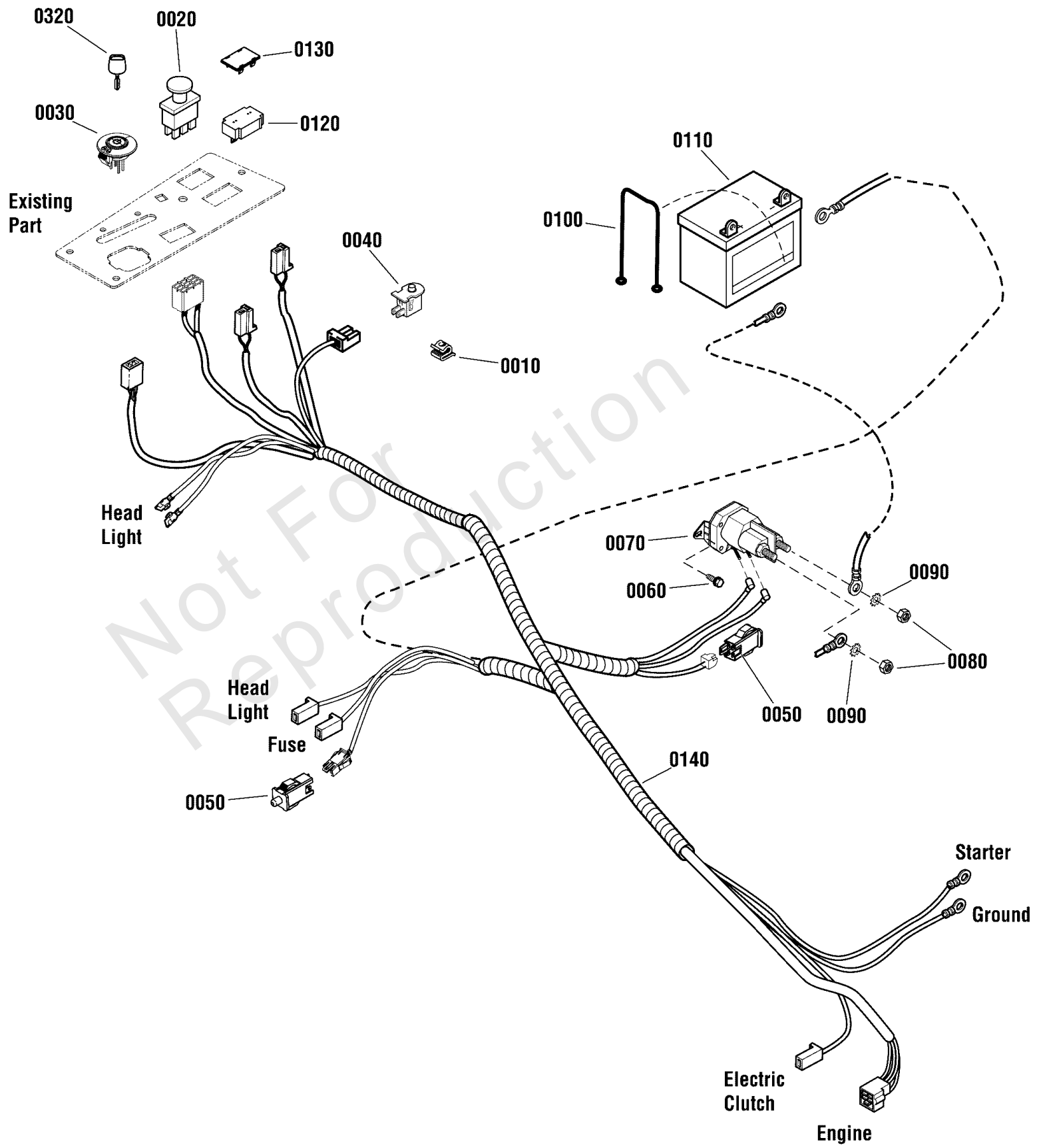

Electrical Group (80079600)

REF NO	PART NO	QTY	DESCRIPTION
0010	2172434SM	1	CLIP- WIRE DIA .390
0020	1722887SM	1	SWITCH-PTO PUSH
0030	7106169YP	1	SWITCH, IGNITION, DEL
0040	7023354YP	1	SWITCH, SEAT
0050	7022886YP	2	SWITCH, DP NO/NC SNAP
0060	1960252SM	2	BOLT-RD HD SH SQ NK 1
0070	1755382YP	1	SOLENOID
0080	703463	2	NUT, GR5,1/4-20
0090	703061	3	NUT, HEX KEPS, 1/4-20
0100	1722009SM	1	STRAP, Rubber, 13"
0110	-----	1	BATTERY, 12 Volt, 230 CCA -(Not a serviceable part)
0120	1731185SM	1	METER-HOUR DIGITAL NO
0130	1722611SM	1	PLUG-HOLE BLACK
0140	84002334	1	HARNESS ASSEMBLY
0320	7106172YP	1	KEY, Ignition Switch - Pack of 2, CE/CAN
0320	7106170YP	1	KEY, Ignition Switch, Pack of 2, NA/AU

Engine Group

Note: Unless noted otherwise, use the standard torque specifications

Mfg. No: 2691499-00

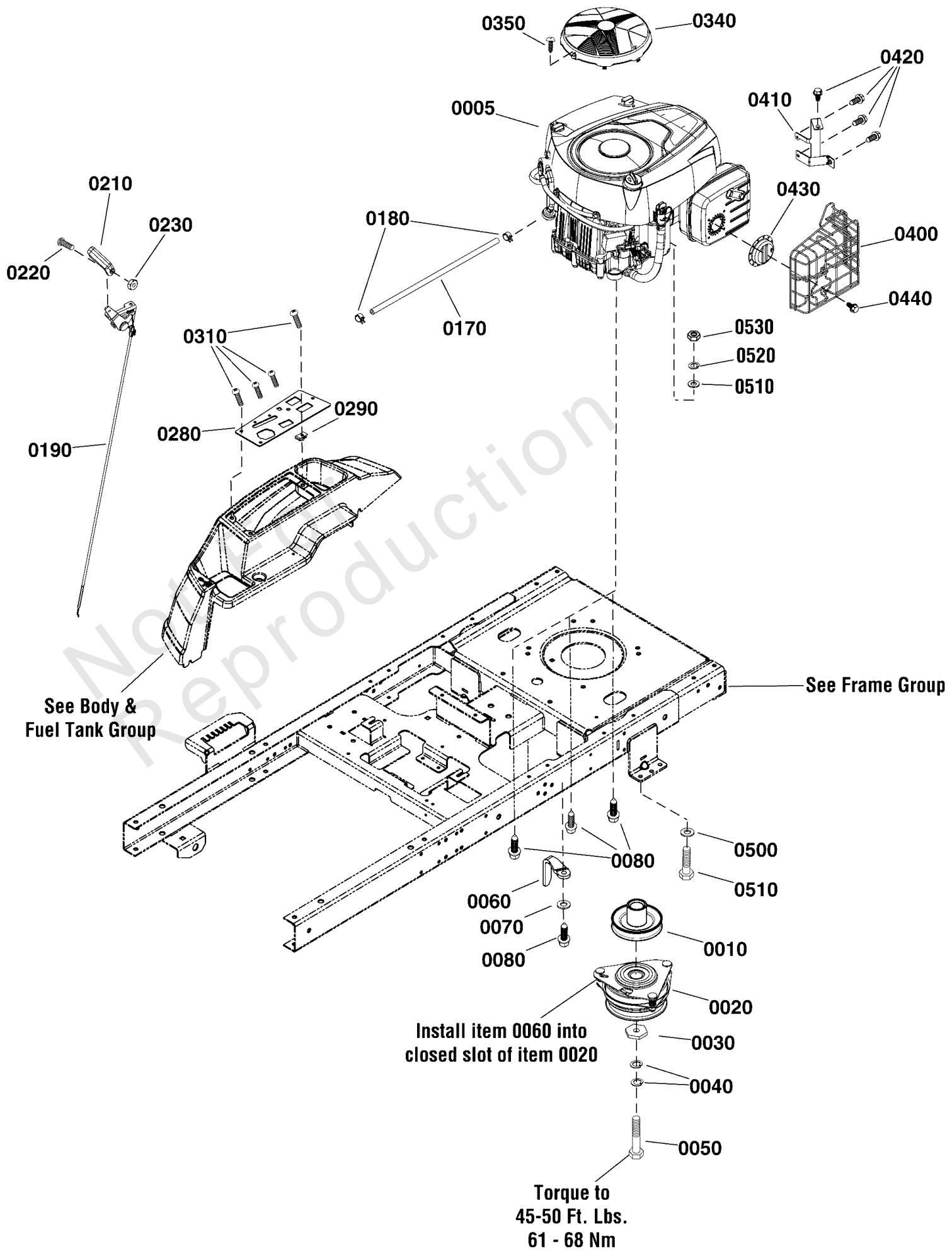

Engine Group

REF NO	PART NO	QTY	DESCRIPTION
0005	33S877-0022-G1	1	*ENGINE, 19 Gross HP B&S Single -(Engine Model: 33S87-0022-G1)
0010	1757995YP	1	ASSEMBLY-PULLEY
0020	1736105SM	1	CLUTCH, ELECTRIC
0030	1708264SM	1	WASHER, HEX, 0.453ID
0040	1960769YP	2	WASHER, Belleville
0050	771023	1	CAPSCREW, Hex Head, Loctite, 7/16-20 x 3 1/2
0060	1737421AYP	1	GUIDE, Belt
0070	703878	1	WASHER, FLAT
0080	2828635SM	4	SCREW-HEX WSHR HD TAP
0170	791766	1	LINE, Fuel
0180	691038	2	CLAMP, Hose
0190	1759205YP	1	CONTROL-THROTTLE
0210	1739312YP	1	KNOB, THROTTLE
0220	797483	1	SCREW
0230	703460	1	NUT, Hex #8-32
0280	84001947	1	PANEL, Control
0290	705876	3	NUT
0310	7090999SM	5	SCREW, Phillips Head, 1/4-20 X 5/8
0340	799358	1	GUARD, Debris Screen
0350	799359	1	SCREW
0400	597456	1	GUARD, MUFFLER
0410	597456	1	GUARD, MUFFLER -(Included with Ref Nos 0400)
0420	703054	4	SCREW, 1/4-20X0.625
0430	795038	1	DEFLECTOR, Muffler
0440	96046	1	SCREW, Hex Washer Head
0500	7091513YP	1	SCREW, 5/16-24X1-3/4
0510	703350	2	WASHER
0520	703116	1	LCKWSHR
0530	703331	1	NUT, 5/16-24

Footnotes:

Note:* See your local Briggs & Stratton distributor for parts & service.

Evap Group

Note: Unless noted otherwise, use the standard torque specifications

Mfg. No: 2691499-00

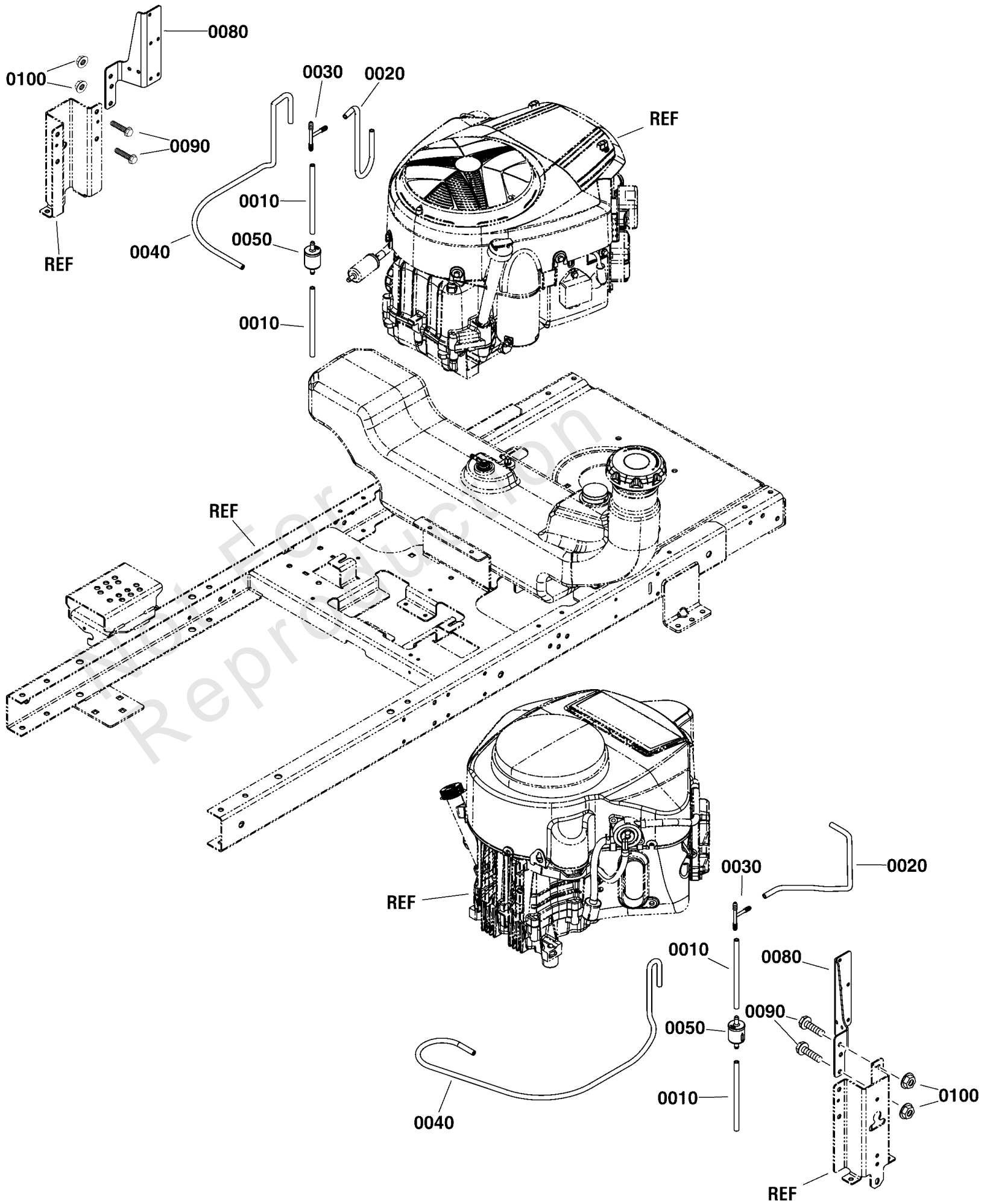

Evap Group

REF NO	PART NO	QTY	DESCRIPTION
0010	7700552X6YP	2	HOSE-VAPOR
0020	7700552X12YP	1	HOSE, VAPOR,5MM ID,12
0030	5103062YP	1	FITTING, 3/16" TEE, B
0040	7700552X26YP	1	HOSE, Vapor, 5 MM ID, 26.00 LG -(Cut to length)
0050	84001895	1	FILTER, Fuel
0080	1760538AYP	1	BRACKET
0090	703410	2	BOLT,5/16-18X1
0100	703115	2	NUT

Not For Reproduction

Frame Group (2992584)

Note: Unless noted otherwise, use the standard torque specifications

Mfg. No: 2691499-00

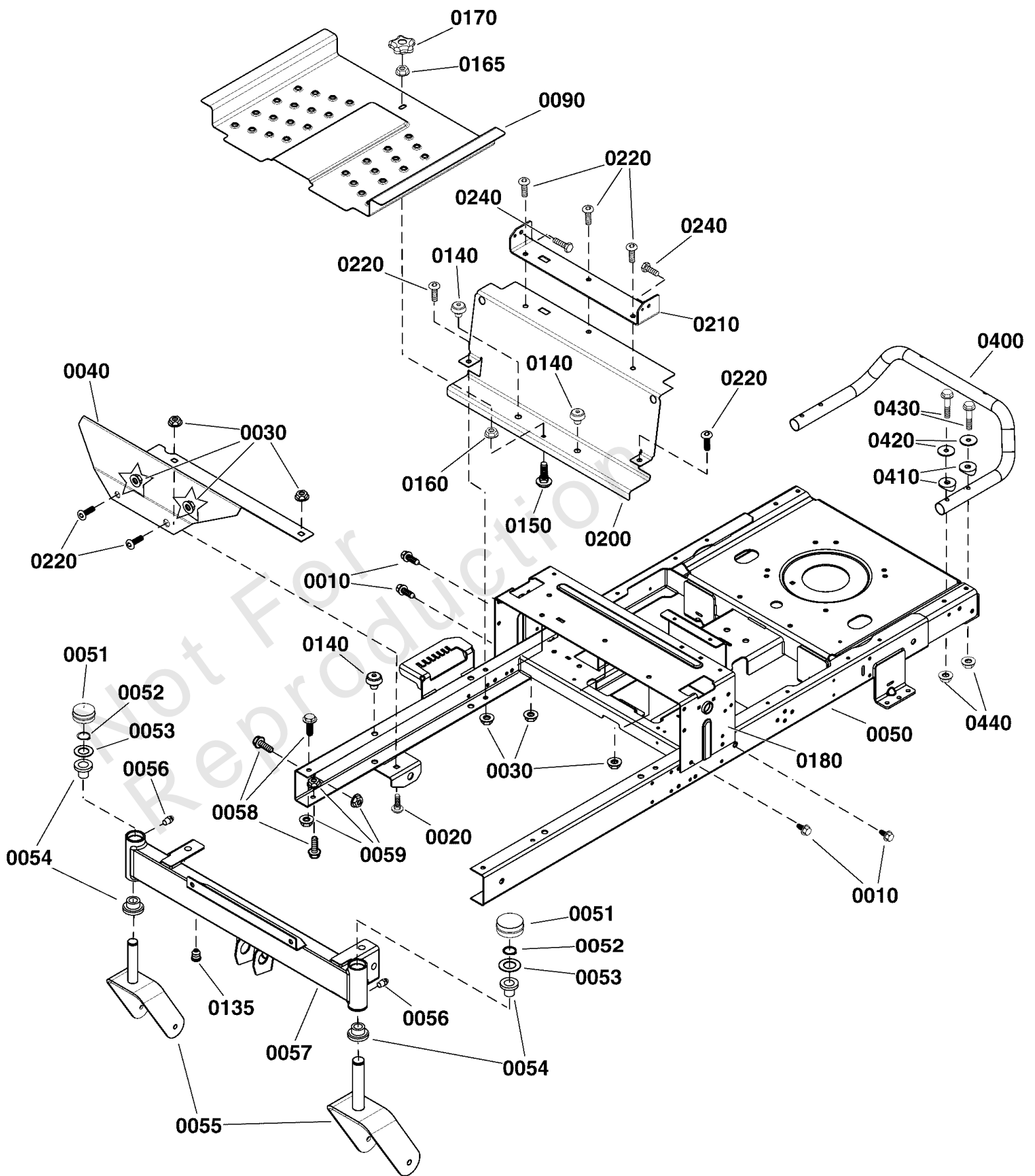

Frame Group (2992584)

REF NO	PART NO	QTY	DESCRIPTION
0010	703949	4	SCREW, 5/16-18.625
0020	703448	2	BOLT, 3/8-16X.75 G5
0030	703158	9	NUT, Hex Flange, 3/8-16
0040	84002333	1	FOOTREST, Front
0050	-----	1	FRAME -(Not a serviceable part)
0051	84002102	2	CAP, Vinyl
0052	703993	2	RETAINER, EXT RING, 1
0053	703149	2	WSHR
0054	1721682SM	4	BUSHING, 31/32 x 1-1/4 x 3/4, Powder Metal
0055	84002868	2	CASTER, Yoke
0056	1704314SM	2	LUBE FITTING, .250 DR
0057	84002869	1	FRONT AXLE ASSEMBLY
0058	704038	6	SCREW
0059	703893	6	NUT, CNTR LCK, 3/8-16
0090	1757813DYP	1	PAN, Foot
0135	7046780SM	1	PLUG, Hole, .44" OD
0140	197546GS	6	MOUNT-VIBRATION
0150	7090496YP	1	RHSSNB, 1/4C X1 GR5 Z
0160	703233	1	NUT, 1/4-20, GR5
0165	15X143MA	1	NUT,25-20 HEX FLG CTR
0170	707785	1	KNOB
0180	1758010DYP	1	BRACKET, Control
0200	1757796DYP	1	BRACKET, Brand
0210	84001615	1	BRACKET, Seat
0220	707790	7	SCREW, Button Head, 3/8-16 X .88
0240	703932	2	SCREW, 5/16-18X.5
0400	84002103	1	BUMPER, Tube
0410	1759361YP	4	SADDLE, Tube, 1.25 O.D.
0420	1960044SM	4	WASHER-0.312(0.33IDX1
0430	707944	4	SCREW, Washer Head, 5/16-18 X 2 1/4
0440	703115	4	NUT

Lift Group

Note: Unless noted otherwise, use the standard torque specifications

Mfg. No: 2691499-00

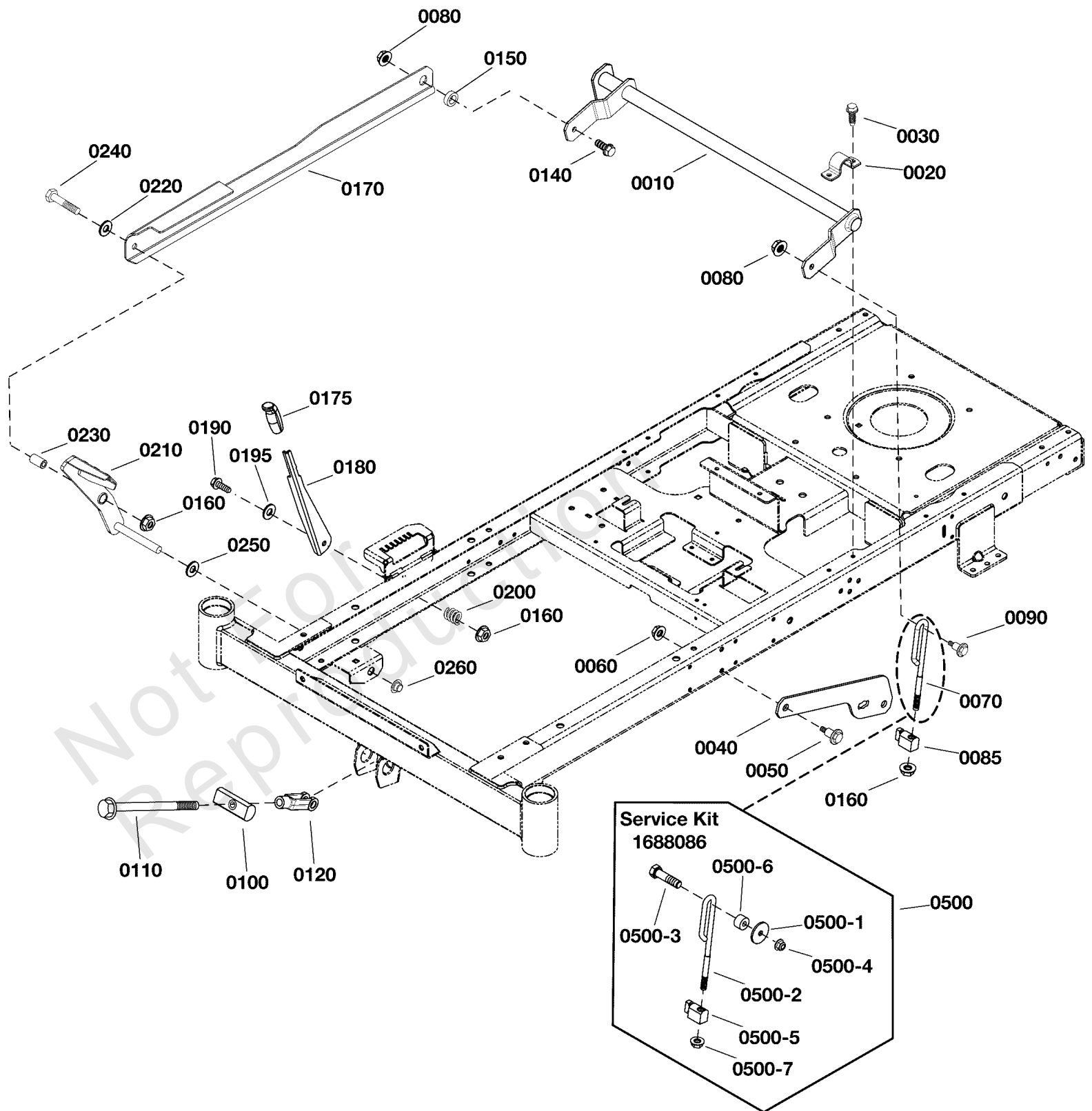

Lift Group

REF NO	PART NO	QTY	DESCRIPTION
0010	84001704	1	SHAFT, Lift
0020	1761690HYP	2	STRAP, ROCKER SHAFT
0030	703949	4	SCREW, 5/16-18.625
0040	1757953AYP	2	ARM, Lift
0050	1732426SM	2	BOLT-SHLDR 5/16-18 0.
0060	703115	2	NUT
0070	1757936YP	2	ROD, Lift
0080	703158	2	NUT, Hex Flange, 3/8-16
0085	1731894SM	2	TRUNNION
0090	009X51MA	2	BOLT-SHD.38-16X.499D
0100	1757955YP	1	PIVOT
0110	1757954YP	1	ROD
0120	5023174SM	1	CLEVIS, 1/2-20, STEEL
0140	704038	1	SCREW
0150	1663752SM	1	SPACER, 25/64 x 5/8 x 3/16
0160	703893	3	NUT, CNTR LCK, 3/8-16
0170	84001705	1	LINK, Lift
0175	84001706	1	GRIP
0180	84001707	1	LEVER, Height Adjust
0190	770137	1	BOLT
0195	704128	1	WASHER
0200	2162085SM	1	SPRING, Compression
0210	84001708	1	PEDAL
0220	703878	1	WASHER, FLAT
0230	1756612YP	1	BUSHING, DIFF. LOCK
0240	703589	1	CAPSCREW, 3/8-16X2
0250	703580	1	WASHER, 5/8
0260	771009	1	PUSHNUT, 5/8
0500	1688086	1	KIT, ROD, LIFT LEVER
0500-1	5025305SM	2	WASHER, .41 X 1.75 X
0500-2	84003818	2	ROD, Lift
0500-3	703406	2	CAPSCREW,3/8-16X1.5
0500-4	703158	2	NUT, Hex Flange, 3/8-16
0500-5	84003820	2	TRUNNION
0500-6	5100334SM	2	SPACER
0500-7	5025396SM	2	NUT, Hex Flange, 1/2-13

Parking Brake Group (2991641)

Note: Unless noted otherwise, use the standard torque specifications

Mfg. No: 2691499-00

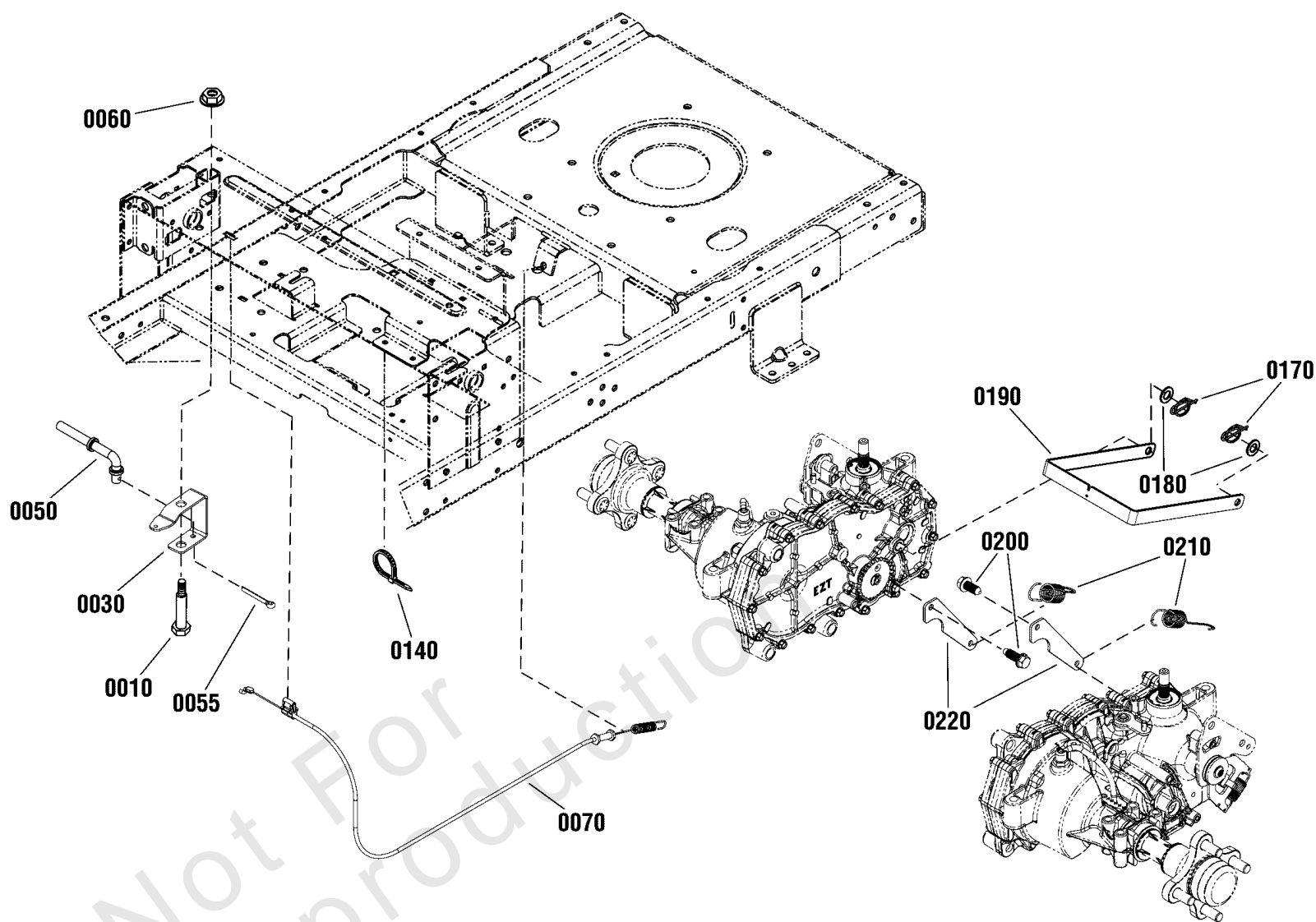

Parking Brake Group (2991641)

REF NO	PART NO	QTY	DESCRIPTION
0010	1736539YP	1	BOLT, SHOULDER
0030	1758091YP	1	BELLCRANK, Parking Brake
0050	1758088YP	1	ROD, Parking Brake
0055	703312	1	PIN, COTTER, 3/32X.75
0060	703158	1	NUT, Hex Flange, 3/8-16
0070	1759207YP	1	CABLE, PARKING BRAKE
0140	703586	1	TIE, SELF LOCKING
0170	7091594SM	2	COTTER PIN, 1/2 SELF,
0180	703946	2	WASHER, .39IDX.72OD
0190	1758126AYP	1	ARM, Parking Brake
0200	708964	2	SCREW
0210	1758283YP	2	SPRING, EXTENSION
0220	1759349YP	2	BRACKET, Spring

Not For Reproduction

Seat Group

Note: Unless noted otherwise, use the standard torque specifications

Mfg. No: 2691499-00

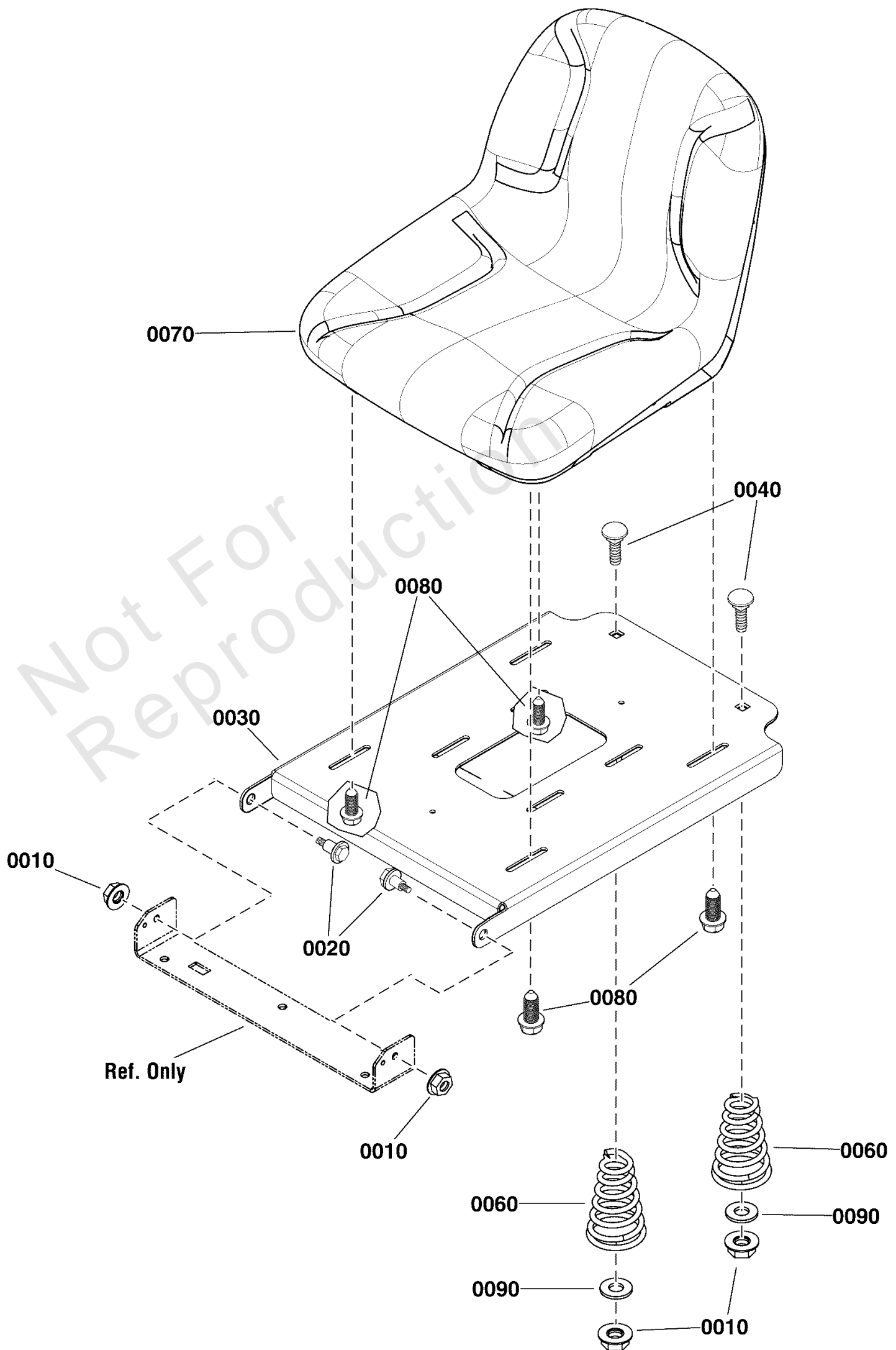

Seat Group

REF NO	PART NO	QTY	DESCRIPTION
0010	703115	4	NUT
0020	1752802YP	2	BOLT, SHLDR, 5/16-18
0030	84001618	1	SLIDE, SEAT
0040	703483	2	BOLT,5/16-18X1.000,RO
0060	1717051SM	2	SPRING, Seat
0070	84003332	1	SEAT ASSEMBLY, w/out Armrests
0080	1960667SM	4	SCREW-HEX WZ LOCK FLN
0090	703591	4	WASHER, .406X1.5X.12

Not For Reproduction

Transmission Group

Note: Unless noted otherwise, use the standard torque specifications

Mfg. No: 2691499-00

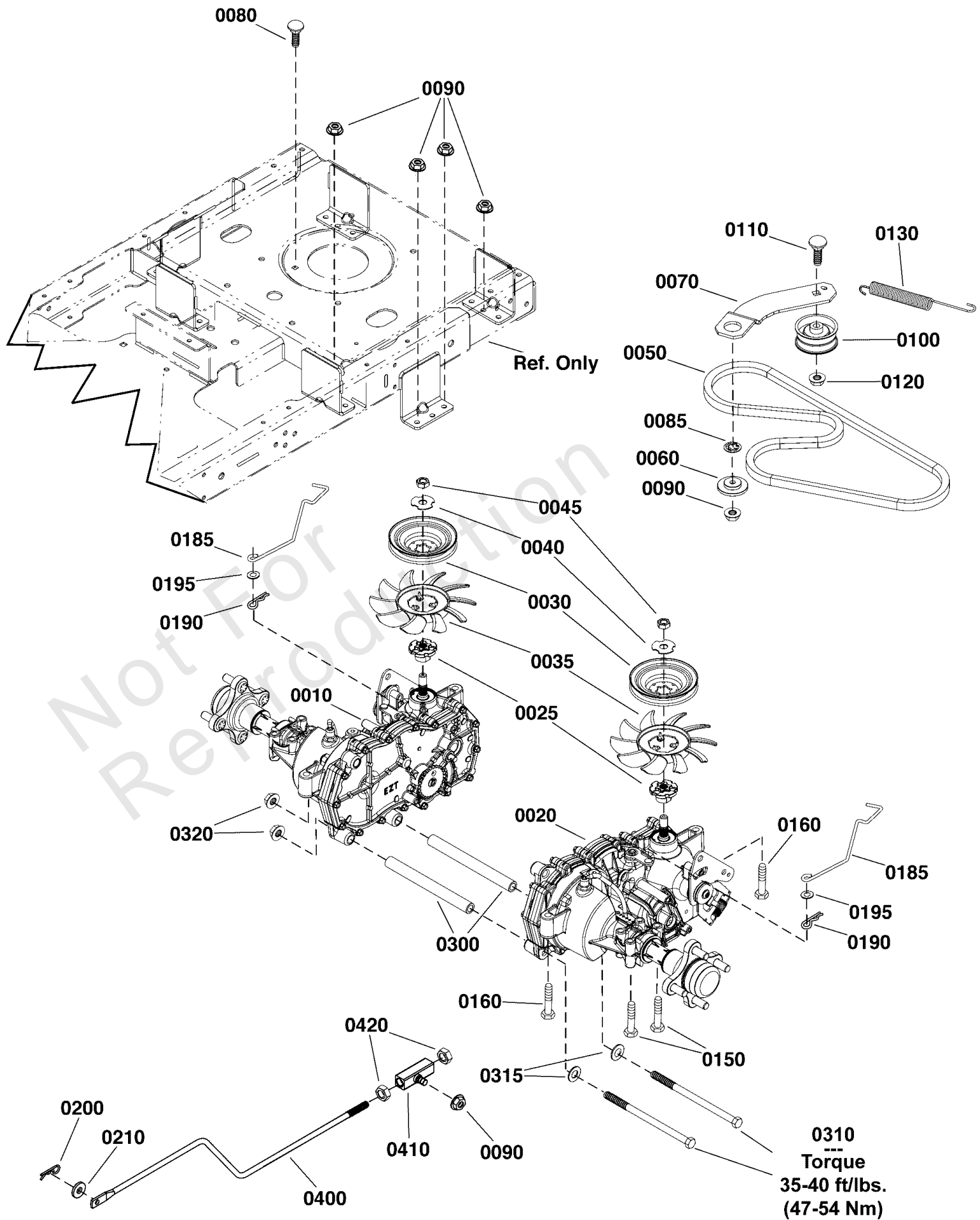

Transmission Group

REF NO	PART NO	QTY	DESCRIPTION
0010	84002176	1	* TRANSMISSION, EZT, RH -(Refer to Note: *) (Model: (ZD-DPBB-2A7C-2XPX)
0020	84002177	1	* TRANSMISSION, EZT, LH -(Refer to Note: *) (Model: (ZD-APBB-2A7B-3XPX)
0025	1759450YP	2	SPACER
0030	1759447YP	2	PULLEY, Transmission
0035	1759448YP	2	FAN, Input
0040	5102914YP	2	WASHER, ZT5400, SLOTT
0045	5102916YP	2	NUT, ZT5400
0050	1758100YP	1	BELT-TRANSMISSION
0060	1727935SM	1	SPACER-PIVOT 0.330ID
0070	1758044AYP	1	ARM, Idler
0080	703800	1	BOLT, CRRG, 5/16-18X1
0085	703297	1	RETAINER, GR5, 5/16
0090	703115	11	NUT
0100	1668477SM	1	PULLEY, Idler, 2.25" OD, .378 ID
0110	703879	1	BOLT, SQ, 3/8-16X1.75
0120	703158	1	NUT, Hex Flange, 3/8-16
0130	1758045YP	1	SPRING-EXTENSION
0150	707943	4	SCREW
0160	707944	4	SCREW, Washer Head, 5/16-18 X 2 1/4
0185	84002179	2	ROD, Roll Release
0190	703430	2	PIN, 13X1.19
0195	703332	2	WASHER
0200	703300	2	PIN, 3/32 X 1.6
0210	704138	2	TANK-FUEL
0300	1759392YP	2	SPACER, Transmission
0310	707945	2	CAPSCREW, HexHead, 7/16-14 X 11 1/4
0315	703183	2	WASHER, 7/16 ID X.065
0320	1930650SM	2	NUT-HEX FLANGE 7/16-1
0400	84002180	2	CONTROL ROD, Transmission
0410	84002181	2	TRUNNION
0420	7090460	4	NUT, 7/16-20 Hex, GR 5 or B

Footnotes:

Note *See your local Hydro Gear dealer for parts and service.

Wheel & Tire Group

Note: Unless noted otherwise, use the standard torque specifications

Mfg. No: 2691499-00

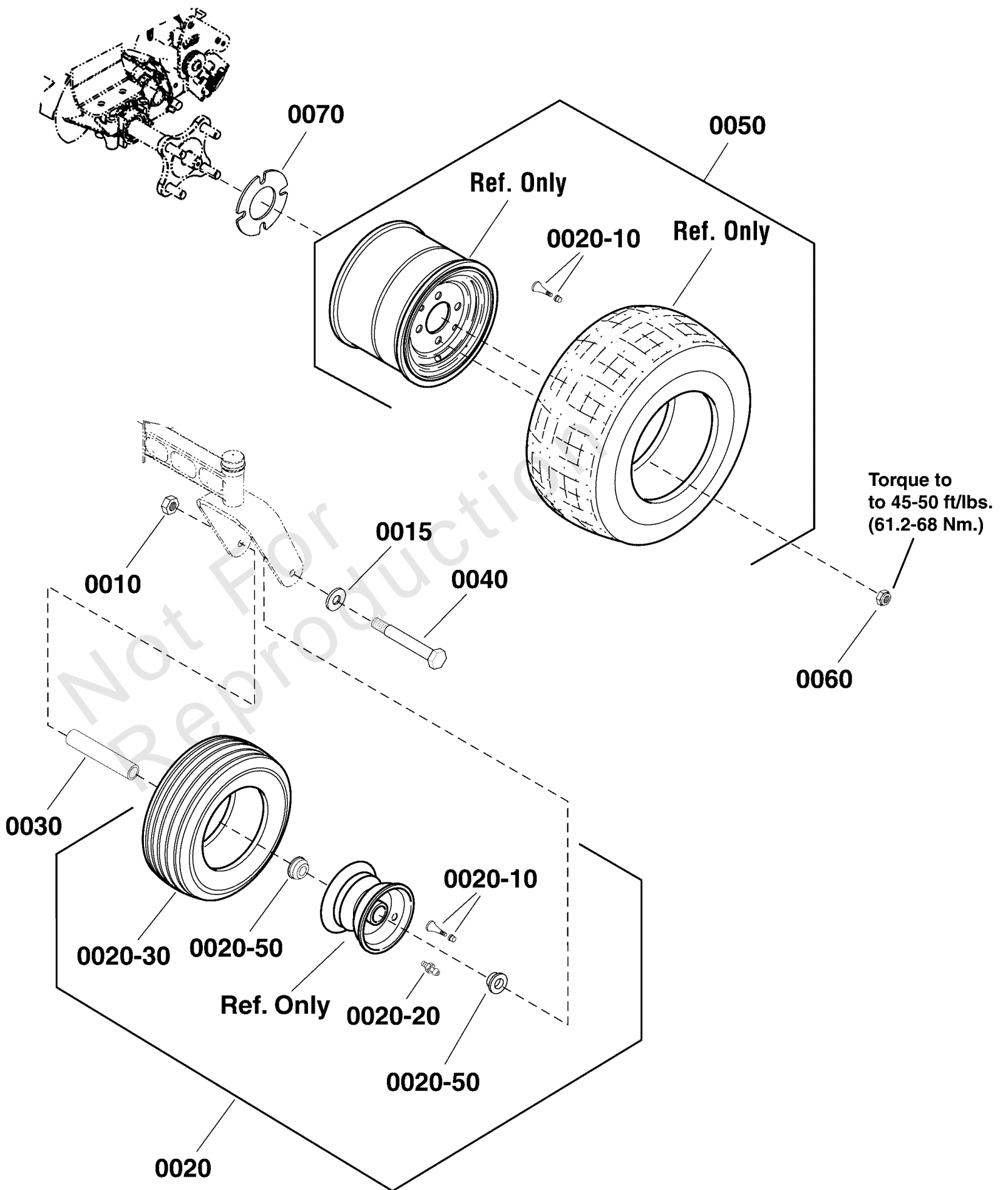

Wheel & Tire Group

REF NO	PART NO	QTY	DESCRIPTION
0010	1930650SM	2	NUT-HEX FLANGE 7/16-1
0015	703183	2	WASHER, 7/16 ID X.065
0020	1734013SM	2	WHEEL & TIRE ASSY
0020-10	2172353SM	4	VALVE STEM & CAP
0020-20	7104428YP	2	ZERK, Grease
0020-30	1734875SM	2	TIRE, 11 X 4-5
0020-50	1739281YP	4	BUSHING, 0.632ID, 1.377OD, 0.62 LG
0030	1734841SM	2	SPACER - CASTER
0040	7091772SM	2	HHCS, 7/16C X6 GR5 YZ
0050	84001649	2	REAR WHEEL ASSEMBLY
0060	5020601SM	8	NUT, 1/2-20, FOR WHEEL BOLT SILVER
0070	84002077	2	PLATE, Wheel

Not For Reproduction

Hardware Identification & Torque Specifications

Torque Specification Chart								
FOR STANDARD METRIC MACHINE HARDWARE (Tolerance ± 20%)								
Property Class	5.6		8.8		10.9		12.9	
	Class 5.6		Class 8.8		Class 10.9		Class 12.9	
Size Of Hardware	in/lbs	Nm.	in/lbs	Nm.	in/lbs	Nm.	in/lbs	Nm.
	ft/lbs		ft/lbs		ft/lbs		ft/lbs	
M3	5.88	.56	13.44	1.28	19.2	1.80	22.92	2.15
M4	13.44	1.28	30.72	2.90	43.44	4.10	52.56	4.95
M5	26.4	2.50	60.96	5.75	5.97	8.10	7.15	9.7
M6	44.64	4.3	7.3	9.9	10.3	14	12.1	16.5
M7	5.2	7.1	12.1	16.5	16.9	23	19.9	27
M8	7.7	10.5	17.7	24	25	34	29	40
M10	15	21	35	48	50	67	59	81
M12	26	36	61	83	86.2	117	103	140
M14	42	58	101	132	136	185	162	220
M16	64	88	147	200	210	285	250	340
M18	89	121	202	275	287	390	346	470
M20	126	171	290	390	405	550	486	660
M22	169	230	390	530	559	745	656	890
M24	217	295	497	375	708	960	840	1140
M27	320	435	733	995	1032	1400	1239	1680
M30	435	590	995	1350	1401	1900	1681	2280
M33	590	800	1349	1830	1902	2580	2278	3090
M36	759	1030	1740	2360	2441	3310	2935	3980
M39	988	1340	2249	3050	3163	4290	3798	5150

Torque Specification Chart						
FOR STANDARD MACHINE HARDWARE (Tolerance ± 20%)						
Hardware Grade	No Marks		SAE Grade 5		SAE Grade 8	
	SAE Grade 2		SAE Grade 5		SAE Grade 8	
Size Of Hardware	in/lbs	Nm.	in/lbs	Nm.	in/lbs	Nm.
	ft/lbs		ft/lbs		ft/lbs	
8-32	19	2.1	30	3.4	41	4.6
8-36	20	2.3	31	3.5	43	4.9
10-24	27	3.1	43	4.9	60	6.8
10-32	31	3.5	49	5.5	68	7.7
1/4-20	66	7.6	8	10.9	12	16.3
1/4-28	76	8.6	10	13.6	14	19.0
5/16-18	11	15.0	17	23.1	25	34.0
5/16-24	12	16.3	19	25.8	29	34.0
3/8-16	20	27.2	30	40.8	45	61.2
3/8-24	23	31.3	35	47.6	50	68.0
7/16-14	30	40.8	50	68.0	70	95.2
7/16-20	35	47.6	55	74.8	80	108.8
1/2-13	50	68.0	75	102.0	110	149.6
1/2-20	55	74.8	90	122.4	120	163.2
9/16-12	65	88.4	110	149.6	150	204.0
9/16-18	75	102.0	120	163.2	170	231.2
5/8-11	90	122.4	150	204.0	220	299.2
5/8-18	100	136	180	244.8	240	326.4
3/4-10	160	217.6	260	353.6	386	525.0
3/4-16	180	244.8	300	408.0	420	571.2
7/8-9	140	190.4	400	544.0	600	816.0
7/8-14	155	210.8	440	598.4	660	897.6
1-8	220	299.2	580	788.8	900	1,244.0
1-12	240	326.4	640	870.4	1,000	1,360.0

The guides and ruler furnished below are designed to help you select the appropriate hardware.



Nut, M8

Thread Diameter (mm)

Inside Diameter (in) Threads per inch

Nut, 1/2-16



Screw, M8- 1.25 x 25

Thread Diameter (mm) Distance between threads (mm) Body Length (mm)

Body Diameter Threads per inch Body Length (in)

Screw, 1/2- 16 x 2



Standard Hardware Sizing

When a washer or nut is identified as 1/2" (M8), this is the *Nominal size*, meaning the *inside diameter* is 1/2 inch (8mm metric thread diameter); if a second number is present it represents the *threads per inch* (distance between threads).

When bolt or capscrew is identified as 1/2 - 16 x 2" (M8 - 1.25 x 50), this means the *Nominal size*, or body diameter is 1/2 inch (8mm metric thread diameter), the second number, 16, represents the *threads per inch*, (*distance between threads*). The final number is the body length of the bolt or screw, 2 inches (50mm).

NOTES

- These torque values are to be used for all hardware excluding: locknuts, self-tapping screws, thread forming screws, sheet metal screws and socket head setscrews.
- Recommended seating torque values for locknuts:
 - for prevailing torque locknuts - use 65% of grade 5 torques.
 - for flange whizlock nuts and screws - use 135% of grade 5 torques.
- Unless otherwise noted on assembly drawings, all torque values must meet this specification.

Common Hardware Types

Hex Head Capscrew

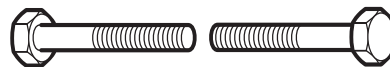

Washer



Carriage Bolt



Hex Nut

Wrench & Fastener Size Guide

1/4" Bolt or Nut Wrench—7/16"	5/16" Bolt or Nut Wrench—1/2"	3/8" Bolt or Nut Wrench—9/16"	7/16" Bolt or Nut Wrench (Bolt)—5/8" Wrench (Nut)—11/16"	1/2" Bolt or Nut Wrench—3/4"
M6 Bolt or Nut Wrench—10mm	M8 Bolt or Nut Wrench—13mm	M10 Bolt or Nut Wrench—17mm	M12 Bolt or Nut Wrench—19mm	M14 Bolt or Nut Wrench—22mm

