



Parts Manual

Mfg. No: 1687921-00
ESXD21SPWM82K, 82V Battery Electric
21" SP Walk Mower Kit



Model Components	Page
Battery & Cover Group.....	4
Handles Group.....	10
Wheels & Deck Group.....	14
Torque Specification Chart.....	16

Not For
Reproduction

Battery & Cover Group

Note: Unless noted otherwise, use the standard torque specifications

Mfg. No: 1687921-00

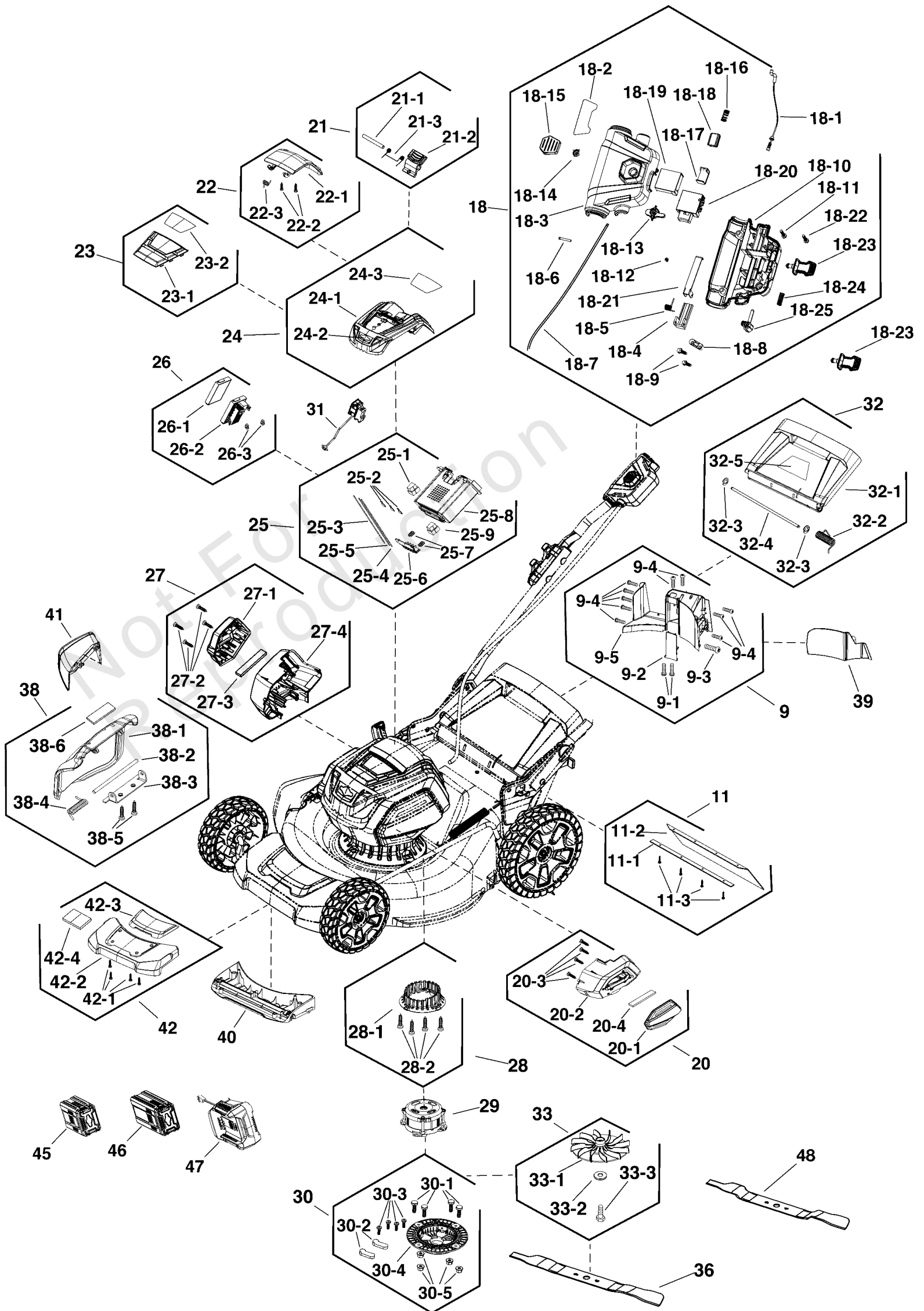

Battery & Cover Group

REF NO	PART NO	QTY	DESCRIPTION
9	771587	1	KIT, Rear Baffle
9-1	-----	2	SCREW, Pan Torx Self Tap, ST4.2 x 20-C
9-2	-----	1	COVER
9-3	-----	1	SCREW
9-4	-----	10	SCREW
9-5	-----	1	BULKHEAD, Back
11	771589	1	KIT, Rear Flap
11-1	-----	1	BRACE
11-2	-----	1	FLAP, Rear
11-3	-----	4	SCREW ST4.2-16
18	771611	1	KIT, Start Button
18-1	84003402	1	CABLE, Bail
18-2	-----	1	DECAL
18-3	-----	1	COVER, Upper
18-4	-----	1	SLIDER
18-5	-----	1	SPRING
18-6	-----	1	PIN
18-7	-----	1	WIRE
18-8	-----	1	CLAMP
18-9	-----	2	SCREW ST4.2-16
18-10	-----	1	COVER, Bottom
18-11	-----	2	SCREW, Pan Torx Self Tap, ST4.2 x 20-C
18-12	-----	1	SCREW
18-13	-----	1	COVER, Bottom
18-14	-----	1	SPRING
18-15	84003403	1	BUTTON, Start
18-16	-----	1	SPRING
18-17	-----	1	SLIDER
18-18	-----	1	COVER, Bottom
18-19	-----	1	INSERT
18-20	84003405	1	SWITCH
18-21	-----	1	PLATE
18-22	-----	2	SCREW ST4.2*25
18-23	84002646		KEY, Safety
18-24	-----	1	SPRING
18-25	-----	1	LOCK
20	770198	1	KIT, Cover, Left
20-1	-----	1	HOUSING, Left
20-2	-----	1	COVER, Left
20-3	-----	4	SCREW
20-4	-----	1	SCREEN, Dust
21	770202	1	KIT, Battery Release
21-1	-----	1	PIN
21-2	-----	1	BUTTON
21-3	-----	1	SPRING
22	770195	1	KIT, Battery Cover
22-1	-----	1	COVER, Battery
22-2	-----	2	SCREW
22-3	-----	1	SPRING
23	771599	1	KIT, Cover
23-1	-----	1	COVER

Battery & Cover Group

Note: Unless noted otherwise, use the standard torque specifications

Mfg. No: 1687921-00

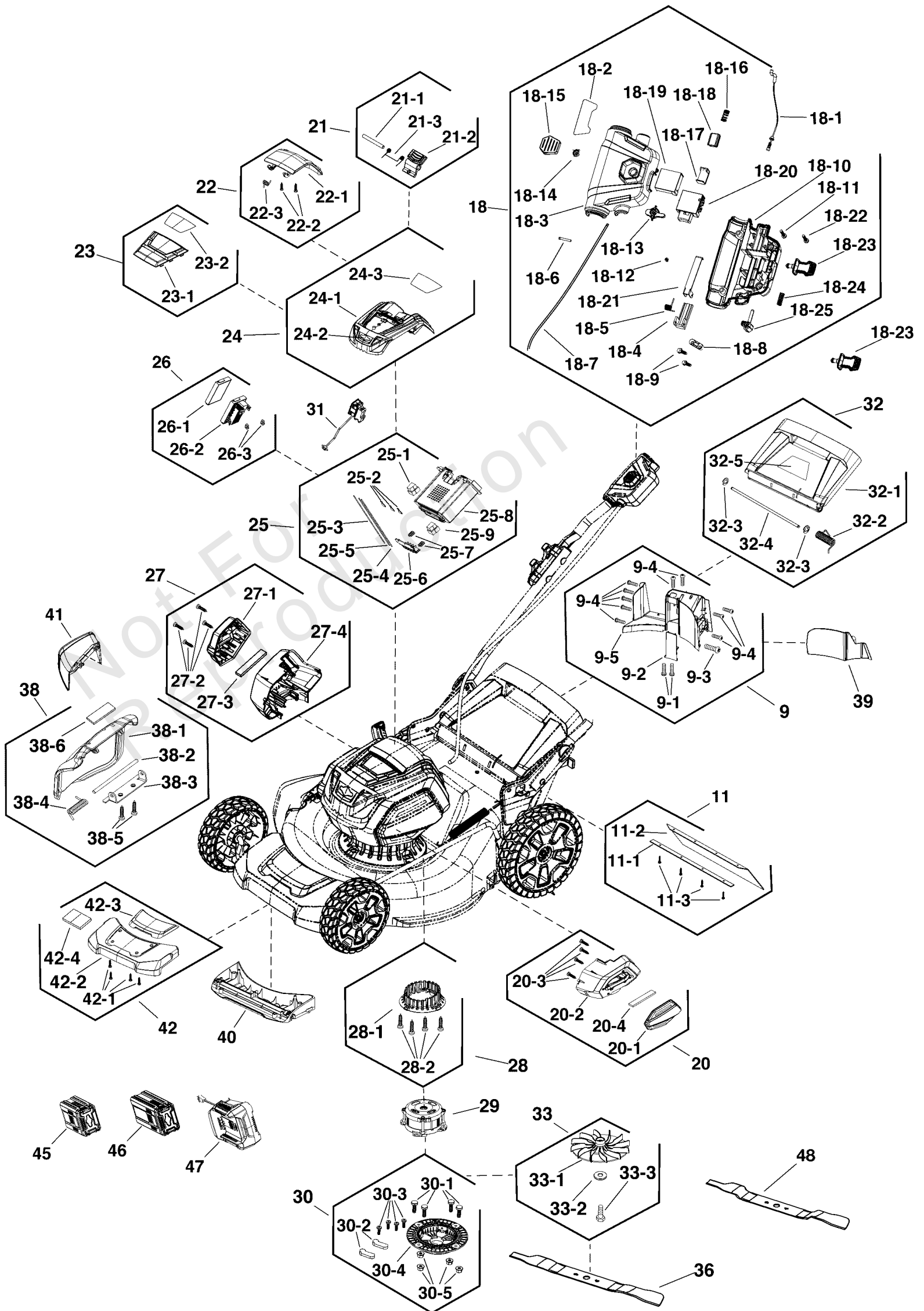

Battery & Cover Group

REF NO	PART NO	QTY	DESCRIPTION
23-2	-----	1	SHROUD
24	770201	1	KIT, Top Cover
24-1	-----	1	COVER, Top
24-2	-----	1	B&S LOGO
24-3	-----	1	LABEL
25	771601	1	KIT, Battery Box
25-1	-----	1	CONNECTOR
25-2	-----	3	CONTACT
25-3	-----	1	WIRE, Yellow
25-4	-----	1	WIRE, Red
25-5	-----	1	WIRE, Black
25-6	-----	1	TERMINAL
25-7	-----	2	SPRING
25-8	-----	1	HOUSING, Battery
25-9	84003412	1	MAGNET
26	771616	1	KIT, PCB
26-1	84003411	1	COVER, PCB
26-2	-----	1	PCB
26-3	84003412	2	MAGNET
27	770197	1	KIT, Cover, Right
27-1	-----	1	COVER, Right
27-2	-----	4	SCREW
27-3	-----	1	SCREEN, Dust
27-4	-----	1	COVER, Right
28	770200	1	KIT, Base
28-1	-----	1	BASE
28-2	-----	4	SCREW, HexHead Self Tap, ST4.2 x 20-C
29	770174	1	KIT, Motor
30	771604	1	KIT, Base, Motor
30-1	-----	4	BOLT
30-2	-----	2	DISC, Tension
30-3	-----	4	SCREW, HexHead Self Tap, ST4.2 x 20-C
30-4	-----	1	BASE
30-5	-----	4	NUT
31	771605	1	KIT, Inverted Switch
32	770181	1	KIT, Rear Cover
32-1	-----	1	LABEL
32-2	-----	1	SPRING
32-3	-----	2	WASHER, Split
32-4	-----	1	SHAFT
32-5	-----	1	COVER, Rear
33	771606	1	KIT, Fan
33-1	-----	1	FAN
33-2	-----	1	WASHER
33-3	-----	1	BOLT, M10 X 35
36	770191	1	KIT, Blade
38	770193	1	KIT, Cover
38-1	-----	1	COVER
38-2	-----	1	PIN
38-3	-----	1	BRACKET
38-4	-----	1	SPRING, Torsion

Battery & Cover Group

Note: Unless noted otherwise, use the standard torque specifications

Mfg. No: 1687921-00

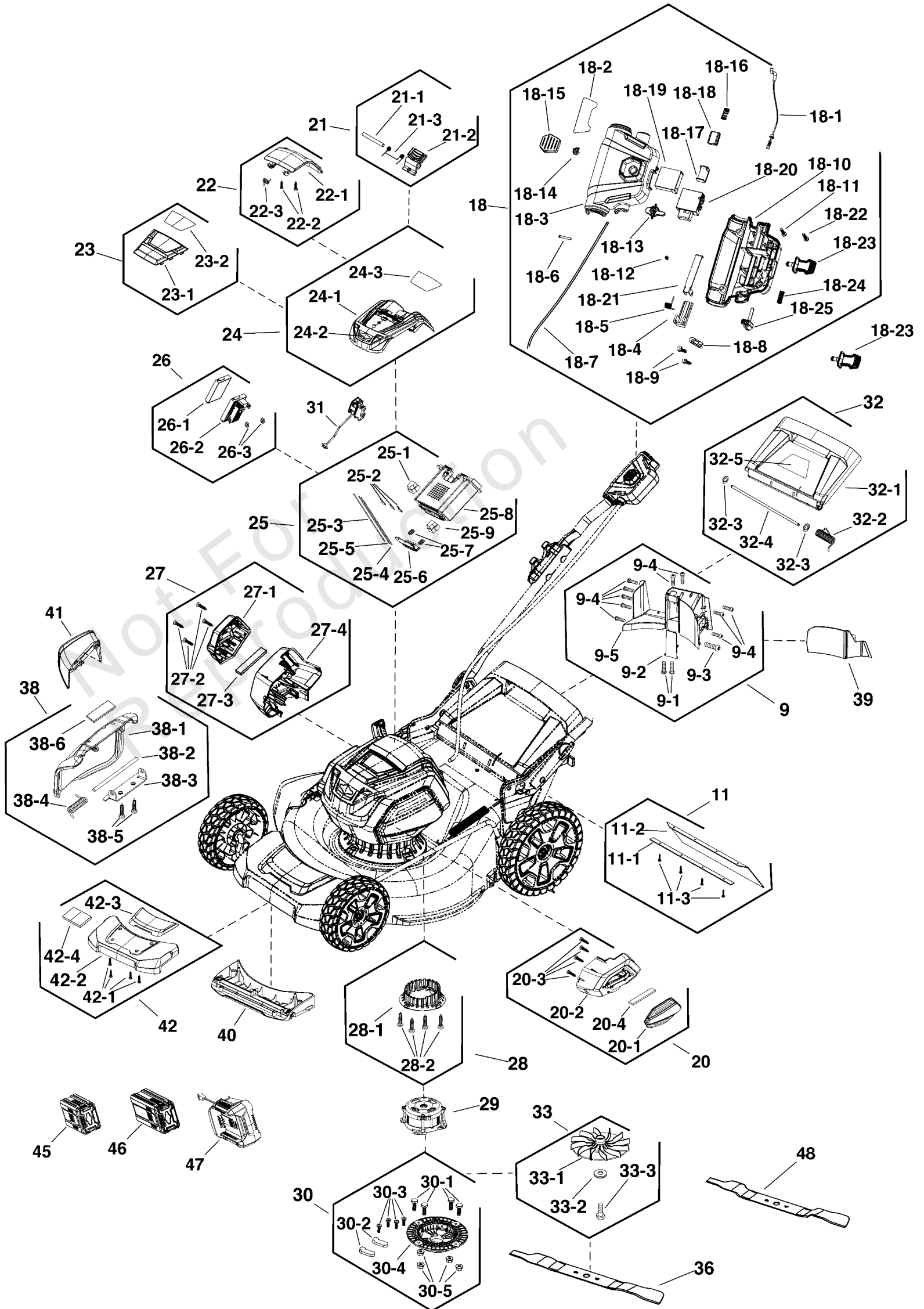

Battery & Cover Group

REF NO	PART NO	QTY	DESCRIPTION
38-5	-----	2	BOLT, Hex Flange, M6 X 12
38-6	-----	1	DECAL, Side Discharge
39	770183	1	KIT, Mulch Plug
40	770206	1	KIT, Front Bulkhead
41	770194	1	KIT, Deflector, Side Discharge
42	770477	1	KIT, Front Panel
42-1	-----	4	SCREW
42-2	-----	1	PANEL
42-3	-----	1	COVER, Panel
42-4	-----	1	DECAL
45	1760514	1	* BATTERY, 2.0, 82V EU/AU -(Optional)
46	1760515	1	* BATTERY, 4.0, 82V EU/AU -(Optional)
47	1760264	1	* CHARGER, Battery, EU -(Optional)
48	84004556	1	BLADE, Mulching, 21" -(Optional)
--	770294	1	REMOTE BELT FOR BATTERY -(Not Shown)

Handles Group

Note: Unless noted otherwise, use the standard torque specifications

Mfg. No: 1687921-00

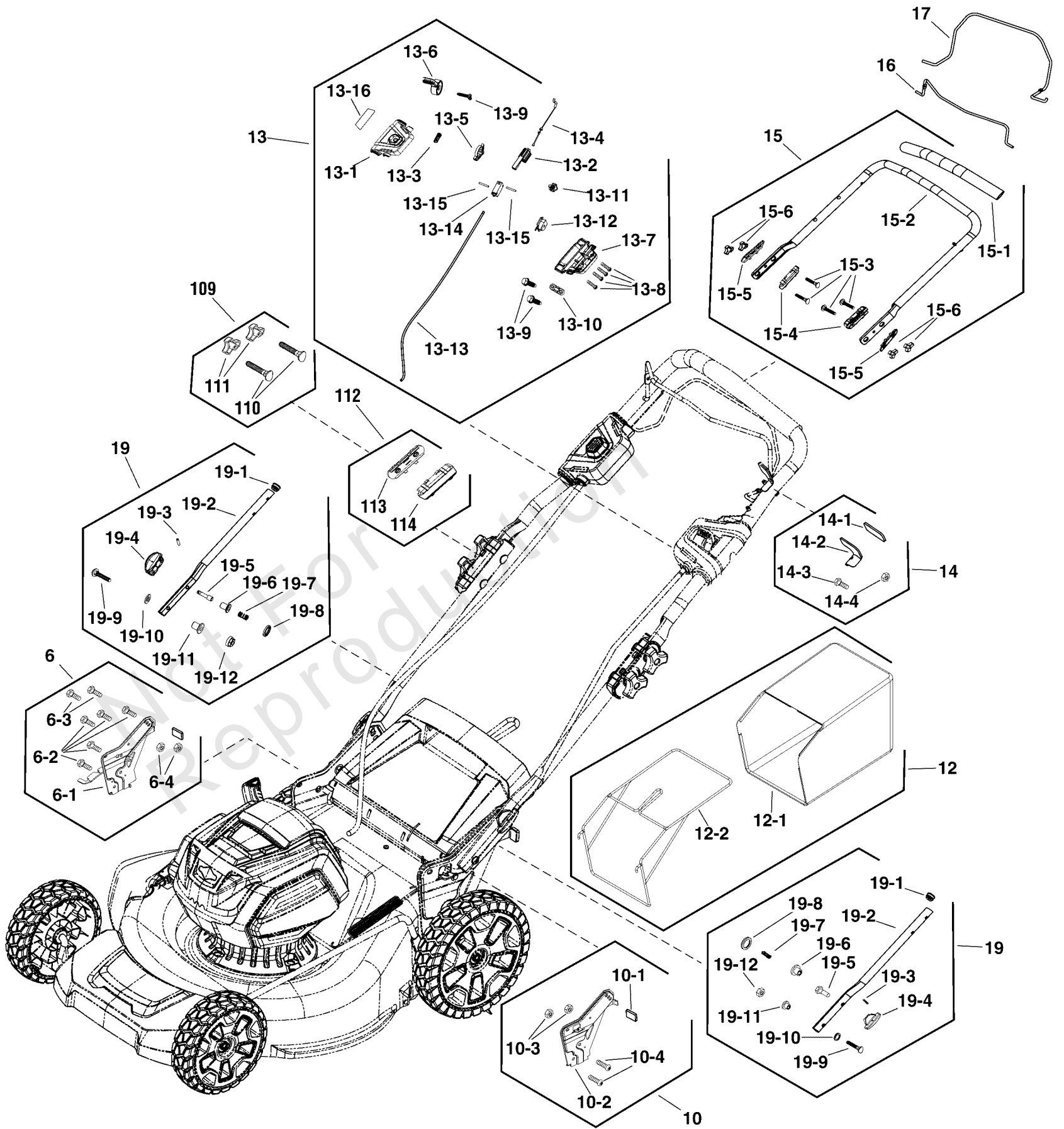

Handles Group

REF NO	PART NO	QTY	DESCRIPTION
6	771636	1	KIT, RIGHT HEIGHT ADJUST
6-1	-----	1	BUMPER
6-2	-----	1	RIGHT HEIGHT ADJUST
6-3	-----	2	BOLT
6-4	-----	2	NUT
10	771588	1	KIT, LEFT HEIGHT ADJUST
10-1	-----	1	BUMPER
10-2	-----	1	BRACKET, Height Adjust
10-3	-----	2	NUT
10-4	-----	2	BOLT
12	770182	1	GRASS CATCHER ASSEMBLY
12-1	-----	1	GRASS BAG
12-2	-----	1	FRAME
13	771590	1	KIT, SPEED CONTROL
13-1	-----	1	SWITCH BOX COVER
13-2	-----	1	SLIDER
13-3	-----	1	SPRING
13-4	84003406	1	CABLE, Bail
13-5	-----	1	SELF-PROPEL GEAR, BIG
13-6	84003407	1	KIT, Speed Control
13-7	-----	1	COVER, Bottom
13-8	-----	4	SCREW ST4.2*25
13-9	-----	3	SCREW ST4.2-16
13-10	-----	1	CLAMP
13-11	-----	1	BLOCK
13-12	-----	1	SELF-PROPEL GEAR, SMALL
13-13	84003408	1	HARNES, SPEED CONTROL
13-14	84003409	1	SWITCH
13-15	84003410	1	PIN. ROLL
13-16	-----	1	LABEL
14	771594	1	KIT, STOP
14-1	-----	1	SPONGE
14-2	-----	1	BRACKET
14-3	-----	1	BOLT M5X35
14-4	-----	1	NUT
15	771612	1	KIT, UPPER HANDLE
15-1	-----	1	GRIP, Foam
15-2	-----	1	HANDLE, UPPER
15-3	-----	4	BOLT M8
15-4	-----	2	HANDLE BRACKET INSIDE
15-5	-----	2	HANDLE BRACKET OUTSIDE
15-6	-----	4	KNOB
16	770169	1	KIT, Bail
17	771596	1	KIT, SELF-PROPELLED LEVER
19	771597	2	KIT, LOWER HANDLE
19-1	-----	1	CAP
19-2	-----	1	HANDLE, Lower
19-3	-----	1	PIN
19-4	-----	1	PIN
19-4	84003399	1	KNOB, RELEASE
19-5	-----	1	ADJUSTMENT PIN

Handles Group

Note: Unless noted otherwise, use the standard torque specifications

Mfg. No: 1687921-00

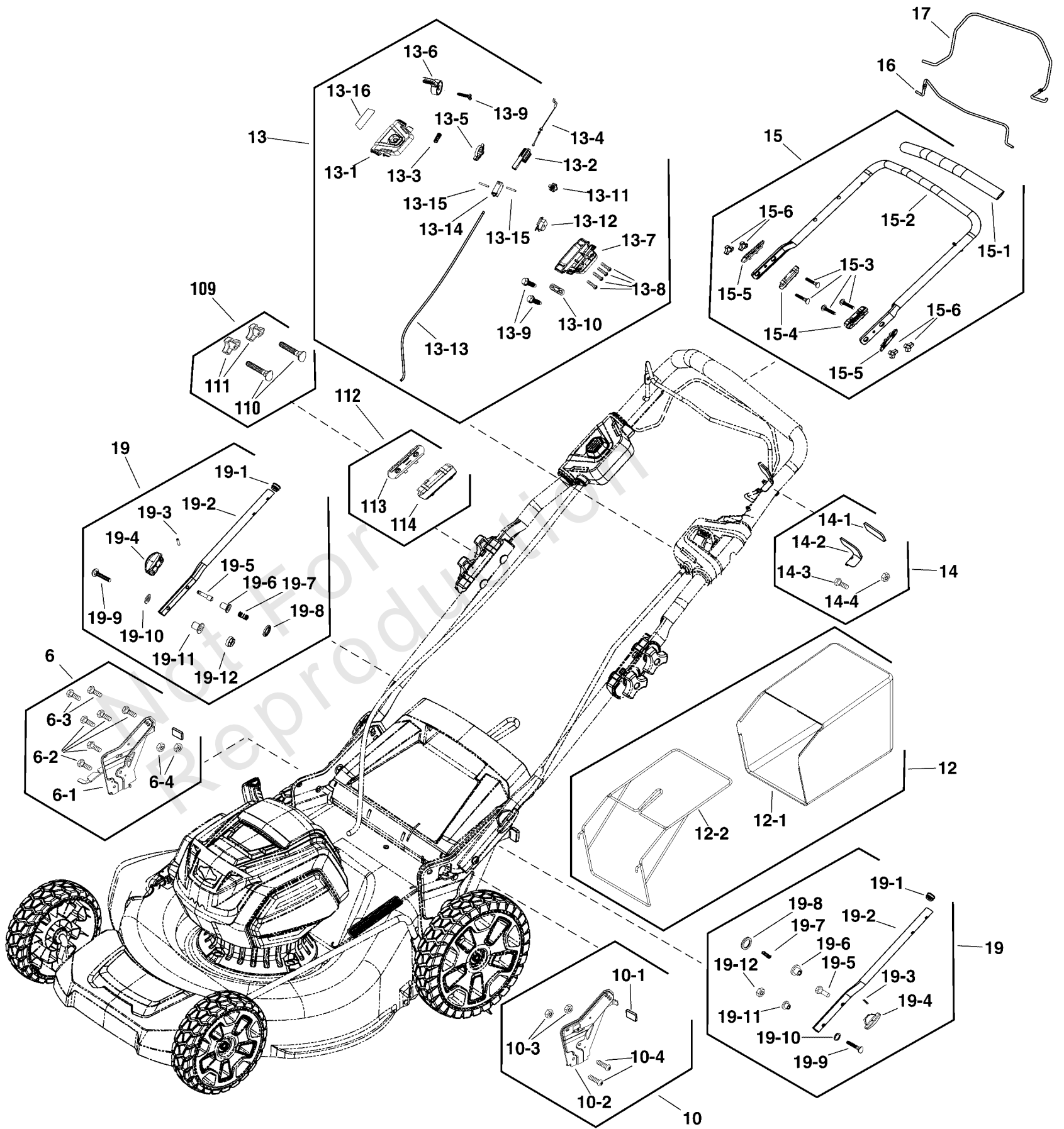

Handles Group

REF NO	PART NO	QTY	DESCRIPTION
19-6	-----	1	BUSHING
19-7	-----	1	SPRING
19-8	-----	1	GASKET
19-9	-----	1	BOLT M8X35
19-10	-----	1	WASHER, Flat
19-11	-----	1	BUSHING
19-12	-----	1	NUT, M8
109	770175	1	KIT, Hardware
110	-----	1	BOLT
111	-----	1	KNOB
112	770176	1	KIT, Handle Bracket
113	-----	1	BRACKET
114	-----	1	BRACKET

Not For Reproduction

Wheels & Deck Group

Note: Unless noted otherwise, use the standard torque specifications

Mfg. No: 1687921-00

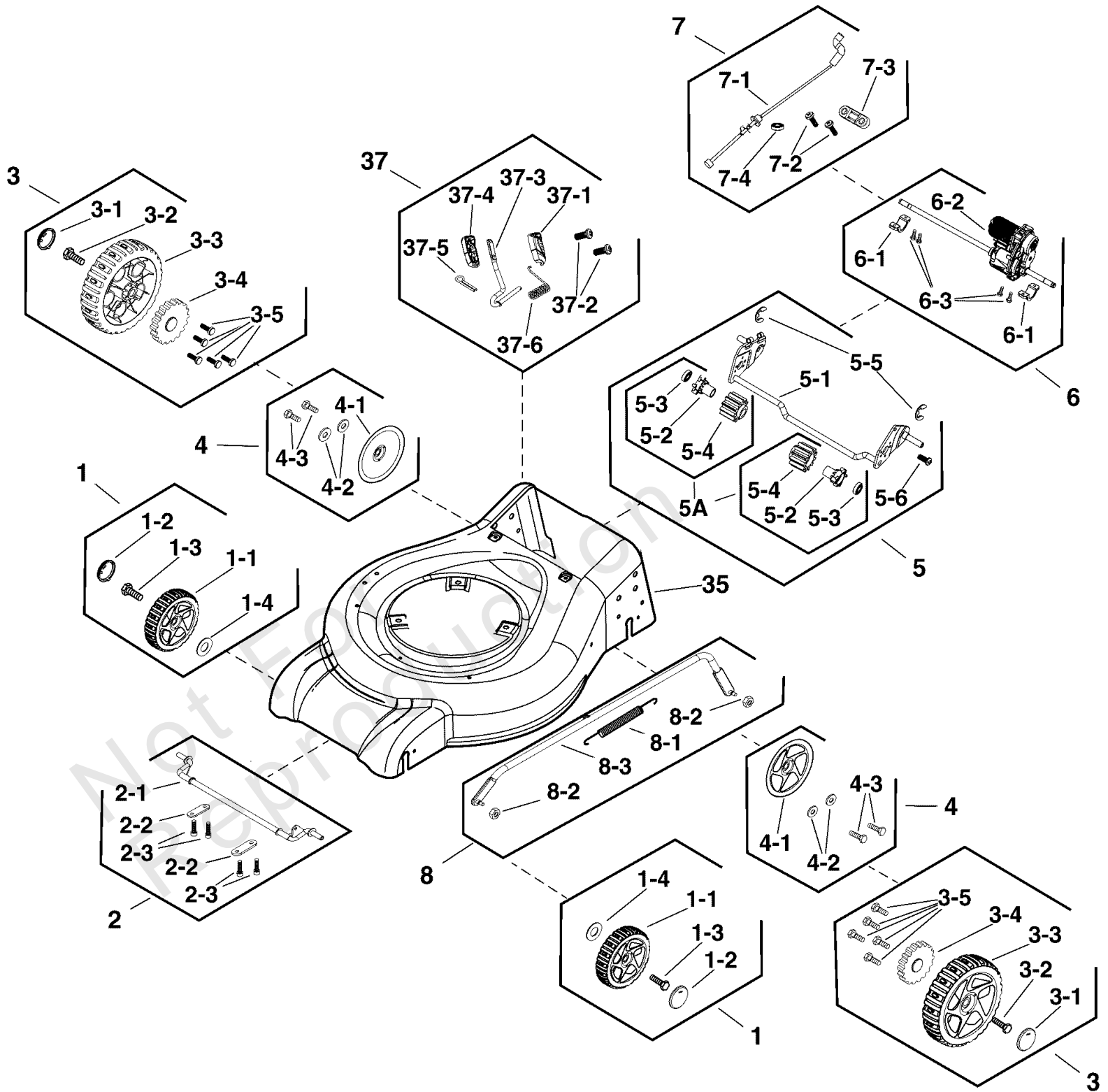

Wheels & Deck Group

REF NO	PART NO	QTY	DESCRIPTION
1	771438	1	KIT, Front Wheel
1-1	-----	1	WHEEL, 8"
1-2	-----	1	WASHER
1-3	-----	1	BOLT
1-4	-----	1	COVER, Wheel
2	770186	1	KIT, Front Axle
2-1	-----	1	SCREW, Pan Torx Self Tap, ST4.2 x 20-C
2-2	-----	1	AXLE, Front
2-3	-----	2	TAB
3	771581	1	KIT, Rear Wheel
3-1	-----	1	COVER, Wheel
3-2	-----	1	BOLT
3-3	-----	1	WHEEL, 10"
3-4	84003415	1	GEAR, Drive
3-5	-----	5	SCREW, Pan Torx Self Tap, ST4.2 x 20-C
4	771582	1	KIT, Dust Cover
4-1	-----	1	DUST COVER
4-2	-----	2	GASKET, 5.3
4-3	-----	2	SCREW ST4.2-16
5	771583	1	KIT, Rear Axle
5A	84003414	1	KIT, Gears
5-1	-----	1	AXLE, REAR
5-2	-----	2	COLLAR, Locking
5-3	-----	2	BEARING
5-4	-----	2	GEAR, Drive
5-5	-----	2	SCREW, Pan Torx Self Tap, ST4.2 x 20-C
5-6	-----	2	SCREW ST4.2-16
6	771584	1	KIT, Gear Box
6-1	-----	2	PLATE, Axle
6-2	-----	1	GEARBOX
6-3	-----	4	SCREW, Pan Torx Self Tap, ST4.2 x 20-C
7	771585	1	KIT, Harness, Self Propelled
7-1	-----	1	MOTOR CABLE
7-2	-----	2	SCREW ST4.2-16
7-3	-----	1	CLAMP
7-4	-----	1	GROMMET
8	771586	1	KIT, Rod, Height Adjust
8-1	-----	1	SPRING
8-2	-----	2	NUT
8-3	-----	1	ROD, Height Adjust
35	771607	1	KIT, Mower Deck
37	771608	1	KIT, Lever, Height Adjust
37-1	-----	1	HOUSING, Left
37-2	-----	2	SCREW ST4.2-12
37-3	-----	1	ROD, Adjusting
37-4	-----	1	HOUSING, Right
37-5	-----	1	PIN, Cotter
37-6	-----	1	SPRING

Hardware Identification & Torque Specifications

Torque Specification Chart								
FOR STANDARD METRIC MACHINE HARDWARE (Tolerance ± 20%)								
Property Class	5.6		8.8		10.9		12.9	
	Class 5.6		Class 8.8		Class 10.9		Class 12.9	
Size Of Hardware	in/lbs		in/lbs		in/lbs		in/lbs	
	ft/lbs	Nm.	ft/lbs	Nm.	ft/lbs	Nm.	ft/lbs	Nm.
M3	5.88	.56	13.44	1.28	19.2	1.80	22.92	2.15
M4	13.44	1.28	30.72	2.90	43.44	4.10	52.56	4.95
M5	26.4	2.50	60.96	5.75	5.97	8.10	7.15	9.7
M6	44.64	4.3	7.3	9.9	10.3	14	12.1	16.5
M7	5.2	7.1	12.1	16.5	16.9	23	19.9	27
M8	7.7	10.5	17.7	24	25	34	29	40
M10	15	21	35	48	50	67	59	81
M12	26	36	61	83	86.2	117	103	140
M14	42	58	101	132	136	185	162	220
M16	64	88	147	200	210	285	250	340
M18	89	121	202	275	287	390	346	470
M20	126	171	290	390	405	550	486	660
M22	169	230	390	530	559	745	656	890
M24	217	295	497	375	708	960	840	1140
M27	320	435	733	995	1032	1400	1239	1680
M30	435	590	995	1350	1401	1900	1681	2280
M33	590	800	1349	1830	1902	2580	2278	3090
M36	759	1030	1740	2360	2441	3310	2935	3980
M39	988	1340	2249	3050	3163	4290	3798	5150

Torque Specification Chart						
FOR STANDARD MACHINE HARDWARE (Tolerance ± 20%)						
Hardware Grade	No Marks		SAE Grade 5		SAE Grade 8	
	SAE Grade 2		SAE Grade 5		SAE Grade 8	
Size Of Hardware	in/lbs		in/lbs		in/lbs	
	ft/lbs	Nm.	ft/lbs	Nm.	ft/lbs	Nm.
8-32	19	2.1	30	3.4	41	4.6
8-36	20	2.3	31	3.5	43	4.9
10-24	27	3.1	43	4.9	60	6.8
10-32	31	3.5	49	5.5	68	7.7
1/4-20	66	7.6	8	10.9	12	16.3
1/4-28	76	8.6	10	13.6	14	19.0
5/16-18	11	15.0	17	23.1	25	34.0
5/16-24	12	16.3	19	25.8	29	34.0
3/8-16	20	27.2	30	40.8	45	61.2
3/8-24	23	31.3	35	47.6	50	68.0
7/16-14	30	40.8	50	68.0	70	95.2
7/16-20	35	47.6	55	74.8	80	108.8
1/2-13	50	68.0	75	102.0	110	149.6
1/2-20	55	74.8	90	122.4	120	163.2
9/16-12	65	88.4	110	149.6	150	204.0
9/16-18	75	102.0	120	163.2	170	231.2
5/8-11	90	122.4	150	204.0	220	299.2
5/8-18	100	136	180	244.8	240	326.4
3/4-10	160	217.6	260	353.6	386	525.0
3/4-16	180	244.8	300	408.0	420	571.2
7/8-9	140	190.4	400	544.0	600	816.0
7/8-14	155	210.8	440	598.4	660	897.6
1-8	220	299.2	580	788.8	900	1,244.0
1-12	240	326.4	640	870.4	1,000	1,360.0

The guides and ruler furnished below are designed to help you select the appropriate hardware.



Nut, M8

Thread Diameter (mm)

Inside Diameter (in) Threads per inch

Nut, 1/2-16



Screw, M8- 1.25 x 25

Thread Diameter (mm) Distance between threads (mm) Body Length (mm)

Body Diameter Threads per inch Body Length (in)

Screw, 1/2- 16 x 2



Standard Hardware Sizing

When a washer or nut is identified as 1/2" (M8), this is the *Nominal size*, meaning the *inside diameter* is 1/2 inch (8mm metric thread diameter); if a second number is present it represents the *threads per inch* (distance between threads).

When bolt or capscrew is identified as 1/2 - 16 x 2" (M8 - 1.25 x 50), this means the *Nominal size*, or body diameter is 1/2 inch (8mm metric thread diameter), the second number, 16, represents the *threads per inch*, (*distance between threads*). The final number is the body length of the bolt or screw, 2 inches (50mm).

NOTES

- These torque values are to be used for all hardware excluding: locknuts, self-tapping screws, thread forming screws, sheet metal screws and socket head setscrews.
- Recommended seating torque values for locknuts:
 - for prevailing torque locknuts - use 65% of grade 5 torques.
 - for flange whizlock nuts and screws - use 135% of grade 5 torques.
- Unless otherwise noted on assembly drawings, all torque values must meet this specification.

Common Hardware Types

Hex Head Capscrew



Washer



Carriage Bolt



Hex Nut

Wrench & Fastener Size Guide

1/4" Bolt or Nut Wrench—7/16"	5/16" Bolt or Nut Wrench—1/2"	3/8" Bolt or Nut Wrench—9/16"	7/16" Bolt or Nut Wrench (Bolt)—5/8" Wrench (Nut)—11/16"	1/2" Bolt or Nut Wrench—3/4"
M6 Bolt or Nut Wrench—10mm	M8 Bolt or Nut Wrench—13mm	M10 Bolt or Nut Wrench—17mm	M12 Bolt or Nut Wrench—19mm	M14 Bolt or Nut Wrench—22mm

