



# Parts Manual

Mfg. No: 2691705-01  
RPX310, 107cm 8270 Series Hydro Drive  
Rear Discharge Tractor



<b>Model Components</b>	<b>Page</b>
42" (107cm) Mower Deck - Clutch Group.....	4
42" (107cm) Mower Deck - Housing, Arbors & Blades Group.....	6
42" (107cm) Mower Deck - Support Group.....	10
Backplate Group.....	12
Collector Group.....	14
Controls Group.....	16
Decals Group.....	18
Electrical Group.....	20
Engine Group.....	22
EU Guard Group.....	24
Frame Group.....	26
Front Axle Group.....	28
Hood, Grille & Dash Group.....	30
Lift Group.....	32
Seat Deck & Fuel Tank Group.....	34
Seat Group.....	36
Steering Group.....	38
Transmission Group - Tuff Torq K46EC.....	40
Transmission SERVICE PARTS - Tuff Torq K46EC (1761877).....	42
Wheels & Tires.....	46
Torque Specification Chart.....	48

Not For  
Reproduction

# 42" (107cm) Mower Deck - Clutch Group

Note: Unless noted otherwise, use the standard torque specifications

Mfg. No: 2691705-01

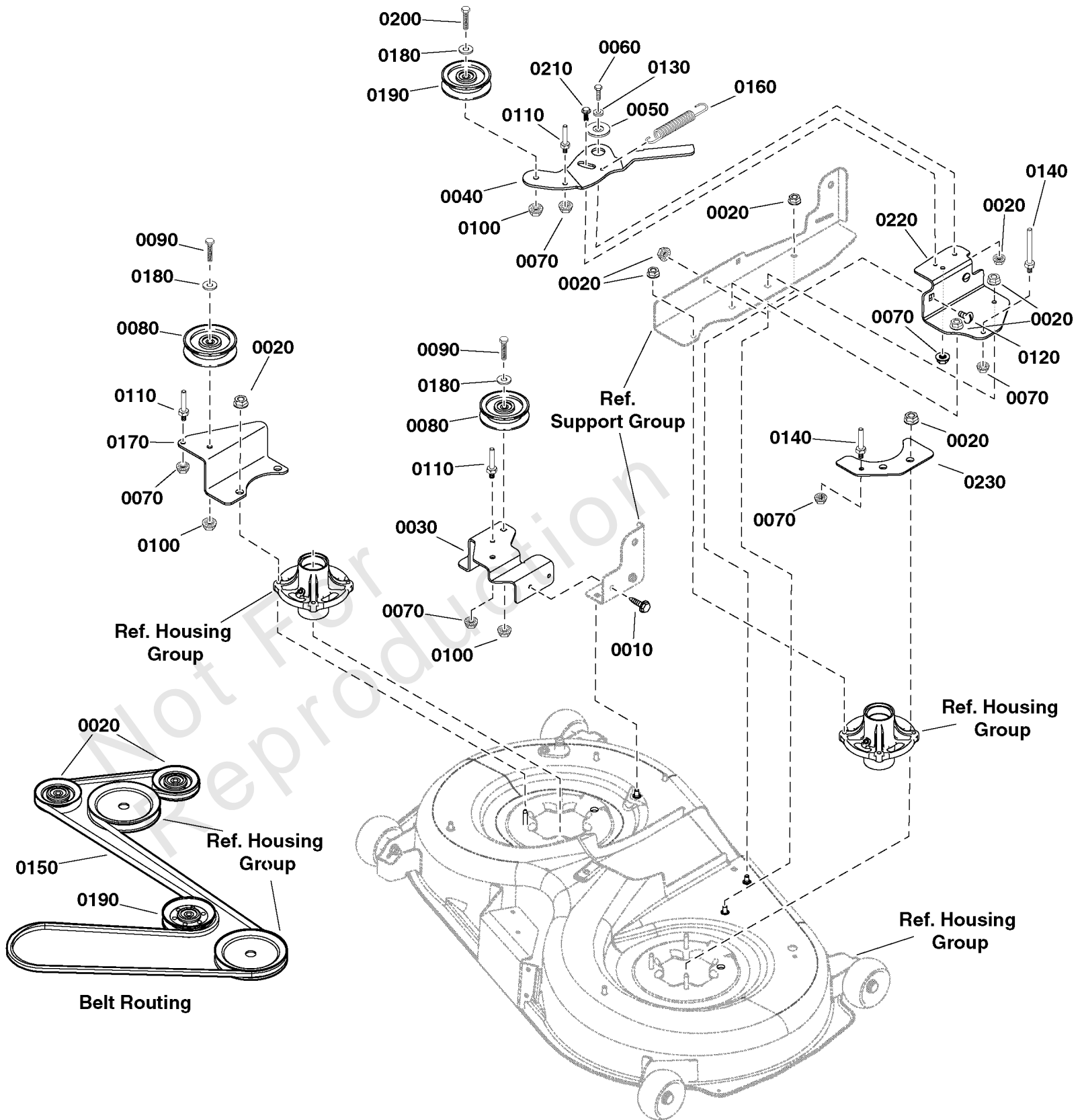

## 42" (107cm) Mower Deck - Clutch Group

REF NO	PART NO	QTY	DESCRIPTION
0010	703228	2	SCREW, 5/16-18 X .75
0020	703409	14	NUT, 5/16-18, GR5
0030	84003049	1	BRACKET, Idler
0040	1758759BMYP	1	IDLER ARM
0050	1727935SM	1	SPACER-PIVOT 0.330ID
0060	703570	1	CAPSCREW, Hex Head, 5/16-18 x 1 1/4
0070	704067	1	NUT, HEX FLNG,5/16-18
0080	885482YP	2	PULLEY, DECK IDLER
0090	703589	2	CAPSCREW, 3/8-16X2
0100	703330	3	NUT, Hex Flange Whiz-Lock, 5/16-18
0110	885534YP	3	BELT GUIDE
0120	703185	3	BOLT, Round Head, Short Square Neck
0130	1919326SM	1	WASHER, 5/16
0140	1401105MA	2	BELT GUIDE, Long
0150	1758760YP	1	BELT
0160	165X157MA	1	SPRING, Extension
0170	885845BMYP	1	BRACKET, Idler, Fixed
0180	704128	3	WASHER
0190	885937YP	1	PULLEY, Idler 4.00
0200	703406	1	CAPSCREW,3/8-16X1.5
0210	1752802YP	1	BOLT, SHLDR, 5/16-18
0220	1758758BMYP	1	BRACKET, Idler Mount
0230	1758757BMYP	1	PLATE, Belt Guide Mount

# 42" (107cm) Mower Deck - Housing, Arbors & Blades Group

Note: Unless noted otherwise, use the standard torque specifications

Mfg. No: 2691705-01

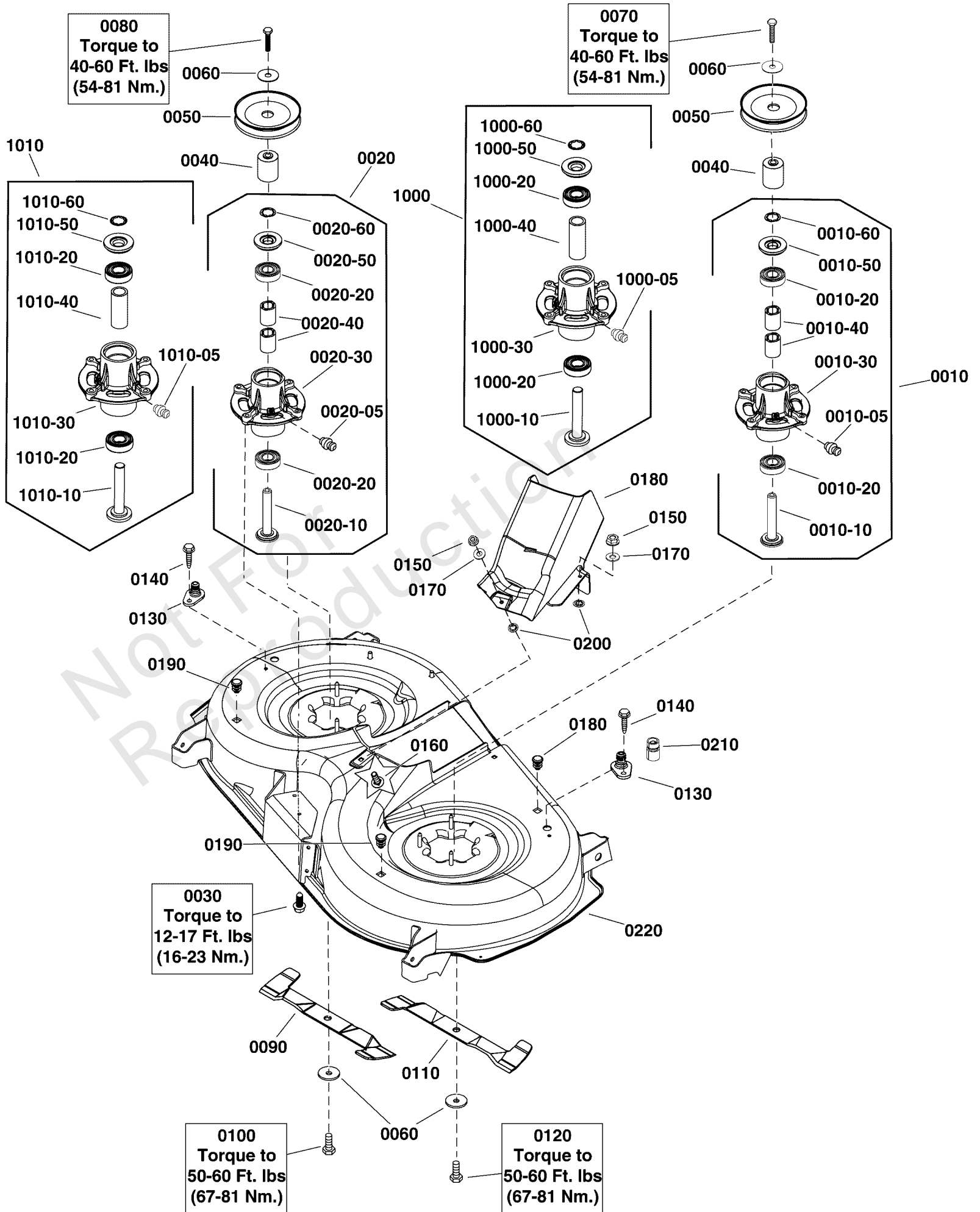

## 42" (107cm) Mower Deck - Housing, Arbors & Blades Group

REF NO	PART NO	QTY	DESCRIPTION
0010	1761015	1	ARBOR ASSEMBLY -(Replaced by Ref. Nos. 1000, this arbor assembly is an exact replacement)
0010-05	1704314SM	1	LUBE FITTING, .250 DR
0010-10	1760276YP	1	SHAFT-SPINDLE -(Replaced by Ref. Nos. 1000-30, this spindle shaft is an exact replacement)
0010-20	1735399YP	2	BEARING, Ball, 20mm
0010-30	1735573YP	1	HOUSING, w/Lube Fitting
0010-40	1735328YP	2	SPACER, Bearing -(Replaced by Ref. Nos. 1000-50, this spacer is an exact replacement)
0010-50	1735323YP	2	SHIELD, Arbor
0010-60	1960766YP	1	RING, SELF LOCKING
1000	84003175	1	ARBOR ASSEMBLY
1000-05	1704314SM	1	LUBE FITTING, .250 DR
1000-10	84003654	1	HOUSING ASSEMBLY
1000-20	1735399YP	2	BEARING, Ball, 20mm
1000-30	84003170	1	SHAFT, SPINDLE
1000-40	84003166	1	COVER, ARBOR
1000-50	84003167	1	SPACER, BEARING
1000-60	1960766YP	1	RING, SELF LOCKING
0020	84003043	1	ARBOR ASSEMBLY, RH -(Replaced by Ref. Nos. 1010, this arbor assembly is an exact replacement)
0020-05	1704314SM	1	LUBE FITTING, .250 DR
0020-10	84003044	1	SHAFT, Spindle -(Replaced by Ref. Nos. 1010-30, this spindle shaft is an exact replacement)
0020-20	1735399YP	2	BEARING, Ball, 20mm
0020-30	1735573YP	1	HOUSING, w/Lube Fitting
0020-40	1735328YP	2	SPACER, Bearing -(Replaced by Ref. Nos. 1010-50, this spacer is an exact replacement)
0020-50	1735323YP	2	SHIELD, Arbor
0020-60	1960766YP	1	RING, SELF LOCKING
1010	84003176	1	ARBOR ASSEMBLY
1010-05	1704314SM	1	LUBE FITTING, .250 DR
1010-10	84003171	1	SHAFT, Spindle
1010-20	1735399YP	2	BEARING, Ball, 20mm
1010-30	84003654	1	HOUSING ASSEMBLY
1010-40	84003167	1	SPACER, BEARING
1010-50	84003166	1	COVER, ARBOR
1010-60	1960766YP	1	RING, SELF LOCKING
0030	704318	8	SCREW, 5/16-18X1-1/2
0040	1750338YP	2	SPACER, Mower Drive
0050	1758750YP	2	PULLEY
0060	1656916SM	4	WASHER, SPRING 0.475I
0070	1926110SM	1	CAPSCREW-HEX HD 7/16-
0080	703846	1	SCREW, 7/16-14X2.75
0090	1758513BMYP	1	BLADE, RH
0100	703845	1	SCREW, 7/16-14X1
0110	1758514BMYP	1	BLADE, LH
0120	1920676SM	1	CAPSCREW, Hex Head, 7/16-14 X 1
0130	1756247YP	2	ADAPTER, Washout Port
0140	703228	2	SCREW, 5/16-18 X .75
0150	703409	3	NUT, 5/16-18, GR5
0160	703800	3	BOLT, CRRG, 5/16-18X1
0170	1919326SM	3	WASHER, 5/16

# 42" (107cm) Mower Deck - Housing, Arbors & Blades Group

Note: Unless noted otherwise, use the standard torque specifications

Mfg. No: 2691705-01

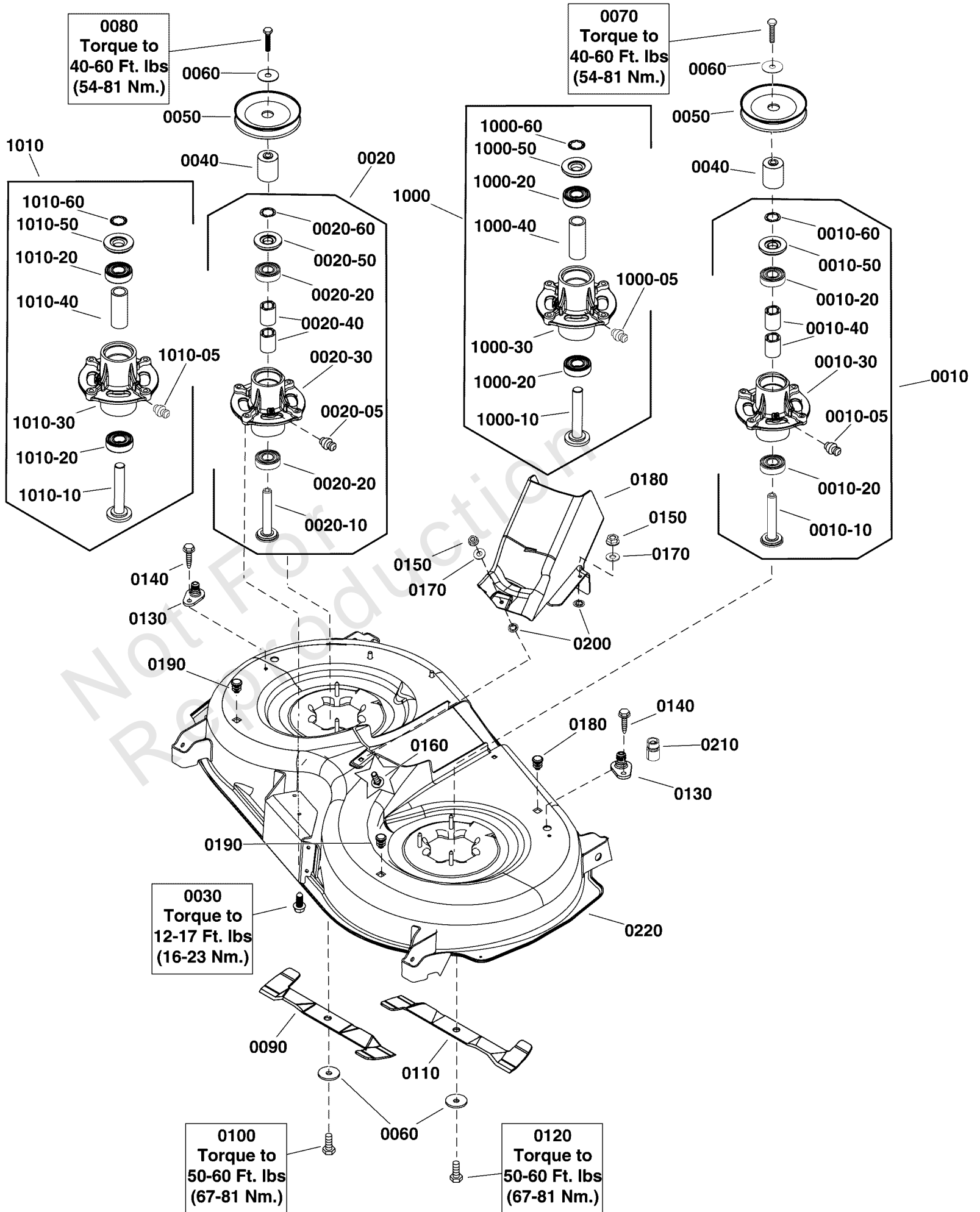



## 42" (107cm) Mower Deck - Housing, Arbors & Blades Group

REF NO	PART NO	QTY	DESCRIPTION
0180	885719YP	1	CENTER CAP
0190	7046780SM	3	PLUG, Hole, .44" OD
0200	703297	3	RETAINER, GR5, 5/16
0210	1756246YP	1	CONNECTOR, Washout Port
0220	885827BMYP	1	KIT, Mower Deck 107cm, Crow Black

Not For Reproduction

# 42" (107cm) Mower Deck - Support Group

Note: Unless noted otherwise, use the standard torque specifications

Mfg. No: 2691705-01

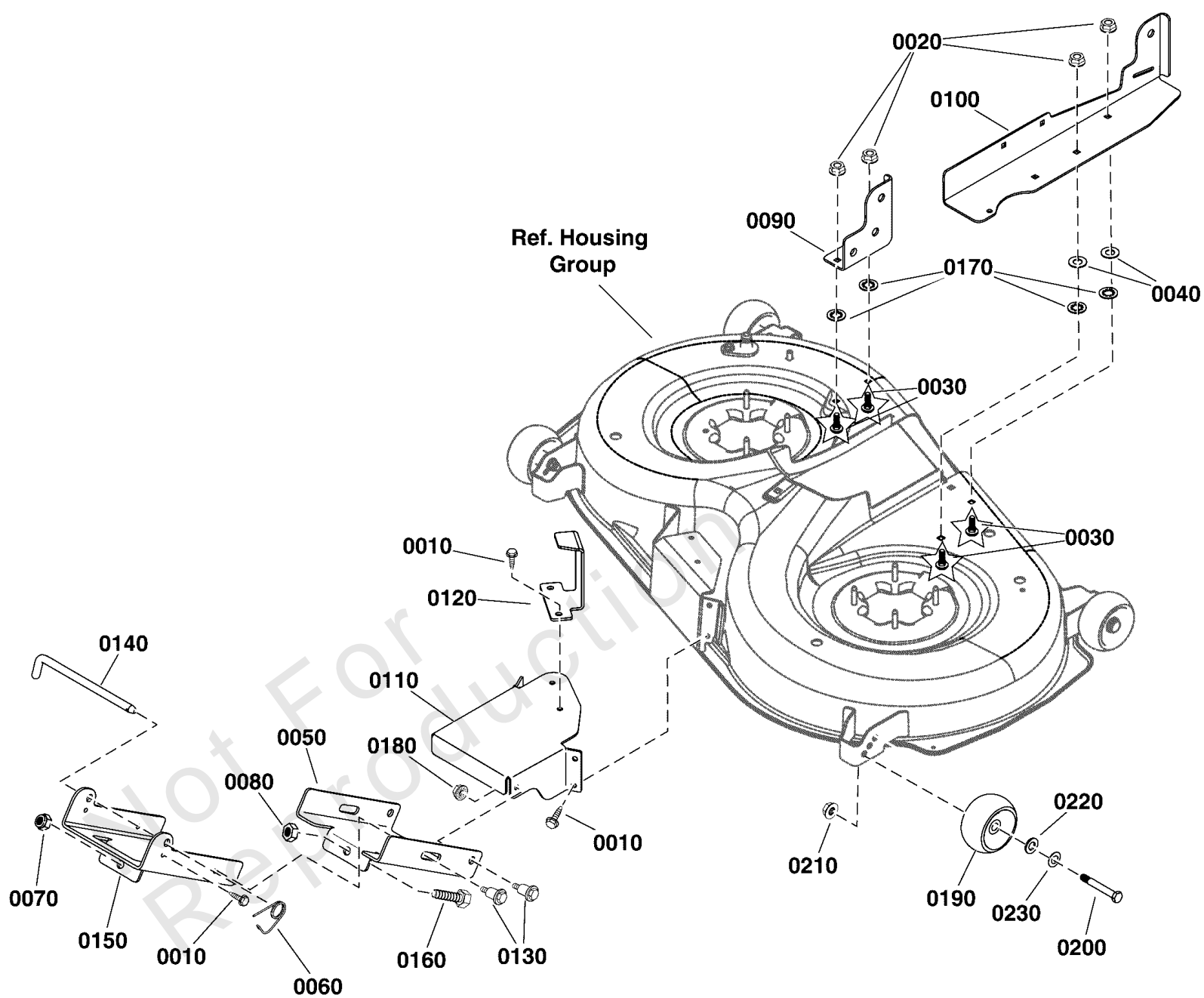

## 42" (107cm) Mower Deck - Support Group

REF NO	PART NO	QTY	DESCRIPTION
0010	703228	8	SCREW, 5/16-18 X .75
0020	703409	4	NUT, 5/16-18, GR5
0030	703800	4	BOLT, CRRG, 5/16-18X1
0040	1919326SM	2	WASHER, 5/16
0050	885734BMYP	1	BRACKET, Front Connector
0060	703852	1	PIN, 5/16 X 0.375
0070	1960379SM	1	NUT, Hex Lock, 1/2-13
0080	1913744SM	1	NUT, Hex Jam, 1/2-13
0090	885720BMYP	1	BRACKET, Deck, Rear, RH
0100	885724BMYP	1	BRACKET, Deck, Rear Lift, LH
0110	885727BMYP	1	SUPPORT, Front
0120	84003051	1	UPSTOP
0130	1732426SM	4	BOLT-SHLDR 5/16-18 0.
0140	1731414SM	1	ROD, Latch, 9"
0150	885699BMYP	1	BRACKET, Front Hanger
0160	885710YP	1	BOLT, 1/2 x 3
0170	703297	4	RETAINER, GR5, 5/16
0180	703115	4	NUT
0190	1714760SM	2	GAUGE WHEEL
0200	2108765SM	2	BOLT-WHEEL 3/8-16X2.7
0210	703158	2	NUT, Hex Flange, 3/8-16
0220	703853	2	WASHER, 0.516IDX1OD
0230	0020X3MA	2	WASHER,SPRING .52X.99

# Backplate Group

Note: Unless noted otherwise, use the standard torque specifications

Mfg. No: 2691705-01

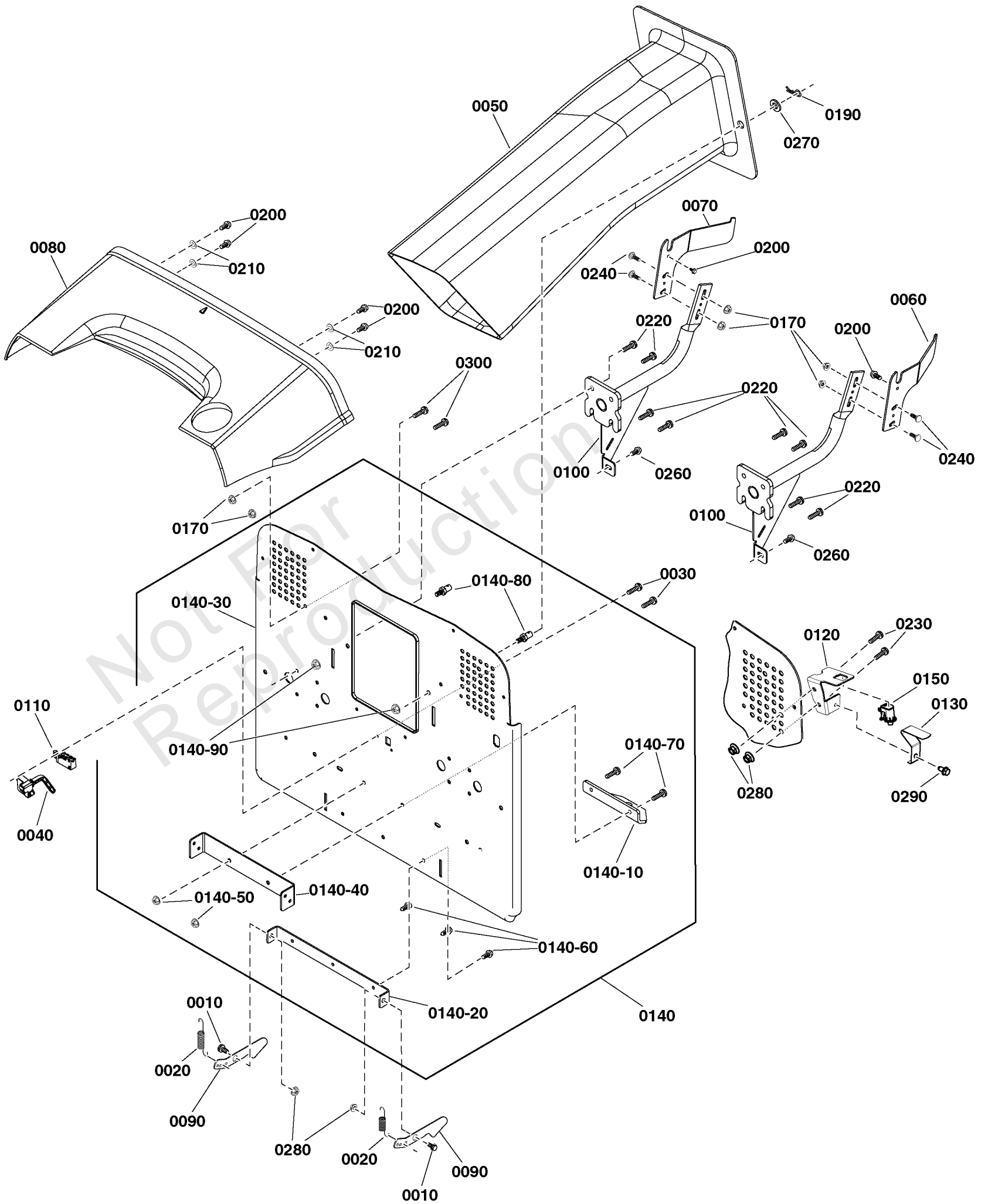

## Backplate Group

REF NO	PART NO	QTY	DESCRIPTION
0010	009X39MA	2	BOLT, Shoulder, 3/8-16 x 1/2
0020	165X75MA	2	SPRING, Extension
0030	880760YP	2	SCREW, #10-14 x .88, Plastite
0040	885618YP	1	COVER, Bag Full Switch
0050	84003003	1	CHUTE, 42"
0060	885852BMYP	1	PLATE, Rotation, LH
0070	885853BMYP	1	PLATE, Rotation, RH
0080	1758498YP	1	TRANSITION PIECE
0090	1758530BMYP	2	LATCH
0100	1758925BMYP	2	SUPPORT, Bagger
0110	84003064	1	SWITCH, Bag Full
0120	84003066	1	BRACKET, Bag Present
0130	1755620AYP	1	ACTUATOR, Switch
0140	84003063	1	BACKPLATE ASSEMBLY
0140-10	885862YP	1	KIT TOWBRKT
0140-20	885497AYP	1	BRACKET, Bagger Latch
0140-30	-----	1	Back Plate -( Not Serviceable )
0140-40	84003055	1	BRACKET, Support
0140-50	703409	2	NUT, 5/16-18, GR5
0140-60	703228	3	SCREW, 5/16-18 X .75
0140-70	703410	2	BOLT,5/16-18X1
0140-80	704054	2	PIN, 3/8-16
0140-90	703893	2	NUT, CNTR LCK, 3/8-16
0150	7023354YP	1	SWITCH, SEAT
0170	703409	10	NUT, 5/16-18, GR5
0190	703300	2	PIN, 3/32 X 1.6
0200	703228	10	SCREW, 5/16-18 X .75
0210	1919326SM	4	WASHER, 5/16
0220	703167	8	SCREW
0230	703237	2	CAPSCREW, 3/8-16X.75
0240	703185	4	BOLT, Round Head, Short Square Neck
0260	703410	2	BOLT,5/16-18X1
0270	703853	2	WASHER, 0.516IDX1OD
0280	703893	4	NUT, CNTR LCK, 3/8-16
0290	703949	1	SCREW, 5/16-18.625
0300	703354	4	SCREW, 5/16-18

# Collector Group

Note: Unless noted otherwise, use the standard torque specifications

Mfg. No: 2691705-01

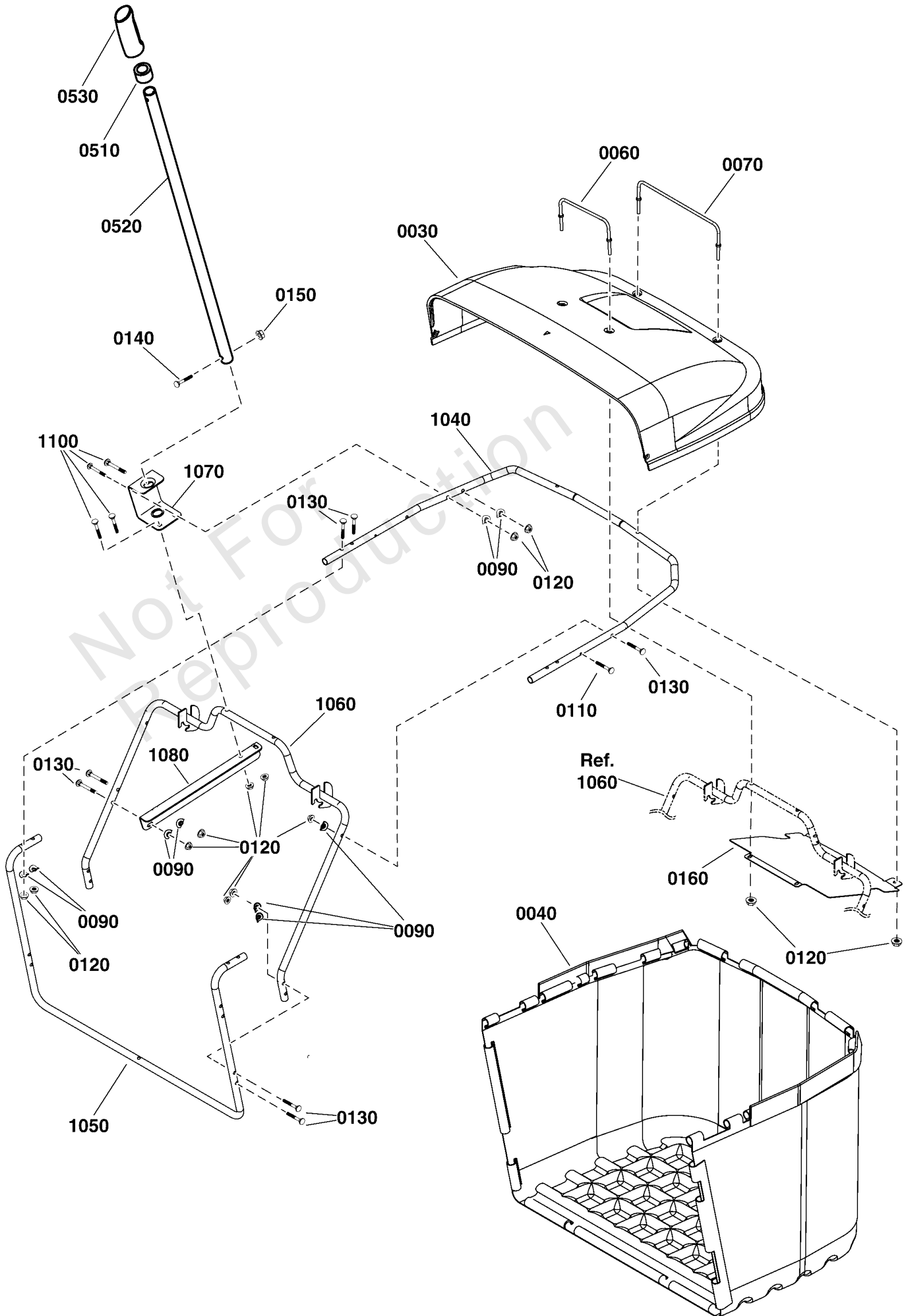

## Collector Group

REF NO	PART NO	QTY	DESCRIPTION
0030	1758510YP	1	COVER, Collector
0040	1758532YP	1	BAG, Collector
0060	84002986	1	HANDLE, Front
0070	84002988	1	HANDLE, Back
0090	880615YP	14	WASHER
0110	885564YP	2	SCREW, Torx, 1/4-20
0120	703115	20	NUT
0130	706883	12	SCREW, 5/16-18 x 2
0140	001X94MA	1	BOLT, Hex, 1/4-20 x 1-1/4
0150	015X89MA	1	NUT .25-20 FLANGELOCK
0160	1758926BMYP	1	SHIELD, Collector
0510	885433YP	1	ADJUSTER, Handle
0520	885518AYP	1	HANDLE, Bagger
0530	1723359SM	1	GRIP
1040	1758255BMYP	1	FRAME, Bagger Support, Upper
1050	1758256BMYP	1	FRAME, Bagger Support, Front
1060	1758329BMYP	1	FRAME, Bagger Support
1070	1758357BMYP	1	SUPPORT, Dump Handle
1080	1758659BMYP	1	BRACKET Dump Handle
1100	703296	4	BOLT, 5/16-18X1.5

# Controls Group

Note: Unless noted otherwise, use the standard torque specifications

Mfg. No: 2691705-01

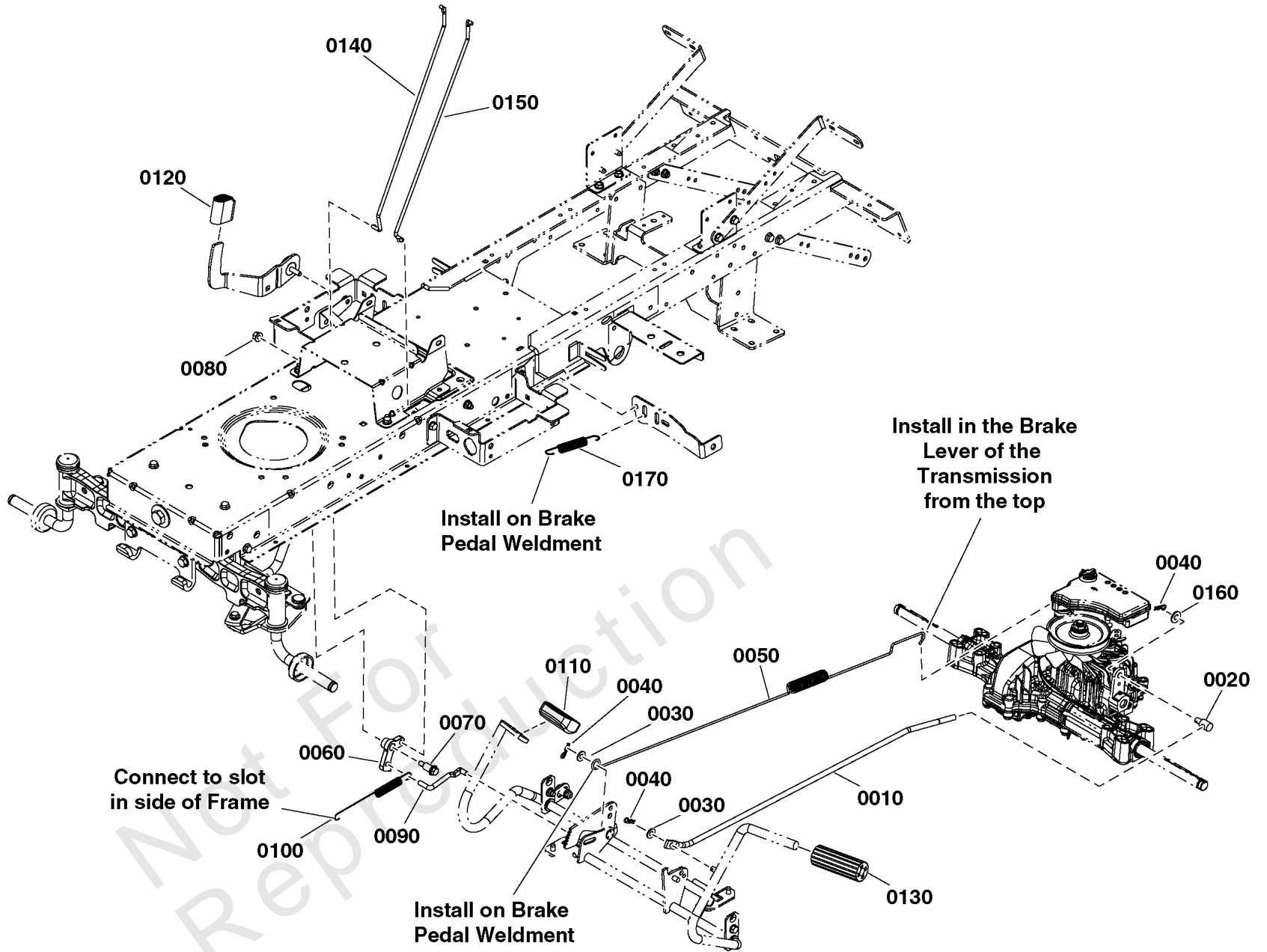



## Controls Group

REF NO	PART NO	QTY	DESCRIPTION
0010	84002680	1	ROD
0020	84002684	1	NUT, Adjustment
0030	1919326SM	2	WASHER, 5/16
0040	703430	3	PIN, 13X1.19
0050	84002686	1	SPRING, Brake
0060	1727897SM	1	LATCH, Cruise
0070	1728976SM	1	BOLT, Shoulder, 5/16-18 x 1-5/8
0080	703115	1	NUT
0090	1727899SM	1	ROD, Cruise Latch, 5/16 Dia. x 2-13/16 Long
0100	2159181SM	1	SPRING, Extension, 9/16 OD x 7-3/4
0110	1721675SM	1	PAD, Foot Pedal, Forward
0120	1727259SM	1	PAD, Foot Pedal, Reverse
0130	1727261SM	1	PEDAL-BRAKE BLACK RUB
0140	1739877YP	1	ROD, Cruise Latch, 1/4 Dia. x 17
0150	1739876YP	1	ROD, Parking Brake, 1/4 Dia. x 16-3/8 Long
0160	703878	1	WASHER, FLAT
0170	84002687	1	SPRING, Extension

# Decals Group

Note: Unless noted otherwise, use the standard torque specifications

Mfg. No: 2691705-01

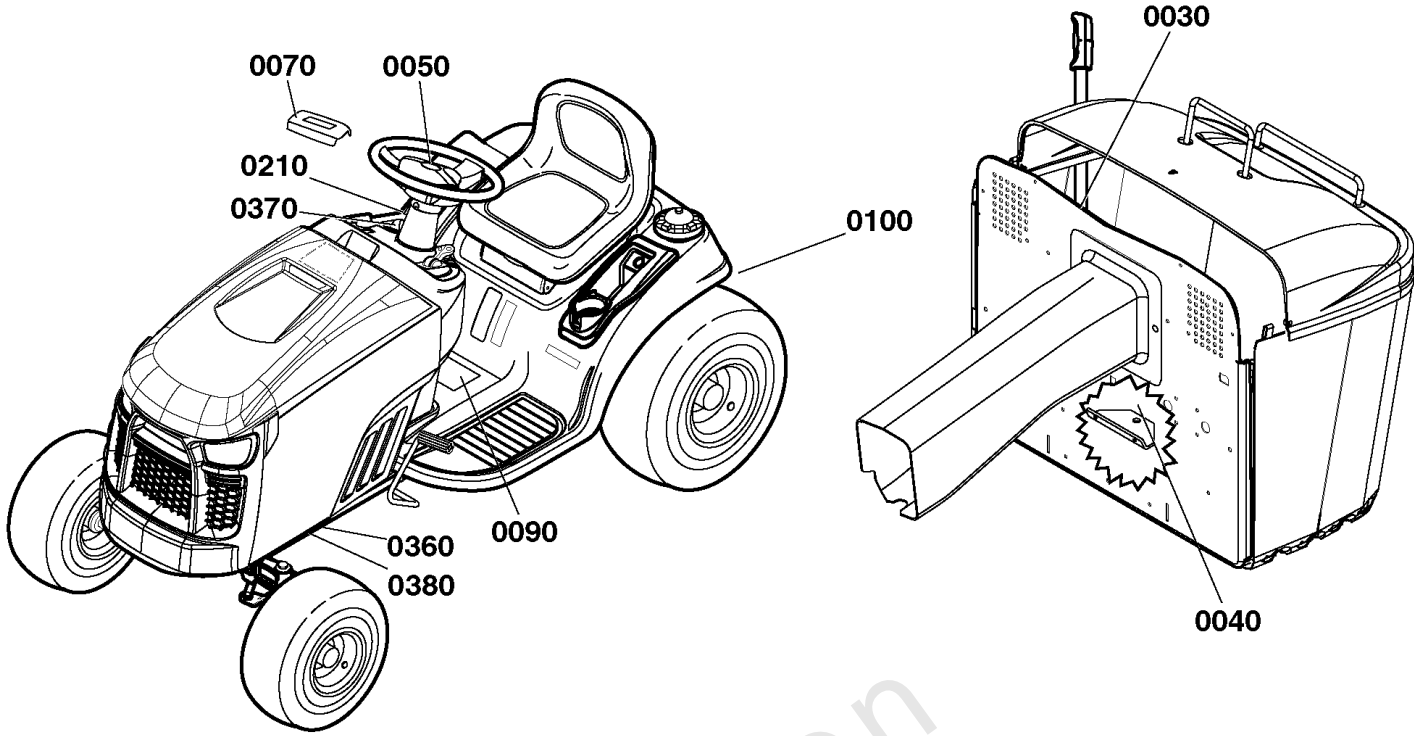

0050



0210



0370



0030

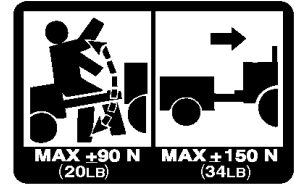

0040

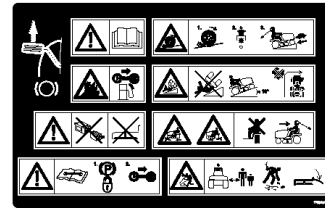

0090



0100

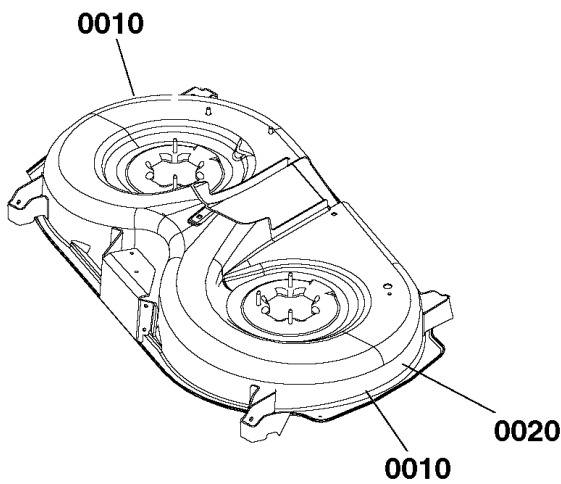

0360



0380

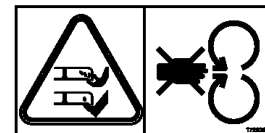

0010

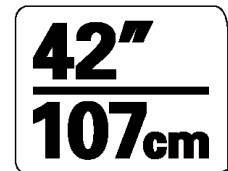

0020

## Decals Group

REF NO	PART NO	QTY	DESCRIPTION
0010	1720389SM	2	DECAL-DANGER ROTATING
0020	1755716YP	1	DECAL, 42"/107cm
0030	1721107SM	1	DECAL, Danger Discharge Tube, Symbols
0040	48X511MA	1	DECAL, Drawbar Warning Symbol
0050	84002249	1	DECAL, Snapper Logo, 3.1" X .8"
0070	84002250	1	CAP, Steering Wheel
0090	1750191YP	1	DECAL, Tunnel, Export
0100	1730202SM	1	DECAL, Transmission Tow / Release Lever
0210	1754246YP	1	DECAL, Powered by Briggs
0360	709953	1	DECAL, EAC Compliance
0370	84002996	1	DECAL, Model -( RPX310 )
0380	706112	1	LABEL, Solely For Export - Exempt US Emissions

Not For Reproduction

# Electrical Group

Note: Unless noted otherwise, use the standard torque specifications

Mfg. No: 2691705-01

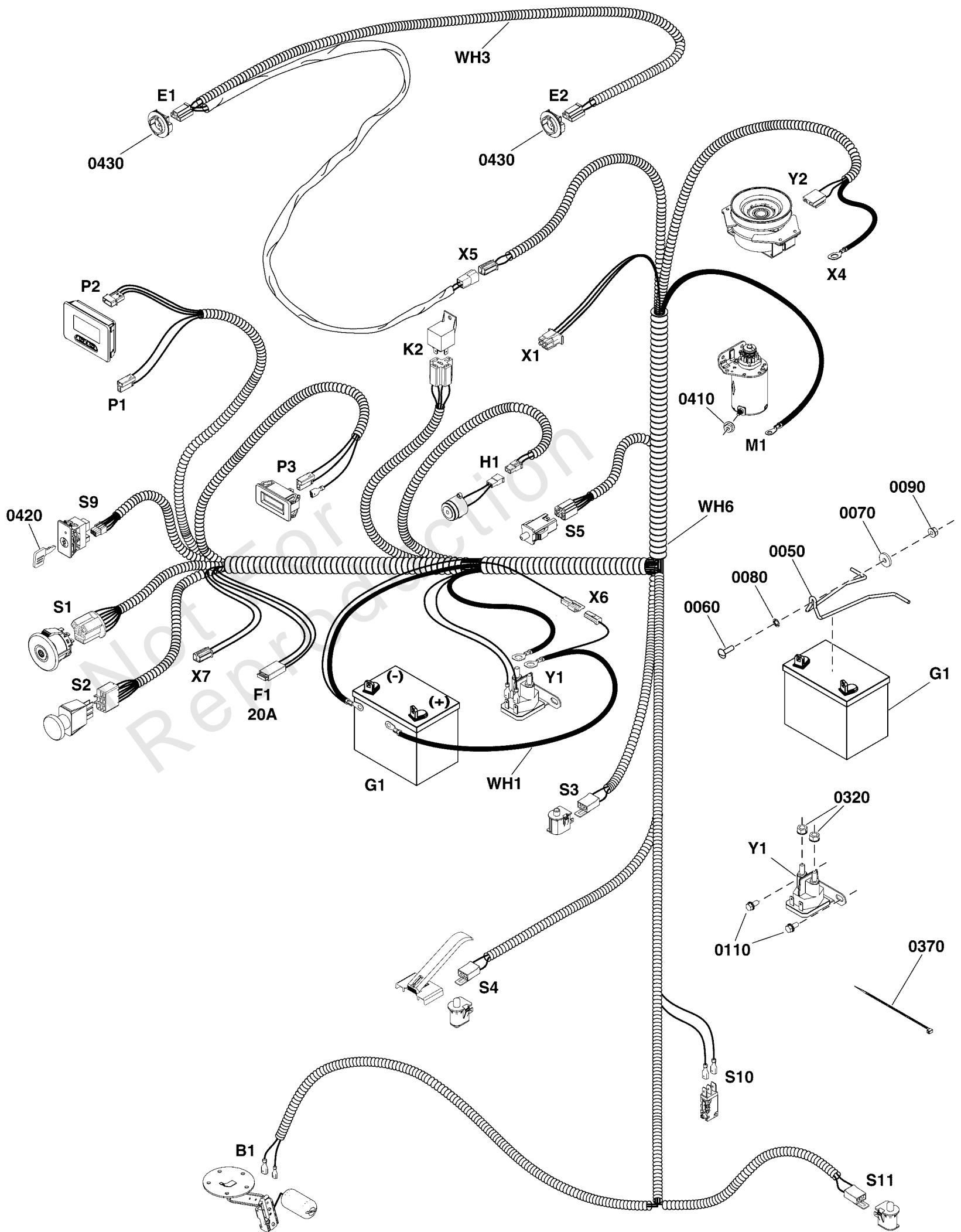

## Electrical Group

REF NO	PART NO	QTY	DESCRIPTION
B1	1758611YP	1	SENDER, Fuel
E1	-----	1	HEADLIGHT, Left
E2	-----	1	HEADLIGHT, Right
F1	1731957SM	1	FUSE, Wiring Harness
G1	-----	1	BATTERY, 12 Volt, 230 CCA
H1	1758779YP	1	BUZZER, Bag Full
K2	1726829SM	1	RELAY(S)
M1	592599	1	MOTOR, Starter
P1	-----	1	CONNECTOR, Hour Meter -(Not Used)
P2	1758654YP	1	DISPLAY, Mini Meter
P3	1758683YP	1	GAUGE, Fuel
S1	1761507YP	1	SWITCH, Ignition
S2	1722887YP	1	SWITCH, PTO Push/Pull, Yel Knob w/Symbols, 8 Terminal
S3	1720411SM	1	SWITCH, NO, Black, Push Button W/Boot -(Reverse Switch)
S4	1738015YP	1	SWITCH, Seat -(Used With Mesh Seat)
S4	7023354YP	1	SWITCH, SEAT
S5	7022886YP	1	SWITCH, DP NO/NC SNAP -(Brake Pedal Switch)
S9	1761897YP	1	SWITCH, Reverse Mow Option
S10	84003064	1	SWITCH, Bag Full
S11	7023354YP	1	SWITCH, SEAT
WH1	1759779YP	1	HARNESS, Battery, Solenoid
WH3	1761298YP	1	HARNESS, Headlight
WH6	84002998	1	HARNESS, Main
X1	-----	1	CONNECTOR, Engine
X4	-----	1	CHASSIS GROUND POINT
X5	-----	1	CONNECTOR, Main Harness to Headlight Harness
X6	-----	1	CONNECTOR, Battery Solenoid Harness to Main Harness
X7	-----	1	CONNECTOR, Main Harness to Height of Cut Harness -(Not Used)
Y1	1755381YP	1	SOLENOID, L-BRACKET -(Starter Solenoid)
Y2	84002545	1	CLUTCH, Ogura, Offset -(PTO Clutch)
0050	1730007SM	1	HOLD DOWN, Battery, 1/4 Dia.
0060	1931318SM	1	BOLT, Carriage, Short Neck, 1/4-20 x 7/8 G5
0070	703229	1	WASHER, 1/4
0080	703826	1	BOLT, PUSHNUT 1/4
0090	703463	1	NUT, GR5,1/4-20
0110	704130	2	SCREW, HEX, 1/4-20X.5
0320	2860750SM	2	NUT-HEX KEPS 5/16-24
0370	703586	3	TIE, SELF LOCKING
0410	703061	1	NUT, HEX KEPS, 1/4-20
0420	1726557SM	2	KEY, No Mow Module (Yellow)
0430	1760239YP	2	LED HEADLIGHT AND SOCKET ASSEMBLY

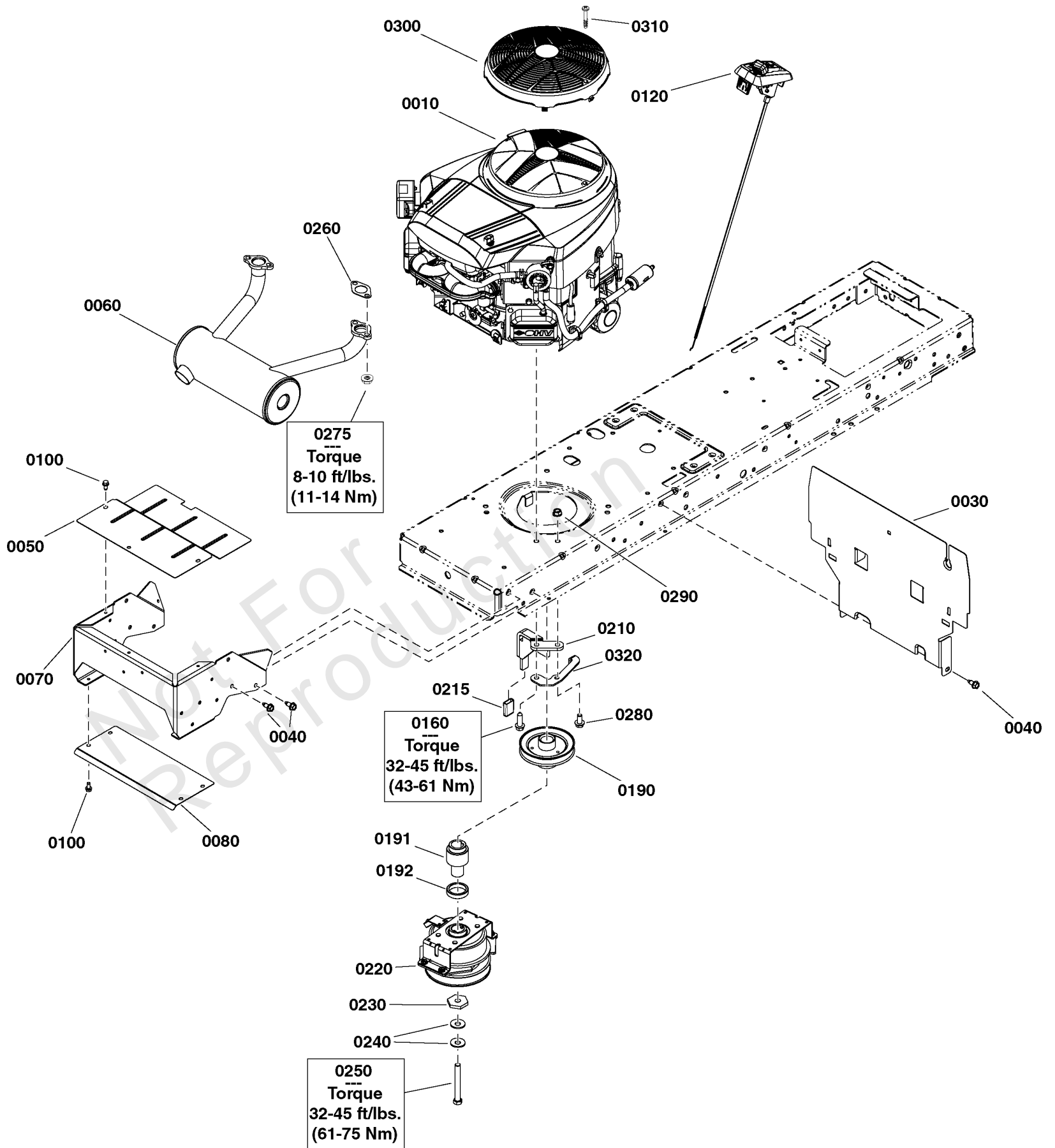

## Engine Group

REF NO	PART NO	QTY	DESCRIPTION
0010	44U877-0028-B5	1	* ENGINE, Briggs & Stratton Twin, Pro Series. Mod. 44U877-0028-B5 -( Engine Model: 44U877-0028-B5 )
0030	1738380AYP	1	HEAT SHIELD, Engine
0040	703228	6	SCREW, 5/16-18 X .75
0050	1761064CJYP	1	HEAT SHIELD
0060	1761127YP	1	MUFFLER, Twin
0070	1761211CJYP	1	Support, Muffler
0080	1761063CJYP	1	HEAT SHIELD, Bottom
0100	704130	7	SCREW, HEX, 1/4-20X.5
0120	1759240YP	1	THROTTLE
0160	704010	4	SCREW, HEX, 3/8-16
0190	84002520	1	PULLEY, Engine
0191	885679YP	1	SPACER, Electric Clutch
0192	885810YP	1	SPACER, Electric Clutch, Lower
0210	84002532	1	ANCHOR, Clutch
0215	84002544	1	Sleeve, Clutch Anchor
0220	84002545	1	CLUTCH, Ogura, Offset
0230	1708264SM	1	WASHER, HEX, 0.453ID
0240	1960769YP	2	WASHER, Belleville
0250	7102075YP	1	CAPSCREW, Hex Head, 7/16-20 x 5, G5
0260	690970	2	GASKET, Exhaust
0275	690941	4	NUT
0280	703955	1	BOLT, 3/8-16X0.75
0290	703333	1	NUT, 3/8-16
0300	797420YP	1	GUARD, Debris Screen
0310	799359	1	SCREW
0320	84004015	1	GUIDE, Belt

---

### Footnotes:

Note:\* Verify your specific engine model, reference the ID Tag located on your engine. Refer to your local Briggs & Stratton distributor for parts and service.

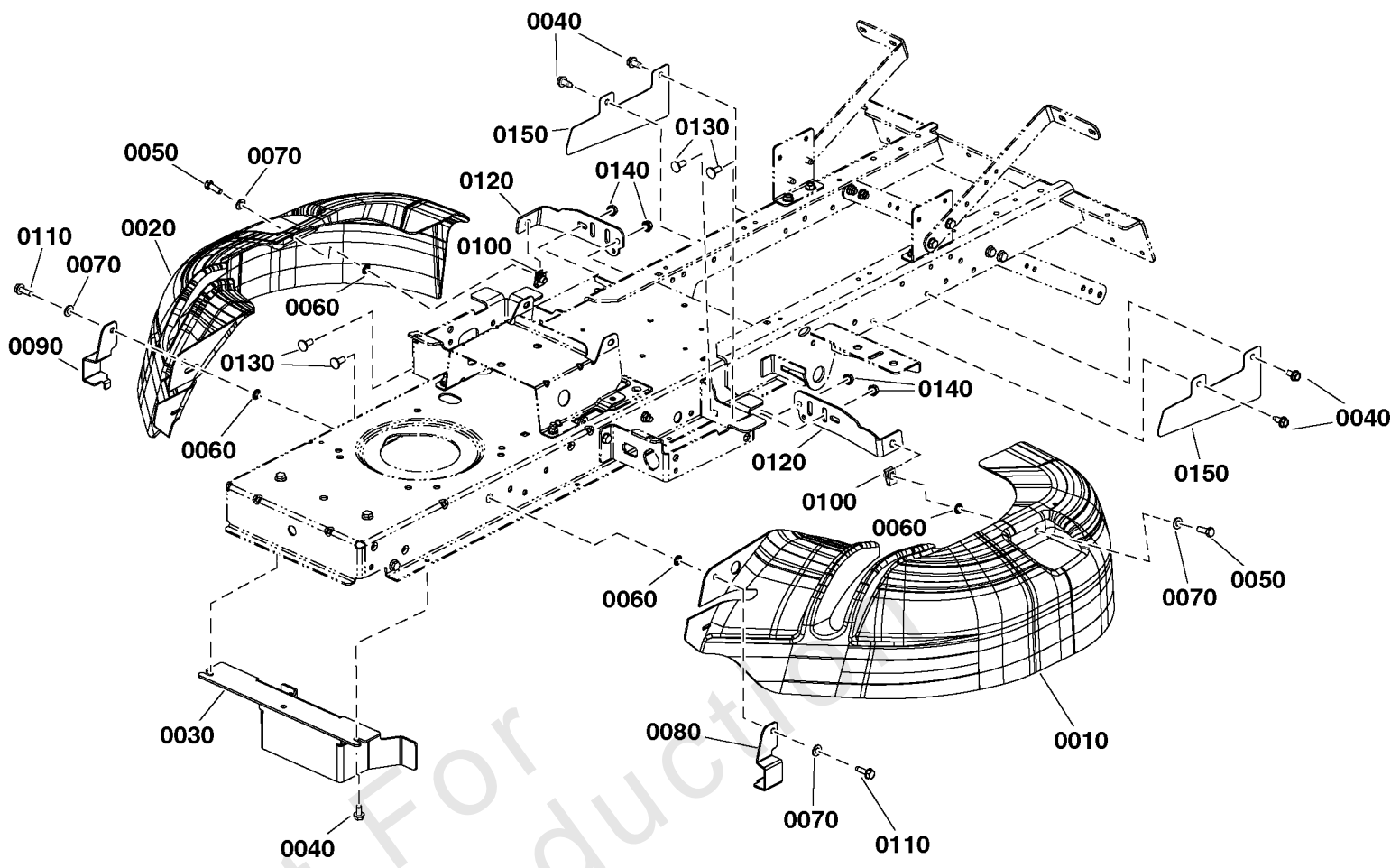



## ***EU Guard Group***

<b>REF NO</b>	<b>PART NO</b>	<b>QTY</b>	<b>DESCRIPTION</b>
0010	1759737YP	1	GUARD, Front, LH
0020	1759738YP	1	GUARD, Front, RH
0030	84003099	1	GUARD, Clutch
0040	703228	6	SCREW, 5/16-18 X .75
0050	703408	2	CAPSCREW, 5/16-18
0060	772145	4	KIT, Bearing Mounting Plate
0070	703350	4	WASHER
0080	1759985BMYP	1	SUPPORT, Guarding, L.H.
0090	1759989BMYP	1	SUPPORT, Guarding, R.H.
0100	1935255SM	2	NUT, SPEED, 5/16-18 L
0110	704146	2	SCREW, HEX, 5/16-18X1
0120	1759729CJYP	2	SUPPORT
0130	703185	4	BOLT, Round Head, Short Square Neck
0140	703409	4	NUT, 5/16-18, GR5
0150	84003101	2	GUARD

Not For Reproduction

# Frame Group

Note: Unless noted otherwise, use the standard torque specifications

Mfg. No: 2691705-01

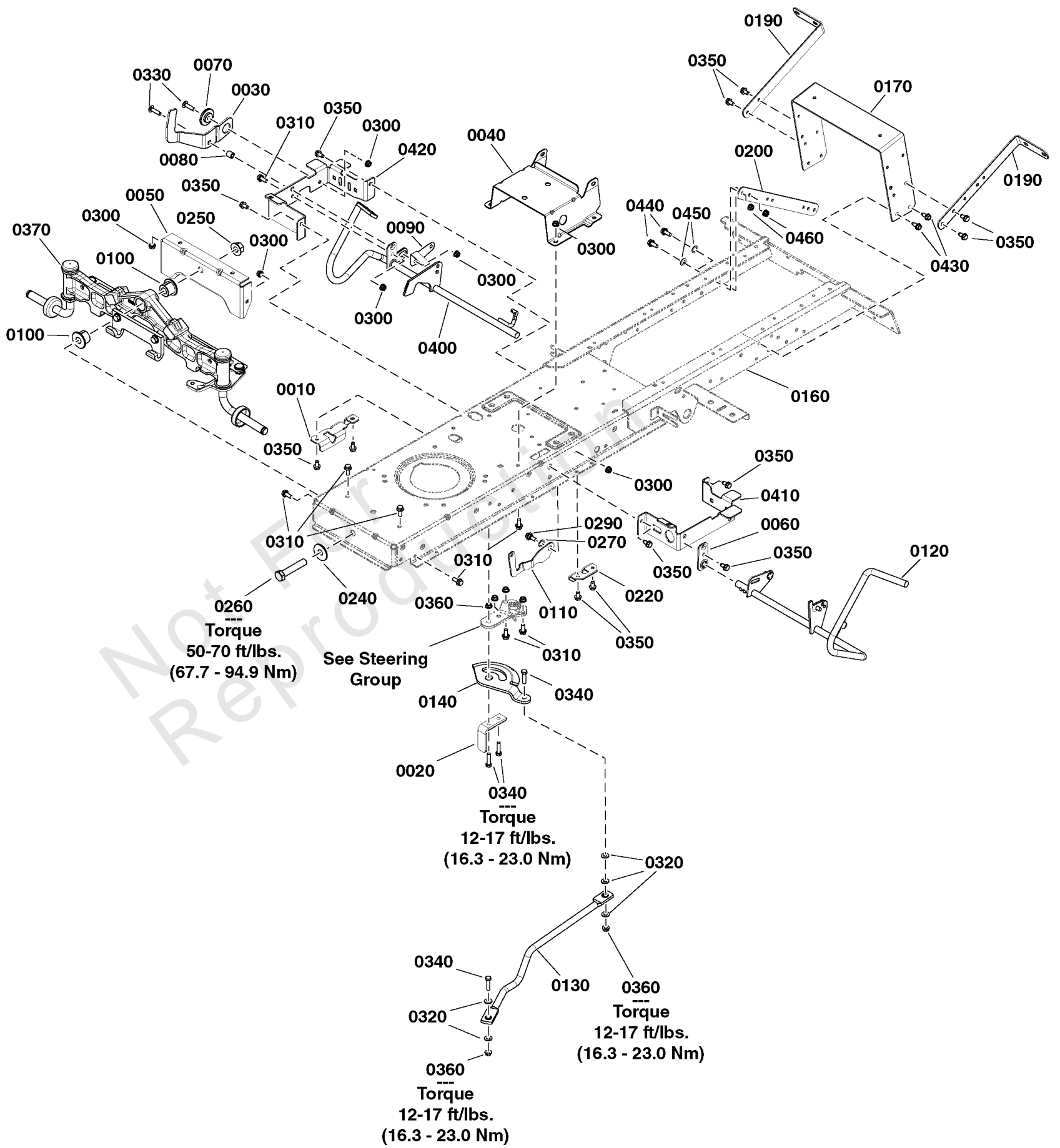

## Frame Group

REF NO	PART NO	QTY	DESCRIPTION
0010	84004842	1	BRACKET, Pedal Pivot
0020	84003023	1	UPSTOP
0030	1727246SM	1	PEDAL, Reverse
0040	1727282SM	1	SUPPORT, Battery
0050	1727902SM	1	PLATE, Axle Support
0060	1727911ASM	1	PLATE, Bearing
0070	1727935SM	1	SPACER-PIVOT 0.330ID
0080	1728024SM	1	SPACER, Foot Pedal
0090	1728025BMYP	1	ACTUATOR, RMO Switch
0100	1730186SM	2	BUSHING, Axle Pivot
0110	1761926CJYP	1	LATCH, PARKING BRAKE
0120	84003024	1	PEDAL ASSEMBLY
0130	1738051YP	1	LINK, Drag (with Bearing), 5/16
0140	1751110YP	1	GEAR, Steering
0160	-----	1	FRAME -(Not a serviceable part)
0170	84004843	1	SUPPORT, Seat
0190	84004844	1	SUPPORT, Upper Back Plate
0200	84003028	2	SUPPORT, Lower Back Plate
0220	84003029	1	BRACKET, Pivot
0240	1960035SM	1	WASHER-0.625(0.64IDX1
0250	84003031	1	NUT
0260	2860744SM	1	CAPSCREW, Hex Head, 5/8-11 x 3 1/4
0270	7014296YP	1	WASHER, Shim
0290	703851	1	BOLT, 5/16-18X1.15
0300	703409	10	NUT, 5/16-18, GR5
0310	703354	9	SCREW, 5/16-18
0320	1919326SM	5	WASHER, 5/16
0330	703446	2	BOLT, 5/16-18X1.25 G5
0340	703570	4	CAPSCREW, Hex Head, 5/16-18 x 1 1/4
0350	703949	13	SCREW, 5/16-18.625
0360	704067	6	NUT, HEX FLNG,5/16-18
0370	-----	1	Refer to: Front Axle Group
0400	84003032	1	PEDAL ASSEMBLY
0410	1761913AYP	1	SUPPORT, FOOTREST
0420	1759842BMYP	1	SUPPORT, Front Footrest, RH
0430	703228	4	SCREW, 5/16-18 X .75
0440	703408	4	CAPSCREW, 5/16-18
0450	703350	4	WASHER
0460	703115	4	NUT

# Front Axle Group

Note: Unless noted otherwise, use the standard torque specifications

Mfg. No: 2691705-01

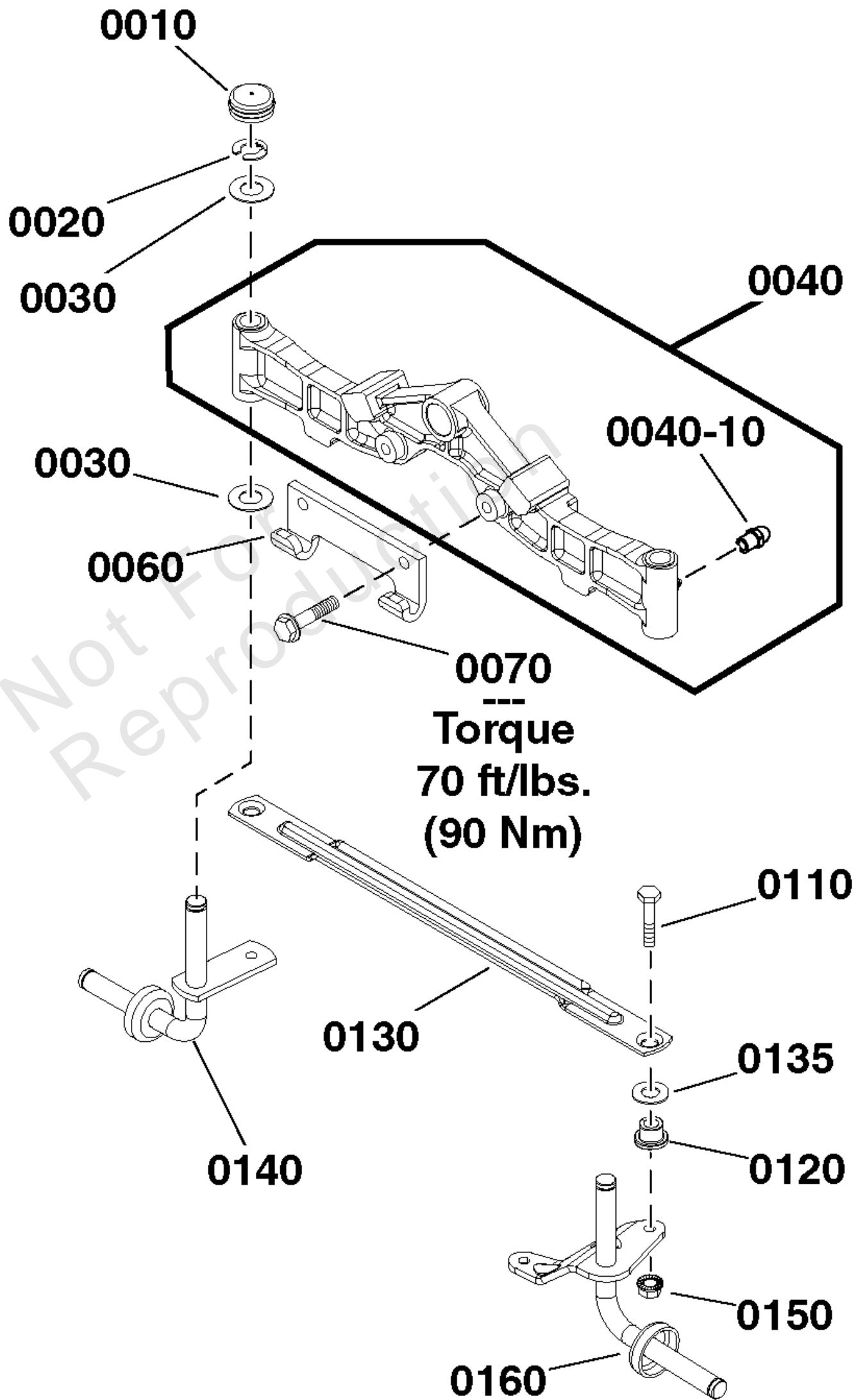

## Front Axle Group

REF NO	PART NO	QTY	DESCRIPTION
0010	1734135SM	2	CAP, Hub
0020	1611710SM	2	E-RING, 3/4
0030	2860183SM	4	WASHER, Flat, 3/4
0040	1756386YP	1	AXLE, Front
0040-10	1704314SM	2	LUBE FITTING, .250 DR -( Included with Ref. No. 0040 )
0060	1721918ASM	1	HOOK, Mower, Hitch
0070	1960652SM	2	SCREW, Hex Flange, Whiz Lock, 7/16-14 x 1-1/2
0110	1960032SM	2	SCREW, Hex Head, 3/8-16 x 1 1/4
0120	1731912SM	2	BUSHING, 3/8 ID x 5/8 OD x 1/2
0130	1751964YP	1	TIE ROD
0135	1960703SM	2	WASHER, 5/8
0140	1727872ASM	1	SPINDLE ASSEMBLY, R.H.
0150	703893	2	NUT, CNTR LCK, 3/8-16
0160	1751922YP	1	SPINDLE ASSEMBLY, L.H.

Not For Reproduction

# Hood, Grille & Dash Group

Note: Unless noted otherwise, use the standard torque specifications

Mfg. No: 2691705-01

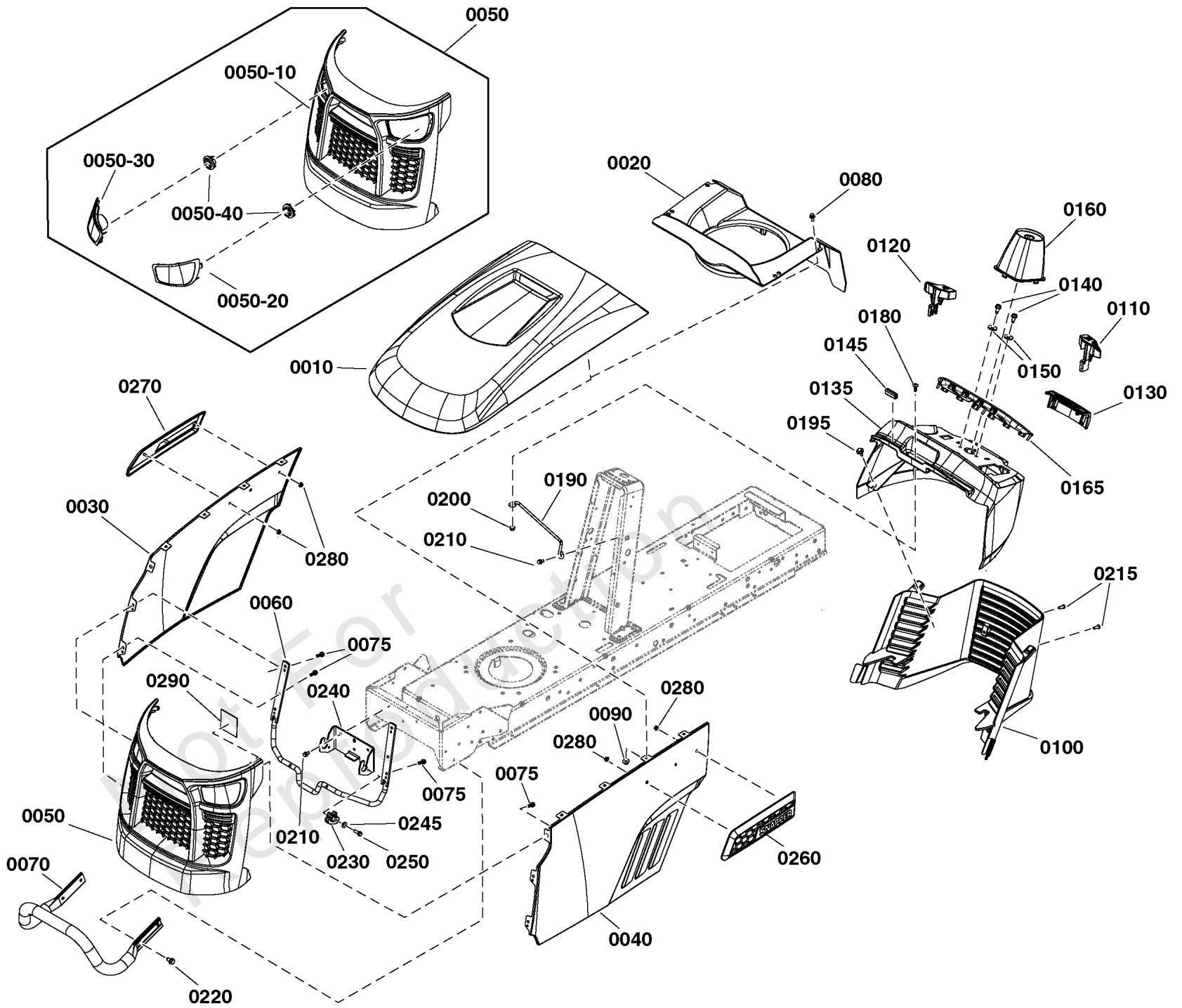

## Hood, Grille & Dash Group

REF NO	PART NO	QTY	DESCRIPTION
0010	1728031DSM	1	HOOD, with Scoop
0020	7102326YP	1	AIR DUCT, Plenum
0030	1761214DYP	1	PANEL, Side RH
0040	1761215DYP	1	PANEL, Side, LH
0050	1761263YP	1	GRILLE -(Incl. Ref. Nos. 0050-10, 0050-20, 0050-30 & 0050-40)
0050-10	1761175YP	1	GRILLE, Front -(Included with Ref. No. 0050)
0050-20	1761333YP	1	HEADLIGHT, LH -(Included with Ref. No. 0050)
0050-30	1761334YP	1	HEADLIGHT, RH -(Included with Ref. No. 0050)
0050-40	1760239YP	2	LED HEADLIGHT AND SOCKET ASSEMBLY -(Included with Ref. No. 0050)
0060	1761070YP	1	ROD, Hood Hinge
0070	1761254DYP	1	BUMPER, Tube
0075	706369	6	SCREW, Hex Washer Head, 1/4-10 x 3/4
0080	1960295SM	8	CAPSCREW, Hex Flange, Whiz Lock, 1/4-20 x 5/8
0090	703161	8	NUT
0100	1761508YP	1	LOWER DASH ASSEMBLY
0110	1761401YP	1	KNOB, Parking Brake
0120	1761402YP	1	KNOB, Cruise
0130	1761510YP	1	DECORATIVE TRIM
0135	1761253YP	1	DASH, Upper
0140	703228	2	SCREW, 5/16-18 X .75
0145	1761773YP	2	EDGING, Rubber
0150	703298	2	WASHER, 5/16
0160	1761399YP	1	COVER, Steering Shaft
0165	84002723	1	DASH BEZEL
0180	770135	1	SCREW
0190	1761481YP	1	ROD, Dash Support
0195	2860664SM	2	SCREW, HEX SEMS WSHR,
0200	703463	1	NUT, GR5, 1/4-20
0210	704130	4	SCREW, HEX, 1/4-20X.5
0215	1960556SM	2	SCREW, Pan Head Torx, Taptite, 1/4-20 x 3/4
0220	703985	4	SCREW, 5/16-18X.5
0230	1761068YP	2	CLIP, Hood Hinge
0240	1761212CJYP	1	BRACKET, Hood Hinge
0245	703332	2	WASHER
0250	703466	2	BOLT, GR5, 1/4X.0750
0260	1761342YP	1	BADGE, Snapper, LH
0270	1761343YP	1	BADGE, Snapper, RH
0280	189164GS	4	PALNUT, 3/16
0290	1761818YP	1	INSULATION, Thermal

# Lift Group

Note: Unless noted otherwise, use the standard torque specifications

Mfg. No: 2691705-01

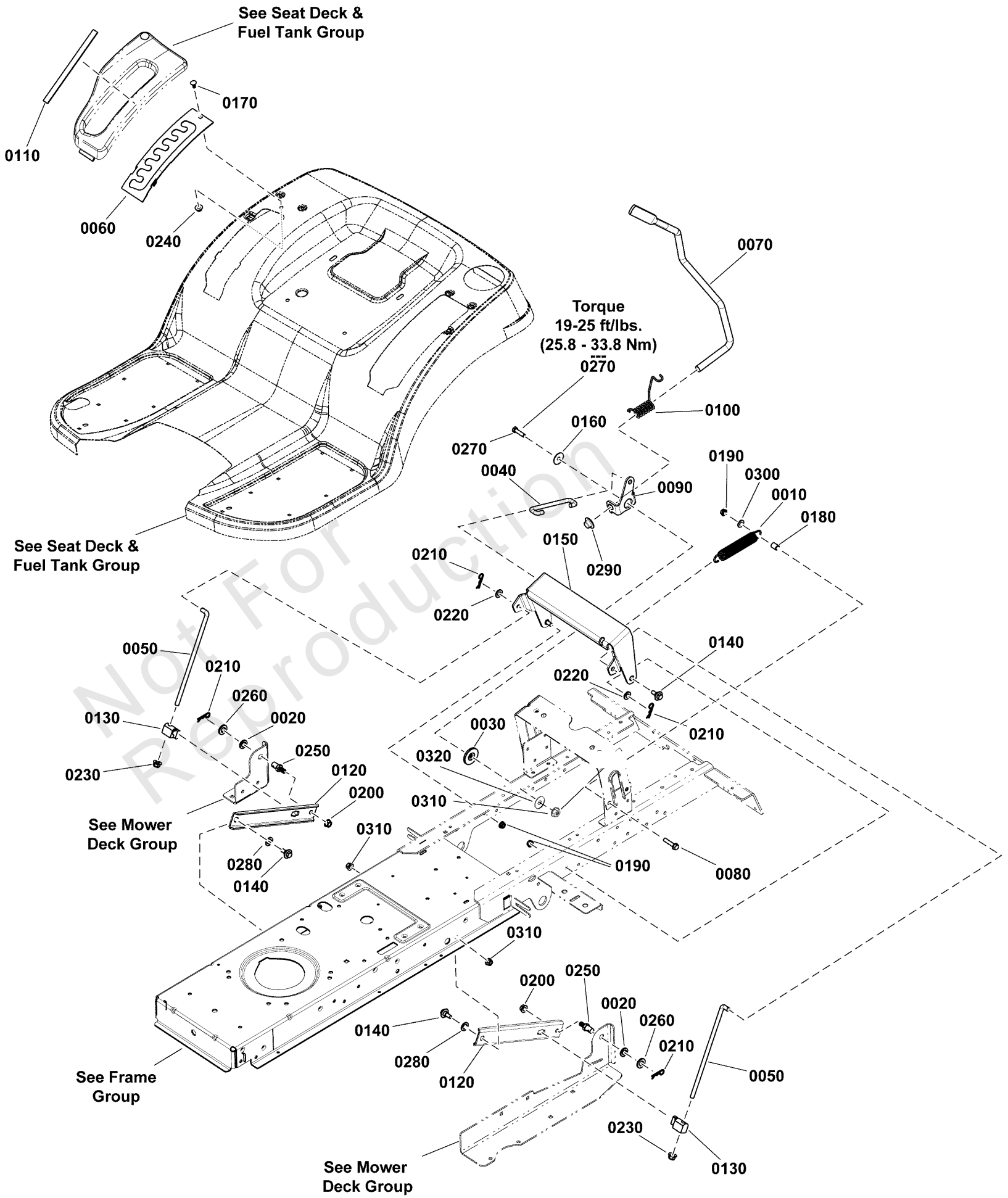



## Lift Group

REF NO	PART NO	QTY	DESCRIPTION
0010	1715435SM	1	SPRING, EXTENSION, 1.
0020	885382YP	2	WASHER, Rubber
0030	1727935SM	1	SPACER-PIVOT 0.330ID
0040	1727954SM	1	ROD, Lift .375 dia
0050	1727955SM	2	ROD, Lift, Lower, 3/8 x 10 Long
0060	1727985BMYP	1	QUADRANT, LIFT HEIGHT
0070	1728070SM	1	ROD, Lift Handle, 18-7/8"
0080	704318	1	SCREW, 5/16-18X1-1/2
0090	1728990ASM	1	CLEVIS, Lift
0100	1729652SM	1	SPRING, Torsion
0110	1730264SM	1	DECAL, Height Of Cut
0120	1731417BMYP	2	ARM, REAR LIFT ECOAT
0130	1731894SM	2	TRUNNION
0140	1732426SM	4	BOLT-SHLDR 5/16-18 0.
0150	84003052	1	BRACKET, Lifting
0160	1933468SM	1	WASHER, 5/16 x 1-1/4 OD
0170	1960252SM	1	BOLT-RD HD SH SQ NK 1
0180	1710703SM	1	SPACER, 3/8 x 1/2 x 5/8
0190	703409	2	NUT, 5/16-18, GR5
0200	703333	2	NUT, 3/8-16
0210	703300	4	PIN, 3/32 X 1.6
0220	703590	2	WASHER, FLAT, .406
0230	703158	2	NUT, Hex Flange, 3/8-16
0240	703161	1	NUT
0250	704054	2	PIN, 3/8-16
0260	703853	2	WASHER, 0.516IDX1OD
0270	84003606	1	SCREW
0280	703128	2	WASHER
0290	771009	1	PUSHNUT, 5/8
0300	1919326SM	1	WASHER, 5/16
0310	703115	4	NUT
0320	703298	1	WASHER, 5/16

# Seat Deck & Fuel Tank Group

Note: Unless noted otherwise, use the standard torque specifications

Mfg. No: 2691705-01

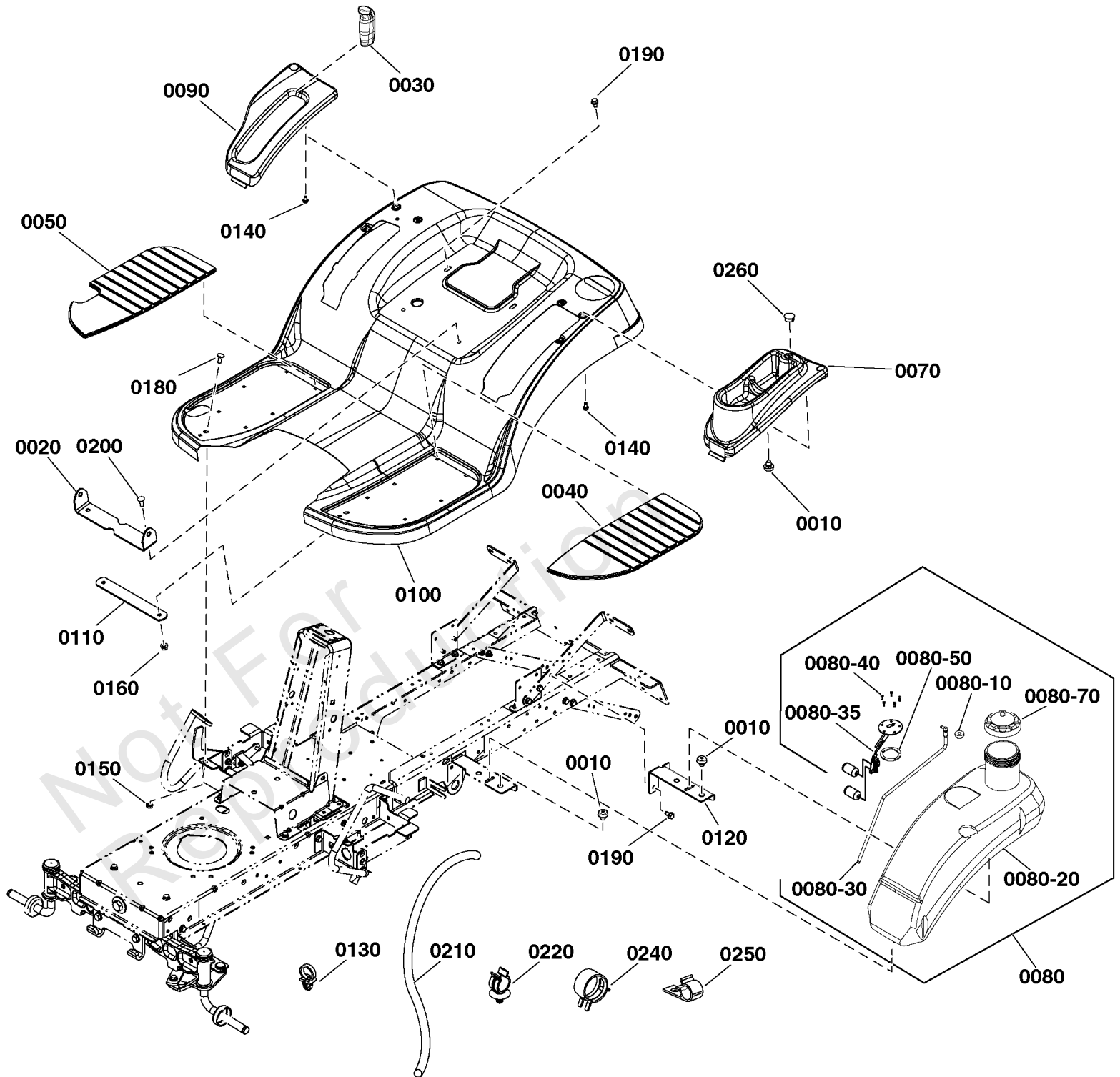

## Seat Deck & Fuel Tank Group

REF NO	PART NO	QTY	DESCRIPTION
0010	197546GS	5	MOUNT-VIBRATION
0020	885538AYP	1	PIVOT, Seat
0030	1722302SM	1	GRIP
0040	1728006SM	1	PAD, Footrest, L.H.
0050	1728007SM	1	PAD, Footrest, R.H.
0070	1758774YP	1	POD, LH
0080	1758414YP	1	FUEL TANK ASSEMBLY
0080-10	1654930SM	1	BUSHING, Fuel Tank
0080-20	-----		FUEL TANK -(Not Serviceable)
0080-30	1758506YP	1	TUBE, Fuel Pickup
0080-35	1758611YP	1	SENDER, Fuel
0080-40	2860665SM	5	SCREW, Pan Head, Torx, 10-32 x 1/2
0080-50	1758898YP	1	PLATE, Mounting, Fuel Sender
0080-70	5101651SM	1	CAP, FUEL, VENTED
0090	1739537YP	1	POD, R.H.
0100	1758849DYP	1	SEAT DECK, Red
0110	1759177CJYP	1	BRACKET, Support, Seat Pivot
0120	84004838	1	BRACKET, Fuel Tank, Rear
0130	1730268SM	1	CLIP, Hose, 1/2 Dia., Push In
0140	1960536SM	6	SCREW, HEX WSHR HD PL
0150	703409	2	NUT, 5/16-18, GR5
0160	703115	2	NUT
0180	703185	2	BOLT, Round Head, Short Square Neck
0190	703949	4	SCREW, 5/16-18.625
0200	704065	2	BOLT, 5/16-18X.875
0210	845503	1	LINE-FUEL
0220	84003041	3	CLIP, Hose
0240	791850	2	CLAMP, Hose
0250	84003042	1	CLIP, Hose, Screw Mount
0260	1732007SM	1	PLUG, Hole, 7/8 Dia.

# Seat Group

Note: Unless noted otherwise, use the standard torque specifications

Mfg. No: 2691705-01

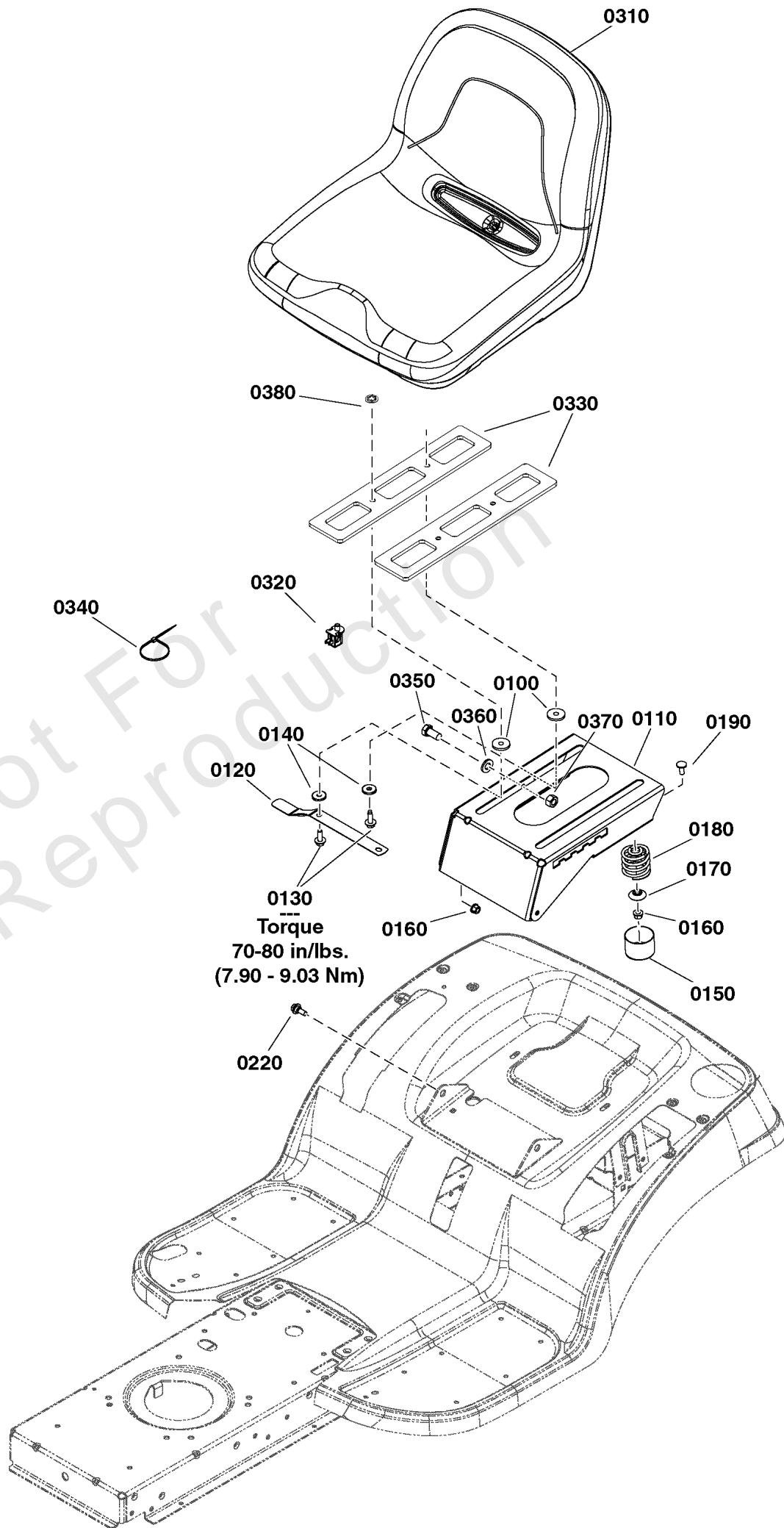

## Seat Group

REF NO	PART NO	QTY	DESCRIPTION
0100	1731300SM	4	SPACER, 5/16 ID x 1-1/4 OD x 5/16"
0110	1755767BMYP	1	SUPPORT, Seat
0120	1727268BMYP	1	LATCH, Seat
0130	1933689SM	4	SCREW, 5/16-18 x 1-1/2, Hex Flange, Whiz Lock
0140	703298	4	WASHER, 5/16
0150	1704724SM	2	COVER, Spring, 1-1/2"
0160	703115	4	NUT
0170	1709256SM	2	WASHER, Spring, 5/16 x 1 1/4
0180	1704728SM	2	SPRING, Compression, 2"
0190	703225	2	BOLT
0220	703851	2	BOLT, 5/16-18X1.15
0310	84003944	1	SEAT, 15"
0320	7023354YP	1	SWITCH, SEAT
0330	84003652	2	SPACER, Plate
0340	703586	1	TIE, SELF LOCKING
0350	1923114SM	1	CAPSCREW, Hex Head 1/2-13 x 1, Black
0360	703853	1	WASHER, 0.516IDX1OD
0370	703340	1	NUT,1/2-13,GR5,HEX,ZC
0380	703297	4	RETAINER, GR5, 5/16

# Steering Group

Note: Unless noted otherwise, use the standard torque specifications

Mfg. No: 2691705-01

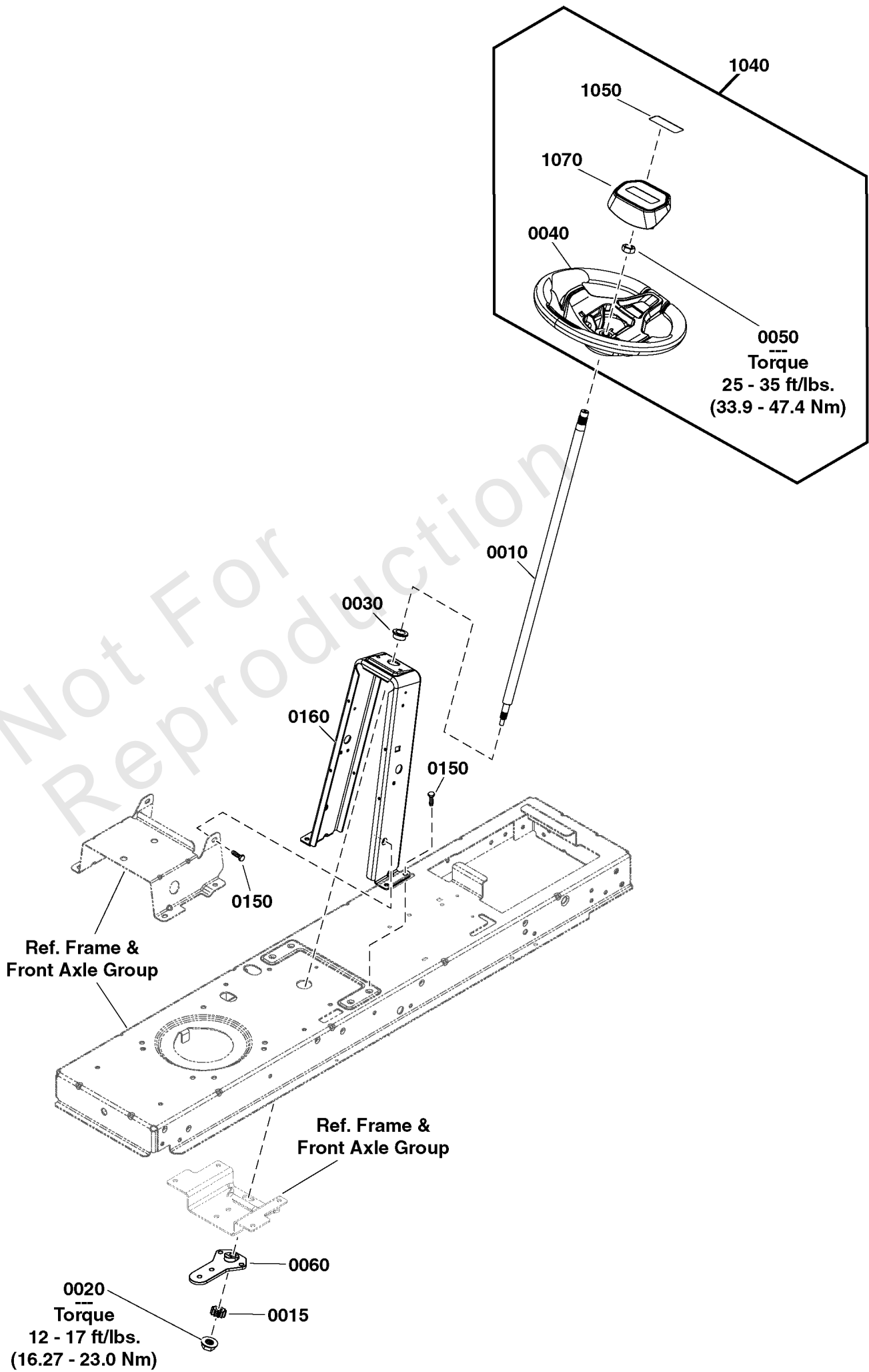

## Steering Group

REF NO	PART NO	QTY	DESCRIPTION
0010	1761012YP	1	SHAFT, Steering
0015	1761013YP	1	GEAR, Pinion
0020	703115	1	NUT
0030	1729665SM	1	BUSHING, Steering, 3/4 ID
1040	84001121	1	KIT, Steering Wheel, Snapper -( Incl. Ref. Nos. 0040, 0050, 1050 & 1070 )
0040	-----	1	STEERING WHEEL
0050	1960576SM	1	NUT, Hex Lock, ESNA Light, 5/8-18
1050	84002249	1	DECAL, Snapper Logo, 3.1" X .8"
1070	84002250	1	CAP, Steering Wheel
0060	1761010YP	1	SUPPORT, Steering
0150	703949	6	SCREW, 5/16-18.625
0160	1761498CJYP	1	TOWER, Steering

Not For Reproduction

# Transmission Group - Tuff Torq K46EC

Note: Unless noted otherwise, use the standard torque specifications

Mfg. No: 2691705-01

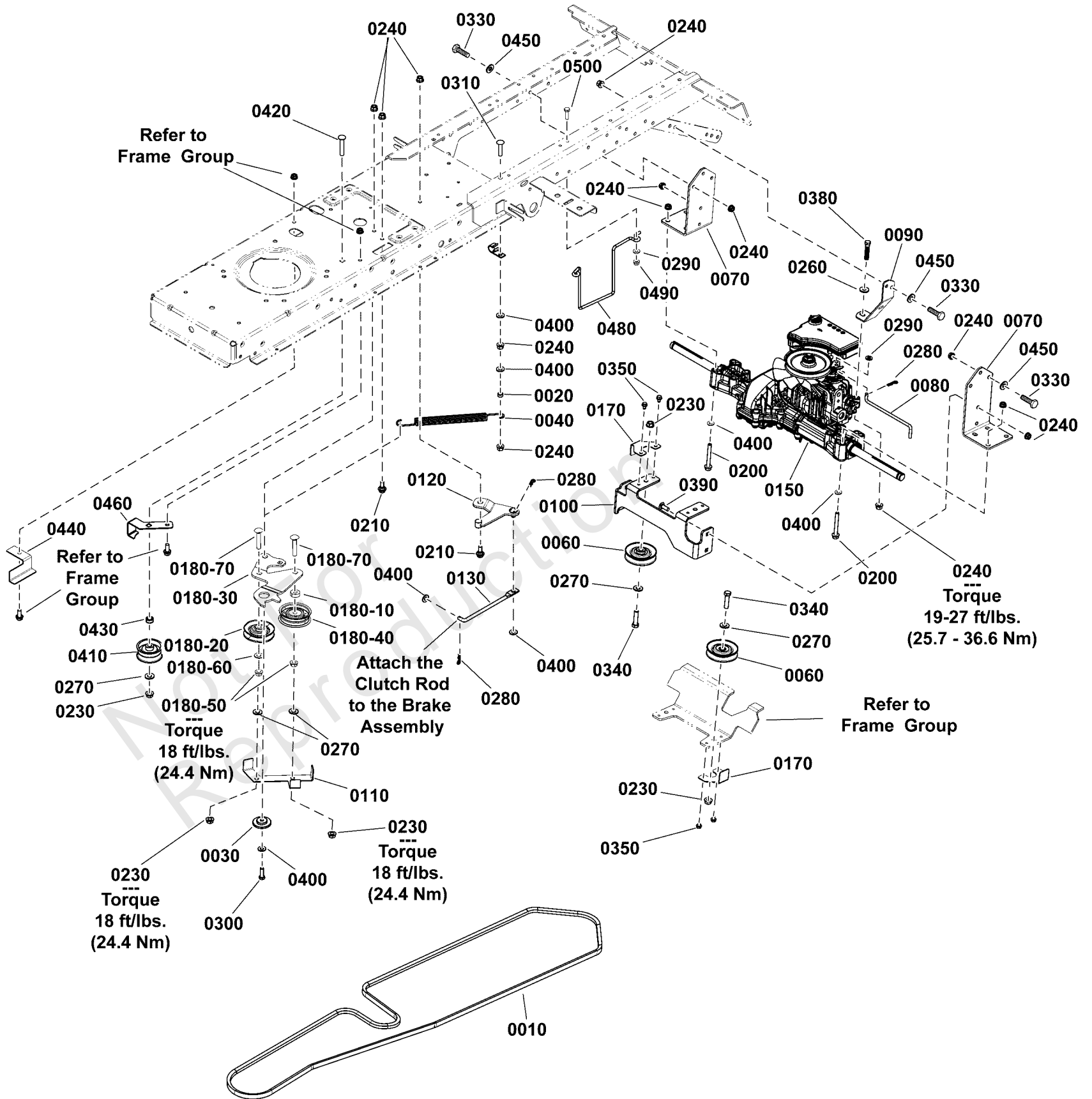



## Transmission Group - Tuff Torq K46EC

REF NO	PART NO	QTY	DESCRIPTION
0010	84001118	1	BELT, RDLT, 115.1
0020	5102463YP	1	SPACER, .33 X .50X.25
0030	1727935SM	1	SPACER-PIVOT 0.330ID
0040	84002611	1	SPRING, Extension
0060	1760012YP	4	PULLEY, Idler
0070	84002634	2	BRACKET, Transmission Mounting
0080	84002612	1	ROD, Transmission
0090	84002635	1	BRACKET, Transmission Mounting, Rear
0100	84002636	1	BRACKET, Transmission Pulley
0110	84002637	1	BRACKET, Belt Guide
0120	84002638	1	CLUTCH PIVOT ASSEMBLY
0130	84002639	1	CLUTCH ROD
0150	84002640	1	TRANSMISSION, Tuff Torq K46EC
0170	84002645	4	BELT GUIDE
0180-10	1667811SM	1	SPACER
0180-20	1760012YP	1	PULLEY, Idler
0180-30	84003365	1	BRACKET, Idler
0180-40	2154534SM	1	PULLEY ASSEMBLY IDLER
0180-50	703333	2	NUT, 3/8-16
0180-60	703878	1	WASHER, FLAT
0180-70	1960315SM	2	CARRIAGE BOLT, 3/8-16 x 2
0200	703869	8	CAPSCREW, 5/16-18X2.75
0210	703851	2	BOLT, 5/16-18X1.15
0230	703333	7	NUT, 3/8-16
0240	703115	26	NUT
0260	703118	1	WASHER, Flat, 7/8, GR5
0270	703878	7	WASHER, FLAT
0280	703430	3	PIN, 13X1.19
0290	703332	3	WASHER
0300	703570	1	CAPSCREW, Hex Head, 5/16-18 x 1 1/4
0310	703296	1	BOLT, 5/16-18X1.5
0330	703408	8	CAPSCREW, 5/16-18
0340	772248	4	KIT, IDLER TRACTION DRIVE
0350	703583	8	SCREW, 1/4-20X.375
0380	704288	1	SCREW
0390	704065	4	BOLT, 5/16-18X.875
0400	1919326SM	13	WASHER, 5/16
0410	1668477SM	1	PULLEY, Idler, 2.25" OD, .378 ID
0420	1960315SM	1	CARRIAGE BOLT, 3/8-16 x 2
0430	5044960SM	1	SPACER, .39 X 1.00 X
0440	84002648	1	GUIDE, Belt, Black
0450	703350	8	WASHER
0460	84003787	1	GUIDE, BELT
0480	84004428	1	GUIDE, BELT
0490	703463	2	NUT, GR5, 1/4-20
0500	703819	2	CAPSCREW, 1/4-20X0.875

# Transmission SERVICE PARTS - Tuff Torq K46EC (1761877)

Note: Unless noted otherwise, use the standard torque specifications

Mfg. No: 2691705-01

K46EC  
Ser. No. 0000001 - Current  
Rev. 5-08-18

ACTUAL PARTS  
MAY NOT APPEAR  
AS SHOWN

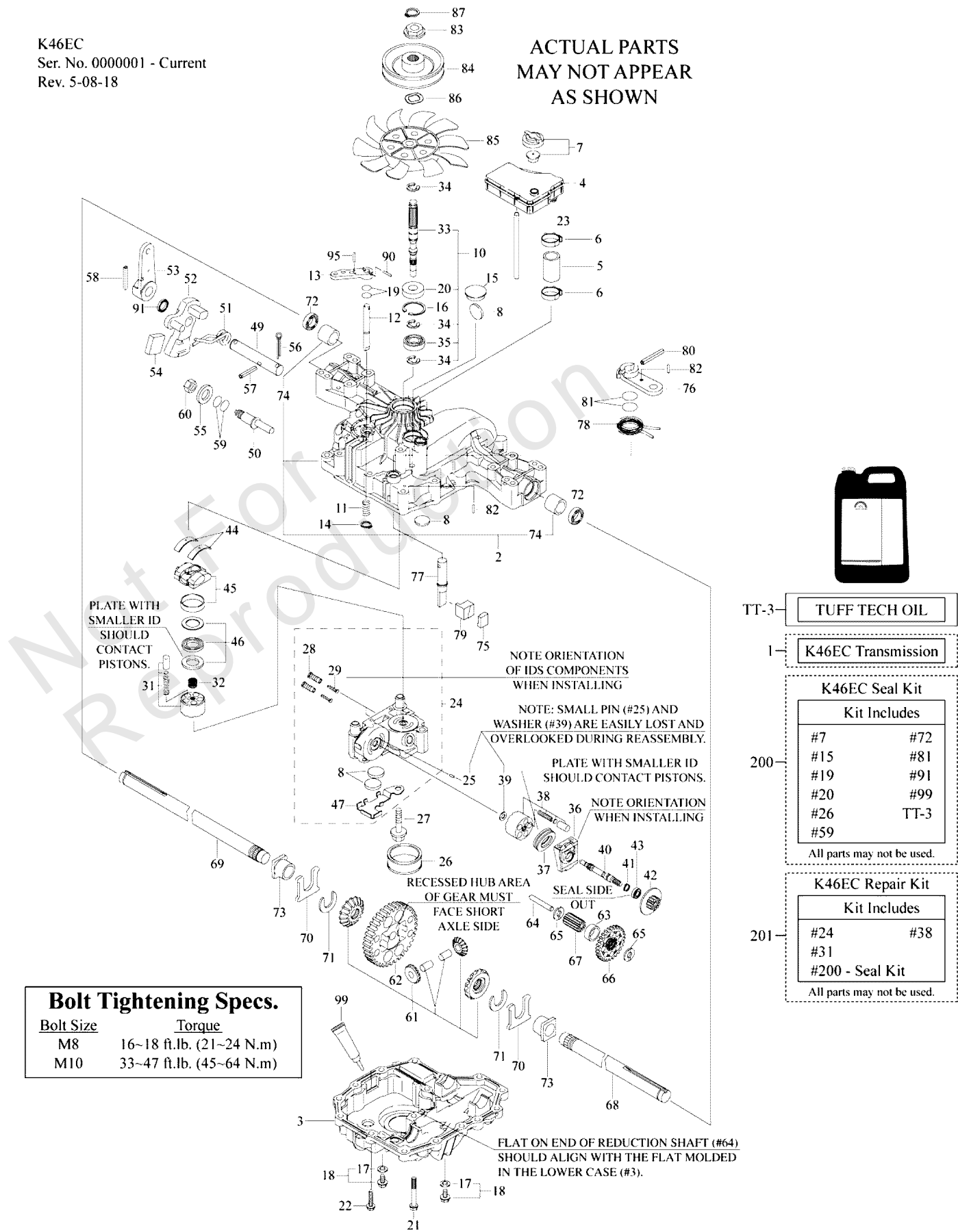

**Bolt Tightening Specs.**

Bolt Size	Torque
M8	16~18 ft.lb. (21~24 N.m)
M10	33~47 ft.lb. (45~64 N.m)



- TT-3 TUFF TECH OIL
- 1 K46EC Transmission
- K46EC Seal Kit
 

Kit Includes	
#7	#72
#15	#81
#19	#91
#20	#99
#26	TT-3
#59	

All parts may not be used.
- 201 K46EC Repair Kit
 

Kit Includes	
#24	#38
#31	
#200 - Seal Kit	

All parts may not be used.

## Transmission SERVICE PARTS - Tuff Torq K46EC (1761877)

REF NO	PART NO	QTY	DESCRIPTION
1	84002640	1	TRANSMISSION, Tuff Torq K46EC
2	-----	1	KIT, Upper Case
3	-----	1	LOWER CASE
4	-----	1	RESERVOIR TANK 310
5	-----	1	TUBE
6	-----	1	COBRA CLAMP
7	1718052	1	VENT VALVE 15
8	1724279	2	MAGNET
9	-----	1	* MAGNET HOLDER
10	-----	1	* KIT, Pump Shaft/Bearing
11	-----	1	* SPRING 25
12	1724281	1	BYPASS SHAFT A
13	1720418	1	LEVER, Bypass
14	1718061	1	RING, Snap, 10
15	1724282	1	SEALING CAP 30
16	1708650	1	RING, Snap, C 35
17	1724323	2	SEAL WASHER 8
18	-----	1	* KIT, Drain Bolt
19	1708691	2	O-RING, 1A P10A
20	1708651	14	SEAL TC 153507
21	-----	1	* SCREW, Tapping, 8 * 55
22	1707789	1	SCREW, Tapping, 8 * 30
23	-----	1	TANK SUPPORT
24	-----	1	* CENTER CASE K W/ 1.2 FILTER IDS KIT
25	1718070	3	PIN, 3 * 9.8
26	-----	2	* FILTER 105
27	1720805	2	BOLT, 10 * 75
28	-----	2	* IDS VALVE 1.2
29	-----	1	* IDS SPRING
30	-----	1	* IDS FILTER 300
31	-----	1	*KIT, Cylinder Block (Pump)
32	-----	3	* SPRING
33	1739892	1	PUMP SHAFT
34	1718076	1	E-RING 15
35	1708673	1	BEARING, 6202C3
36	1718077	1	MOTOR HOUSING
37	-----	1	* THRUST BEARING 51106
38	1718079	1	KIT, Cylinder Block
39	1718084	1	WASHER, 12 * 24 * 1
40	1724943	1	MOTOR SHAFT
41	1708672	1	RING, Snap, S15
42	1724944	1	BRAKE DISC/MOTOR GEAR (10T)
43	-----	1	* BEARING, 6202 RSR C3
44	1718089	1	THRUST METAL
45	-----	1	* SWASH PLATE CMP
46	1718086	1	THRUST BEARING K81105
47	-----	1	MAGNET HOLDER
49	-----	1	* CONTROL SHAFT

### Footnotes:

Note:\* See your local authorized dealership for parts and warranty or contact Tuff Torq at [www.tufftorqservices.com](http://www.tufftorqservices.com) (U.S. 1-866-572-3441 Int'l 01-423-585-1977)

# Transmission SERVICE PARTS - Tuff Torq K46EC (1761877)

Note: Unless noted otherwise, use the standard torque specifications

Mfg. No: 2691705-01

K46EC  
Ser. No. 0000001 - Current  
Rev. 5-08-18

ACTUAL PARTS  
MAY NOT APPEAR  
AS SHOWN

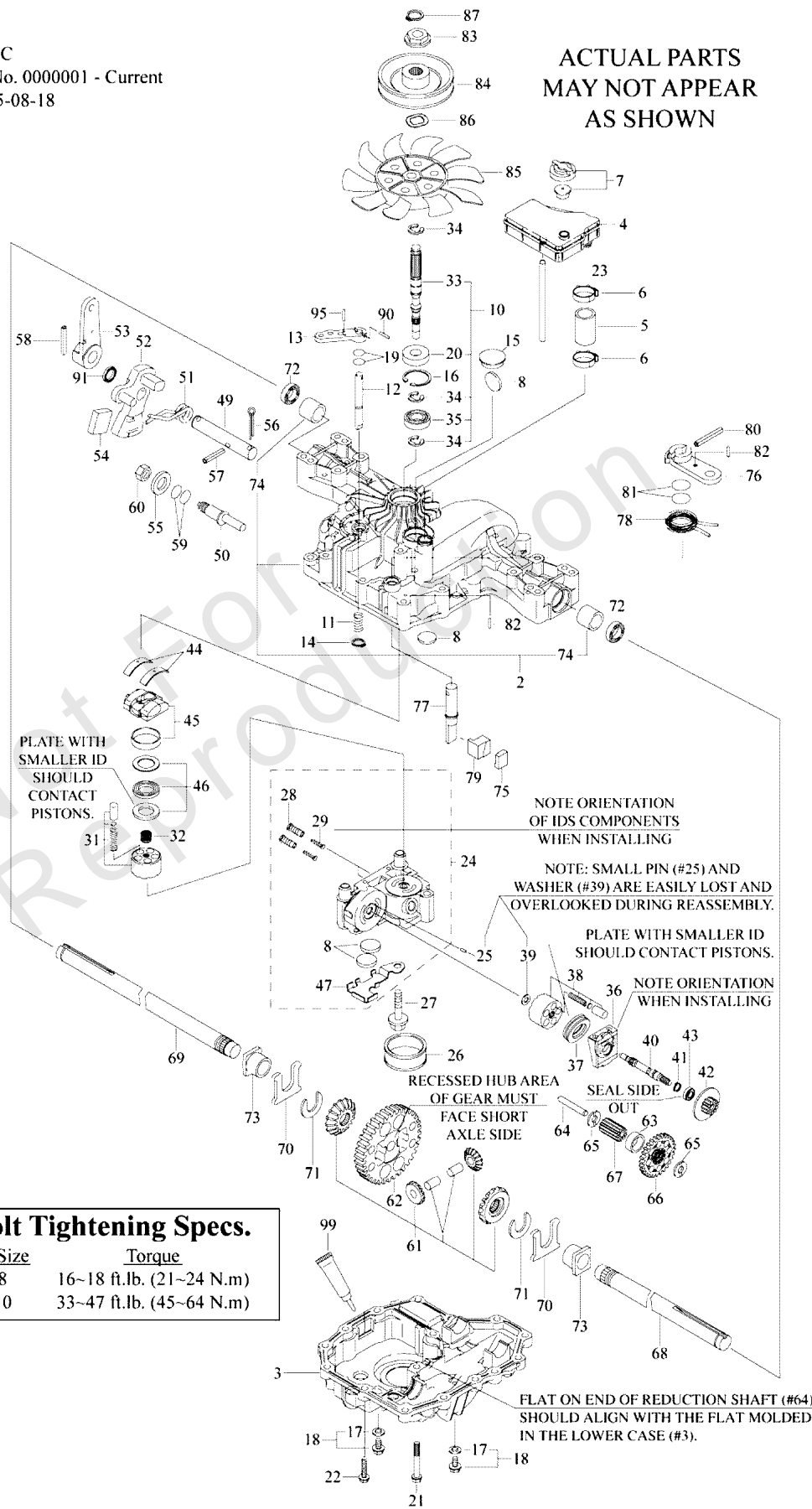

Bolt Tightening Specs.	
Bolt Size	Torque
M8	16~18 ft.lb. (21~24 N.m)
M10	33~47 ft.lb. (45~64 N.m)



- TT-3 TUFF TECH OIL
- 1 K46EC Transmission
- K46EC Seal Kit
 

Kit Includes	
#7	#72
#15	#81
#19	#91
#20	#99
#26	TT-3
#59	

All parts may not be used.
- K46EC Repair Kit
 

Kit Includes	
#24	#38
#31	
#200 - Seal Kit	

All parts may not be used.

## Transmission SERVICE PARTS - Tuff Torq K46EC (1761877)

REF NO	PART NO	QTY	DESCRIPTION
50	-----	1	* FULCRUM
51	-----	1	* SPRING, Torsion
52	-----	1	* CONTROL ARM A
53	1724347	1	CONTROL LEVER C
54	-----	1	* JERKY PLATE
55	1708689	1	WASHER, 12
56	1724349	1	COTTER PIN, 1/8 * 3/4
57	1724296	1	SPRING PIN 6 * 36
58	1718100	1	ROLL PIN 6 * 40
59	1707879	1	O-RING 1A P14
60	1708692	1	NUT 12
61	-----	1	* KIT, Diff Gear
62	-----	2	* FINAL GEAR (54T)
63	-----	1	* FINAL PINION COLLAR
64	-----	1	* REDUCTION SHAFT
65	1724948	1	WASHER, 12 * 32 * 3.2
66	1724949	1	REDUCTION GEAR (38T)
67	-----	2	* FINAL PINION GEAR (10T)
68	1724303	2	AXLE SHAFT, Left
69	1724304	2	AXLE SHAFT, Right
70	1718112	2	THRUST WASHER
71	1718113	1	RING 17
72	1718111	1	SEAL 19 * 32 * 8 -( For this part only contact B&S Tech support )
73	1718110	1	BUSHING, 19 * 25
75	1724305	1	BRAKE SHOE
76	1724306	1	BRAKE LEVER
77	-----	1	* BRAKE SHAFT
78	-----	1	* SPRING, Brake Return
79	1724309	1	BRAKE ACTUATOR
80	1724310	1	SPRING PIN 5 * 32
81	1708690	1	O-RING 1A P12
82	1724311	1	SPRING PIN 4 * 16
83	-----	1	SPLINE COLLAR
84	1732918	1	PULLEY D
85	1724314	1	FAN, White
86	1724315	1	WASHER, Wave
87	1724316	1	RING, Snap
90	-----	1	* SPRING PIN 3.0A * 20
91	1724318	1	OIL SEAL 16 * 22 * .03
95	-----	1	* SPRING PIN 3.0A * 16
99	-----	1	SEALANT
200	1727541	1	* K46 & T40 SEAL KIT (ALL MODELS)
201	-----	1	* REPAIR KIT K46

### Footnotes:

Note:\* See your local authorized dealership for parts and warranty or contact Tuff Torq at [www.tufftorqservices.com](http://www.tufftorqservices.com) (U.S. 1-866-572-3441 Int'l 01-423-585-1977)

# Wheels & Tires

Note: Unless noted otherwise, use the standard torque specifications

Mfg. No: 2691705-01

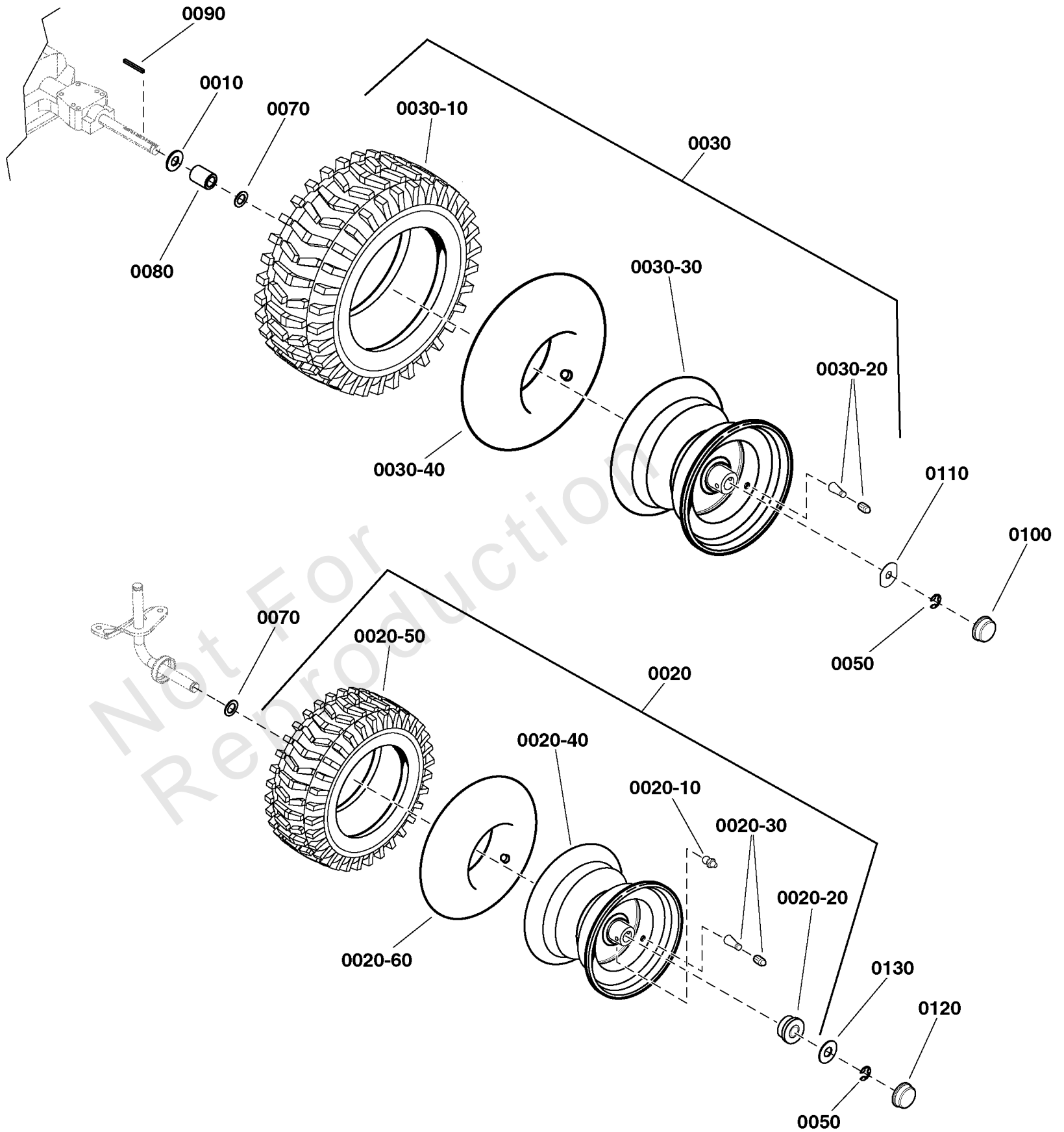

## Wheels & Tires

REF NO	PART NO	QTY	DESCRIPTION
0010	2860202SM	2	WASHER, 3/4 x 1-5/8 OD x 1/8 Thick
0020	1761503YP	2	WHEEL AND TIRE ASSEMBLY, Front, 15 x 6-6
0020-10	84003425	1	ZERK, Grease Fitting
0020-20	84003424	1	BEARING, Ball
0020-30	2172353SM	1	VALVE STEM & CAP
0020-40	-----	1	WHEEL, Front, 6" -(Refer to Note: *)
0020-50	7101556YP	1	TIRE, 15 x 6 2 Ply K358
0020-60	1664090SM	1	TUBE, Tire, Front
0030	7101569YP	2	WHEEL & TIRE ASSEMBLY, 22 X 9.5-12
0030-10	7101568YP	1	TIRE, 22 x 9.50-12, 2 Ply K358
0030-20	2172353SM	1	VALVE STEM & CAP
0030-30	-----	1	RIM, 12x x7 Int W/3 5 Lg Hub Silver -(Refer to Note: *)
0030-40	2173477SM	1	TUBE
0050	2827794SM	4	KLIPRING, .75 Dia Shaft
0070	1960528SM	4	WASHER, 49/64" I.D. x 1-1/4" O.D.
0080	84002985	2	SPACER, 0.77 ID x 1-1/4 OD x 2.44
0090	021553MA	1	KEY, Square, 3/16
0100	1722676SM	2	HUB CAP
0110	1722717SM	2	WASHER, 2-1/2
0120	1722675SM	2	CAP, Hub, 1-1/2 ID Gray Poly 1.3 HI
0130	1960160SM	2	WASHER, 0.750 ID x 1.60 OD x .05 Thick

Not For Reproduction

### Footnotes:

Note\* Not a serviceable part, service wheel complete

# Hardware Identification & Torque Specifications

Torque Specification Chart								
FOR STANDARD METRIC MACHINE HARDWARE (Tolerance ± 20%)								
Property Class	5.6		8.8		10.9		12.9	
	Class 5.6		Class 8.8		Class 10.9		Class 12.9	
Size Of Hardware	in/lbs	Nm.	in/lbs	Nm.	in/lbs	Nm.	in/lbs	Nm.
	ft/lbs		ft/lbs		ft/lbs		ft/lbs	
M3	5.88	.56	13.44	1.28	19.2	1.80	22.92	2.15
M4	13.44	1.28	30.72	2.90	43.44	4.10	52.56	4.95
M5	26.4	2.50	60.96	5.75	5.97	8.10	7.15	9.7
M6	44.64	4.3	7.3	9.9	10.3	14	12.1	16.5
M7	5.2	7.1	12.1	16.5	16.9	23	19.9	27
M8	7.7	10.5	17.7	24	25	34	29	40
M10	15	21	35	48	50	67	59	81
M12	26	36	61	83	86.2	117	103	140
M14	42	58	101	132	136	185	162	220
M16	64	88	147	200	210	285	250	340
M18	89	121	202	275	287	390	346	470
M20	126	171	290	390	405	550	486	660
M22	169	230	390	530	559	745	656	890
M24	217	295	497	375	708	960	840	1140
M27	320	435	733	995	1032	1400	1239	1680
M30	435	590	995	1350	1401	1900	1681	2280
M33	590	800	1349	1830	1902	2580	2278	3090
M36	759	1030	1740	2360	2441	3310	2935	3980
M39	988	1340	2249	3050	3163	4290	3798	5150

Torque Specification Chart						
FOR STANDARD MACHINE HARDWARE (Tolerance ± 20%)						
Hardware Grade	No Marks		SAE Grade 5		SAE Grade 8	
	SAE Grade 2		SAE Grade 5		SAE Grade 8	
Size Of Hardware	in/lbs	Nm.	in/lbs	Nm.	in/lbs	Nm.
	ft/lbs		ft/lbs		ft/lbs	
8-32	19	2.1	30	3.4	41	4.6
8-36	20	2.3	31	3.5	43	4.9
10-24	27	3.1	43	4.9	60	6.8
10-32	31	3.5	49	5.5	68	7.7
1/4-20	66	7.6	8	10.9	12	16.3
1/4-28	76	8.6	10	13.6	14	19.0
5/16-18	11	15.0	17	23.1	25	34.0
5/16-24	12	16.3	19	25.8	29	34.0
3/8-16	20	27.2	30	40.8	45	61.2
3/8-24	23	31.3	35	47.6	50	68.0
7/16-14	30	40.8	50	68.0	70	95.2
7/16-20	35	47.6	55	74.8	80	108.8
1/2-13	50	68.0	75	102.0	110	149.6
1/2-20	55	74.8	90	122.4	120	163.2
9/16-12	65	88.4	110	149.6	150	204.0
9/16-18	75	102.0	120	163.2	170	231.2
5/8-11	90	122.4	150	204.0	220	299.2
5/8-18	100	136	180	244.8	240	326.4
3/4-10	160	217.6	260	353.6	386	525.0
3/4-16	180	244.8	300	408.0	420	571.2
7/8-9	140	190.4	400	544.0	600	816.0
7/8-14	155	210.8	440	598.4	660	897.6
1-8	220	299.2	580	788.8	900	1,244.0
1-12	240	326.4	640	870.4	1,000	1,360.0

The guides and ruler furnished below are designed to help you select the appropriate hardware.



Nut, M8

Thread Diameter (mm)

Inside Diameter (in)      Threads per inch

Nut, 1/2-16



Screw, M8- 1.25 x 25

Thread Diameter (mm)      Distance between threads (mm)      Body Length (mm)

Body Diameter      Threads per inch      Body Length (in)

Screw, 1/2- 16 x 2



## Standard Hardware Sizing

When a washer or nut is identified as 1/2" (M8), this is the *Nominal size*, meaning the *inside diameter* is 1/2 inch (8mm metric thread diameter); if a second number is present it represents the *threads per inch* (distance between threads).

When bolt or capscrew is identified as 1/2 - 16 x 2" (M8 - 1.25 x 50), this means the *Nominal size*, or body diameter is 1/2 inch (8mm metric thread diameter), the second number, 16, represents the *threads per inch*, (*distance between threads*). The final number is the body length of the bolt or screw, 2 inches (50mm).

## NOTES

- These torque values are to be used for all hardware excluding: locknuts, self-tapping screws, thread forming screws, sheet metal screws and socket head setscrews.
- Recommended seating torque values for locknuts:
  - for prevailing torque locknuts - use 65% of grade 5 torques.
  - for flange whizlock nuts and screws - use 135% of grade 5 torques.
- Unless otherwise noted on assembly drawings, all torque values must meet this specification.

## Common Hardware Types

Hex Head Capscrew



Washer



Carriage Bolt



Hex Nut

## Wrench & Fastener Size Guide

1/4" Bolt or Nut Wrench—7/16"	5/16" Bolt or Nut Wrench—1/2"	3/8" Bolt or Nut Wrench—9/16"	7/16" Bolt or Nut Wrench (Bolt)—5/8" Wrench (Nut)—11/16"	1/2" Bolt or Nut Wrench—3/4"
M6 Bolt or Nut Wrench—10mm	M8 Bolt or Nut Wrench—13mm	M10 Bolt or Nut Wrench—17mm	M12 Bolt or Nut Wrench—19mm	M14 Bolt or Nut Wrench—22mm



